

**CONTACTS**

1. OWNER/SUBDIVIDER: DENOVA HOMES  
1500 WILLOW PASS COURT  
CONCORD, CA 94520  
PHONE: (925) 685-0110  
CONTACT: ALEC TAPPIN
2. CIVIL ENGINEER: CARLSON, BARBEE & GIBSON, INC.  
2633 CAMINO RAMON, SUITE 350  
SAN RAMON, CA 94583  
PHONE: (925) 866-0322  
JASON NERI, PE

**ABBREVIATIONS**

- BD BOUNDARY  
CB CATCH BASIN  
CL CENTERLINE  
EVAE EMERGENCY VEHICLE ACCESS EASEMENT  
EX EXISTING  
FI FIELD INLET  
L/S LANDSCAPE  
MIN MINIMUM  
MAX MAXIMUM  
PUE PUBLIC UTILITY EASEMENT  
P PROPERTY LINE  
R RADIUS  
R/W RIGHT-OF-WAY  
SDMH STORM DRAIN MANHOLE  
SSMH SANITARY SEWER MANHOLE  
S/W SIDEWALK  
TYP TYPICAL

**GENERAL NOTES**

- ASSESSORS PARCEL NO: 032-370-033 (PORTION)
- SITE AREA: 12.34± ACRES
- DWELLING UNITS: 106 UNITS
- DENSITY: 106 DWELLING UNITS / 12.34 AC = 8.6 DU/AC
- EXISTING ZONING: P-1 PLANNED UNIT DISTRICT
- PROPOSED ZONING: PLANNED DEVELOPMENT
- EXISTING USE: VACANT
- PROPOSED USE: SINGLE FAMILY RESIDENTIAL
- BASIS OF BEARING: THE BASIS OF BEARINGS FOR THIS MAP IS DETERMINED BY FOUND MONUMENTS SHOWN HEREON; THE BEARING BEING NORTH 01°02'26" EAST PER SUBDIVISION 7562 (462 M 46). THE BEARINGS SHOWN HEREON ARE BASED ON THE CALIFORNIA COORDINATE SYSTEM ZONE III (CCS 27).
- BENCHMARK: DATUM = CCC MONUMENT #3280, 4" BRASS DISC LOCATED AT THE INTERSECTION OF CYPRESS ROAD AND BETHEL ISLAND ROAD. ELEVATION ESTIMATE BY 1987 USGS RESURVEY OF BETHEL ISLAND AND VICINITY FOR DETERMINATION OF BENCHMARK ELEVATIONS. ELEVATION: -1.193 FEET (NGVD 29).
- FLOOD ZONE: ZONE AE AND X  
REFER TO FLOOD INSURANCE RATE MAPS 06013C0170F & 06013C03601 (JUNE 16, 2009)  
NOTE: A LETTER OF MAP REVISION (LOR), REMOVING THE AREA FROM THE SPECIAL FLOOD HAZARD AREA, WILL BE PROCESSED WITH FEMA PRIOR TO OCCUPANCY.
- WATER: DIABLO WATER DISTRICT (DWD)  
CITY OF OAKLEY
- STORM: IRONHOUSE SANITARY DISTRICT (ISD)
- SANITARY SEWER: PACIFIC GAS & ELECTRIC (PG&E)
- GAS & ELECTRIC: AT&T
- TELEPHONE: COMCAST
- CABLE TV: CCC FIRE PROTECTION DISTRICT
- FIRE: LEVEE OWNERSHIP AND MAINTENANCE SUBJECT TO THE CITY OF OAKLEY AND RECLAMATION DISTRICT 799.
- LEVEE: THIS PROJECT MAY BE PHASED. MULTIPLE GRADING PLANS AND FINAL MAPS MAY BE FILED ON THE LANDS SHOWN ON THIS VESTING TENTATIVE MAP IN ACCORDANCE WITH ARTICLE 4, SECTION 66456.1 OF THE SUBDIVISION MAP ACT.
- PHASING: THIS PROJECT MAY BE PHASED. MULTIPLE FINAL MAPS MAY BE FILED UPON APPROVAL OF THE VESTING TENTATIVE SUBDIVISION MAP.
- GRADING: ALL DIMENSIONS ARE PRELIMINARY AND SUBJECT TO THE FINAL CONSTRUCTION DOCUMENTS.
- DIMENSIONS:

**LEGEND**

EXISTING	PROPOSED	DESCRIPTION
---	---	PROJECT BOUNDARY
---	---	RIGHT OF WAY
---	---	LOT LINE
---	---	FACE OF CURB
---	---	EASEMENT LINE
---	---	LOT NUMBER
---	---	LOT DIMENSION
---	581	
---	50'	

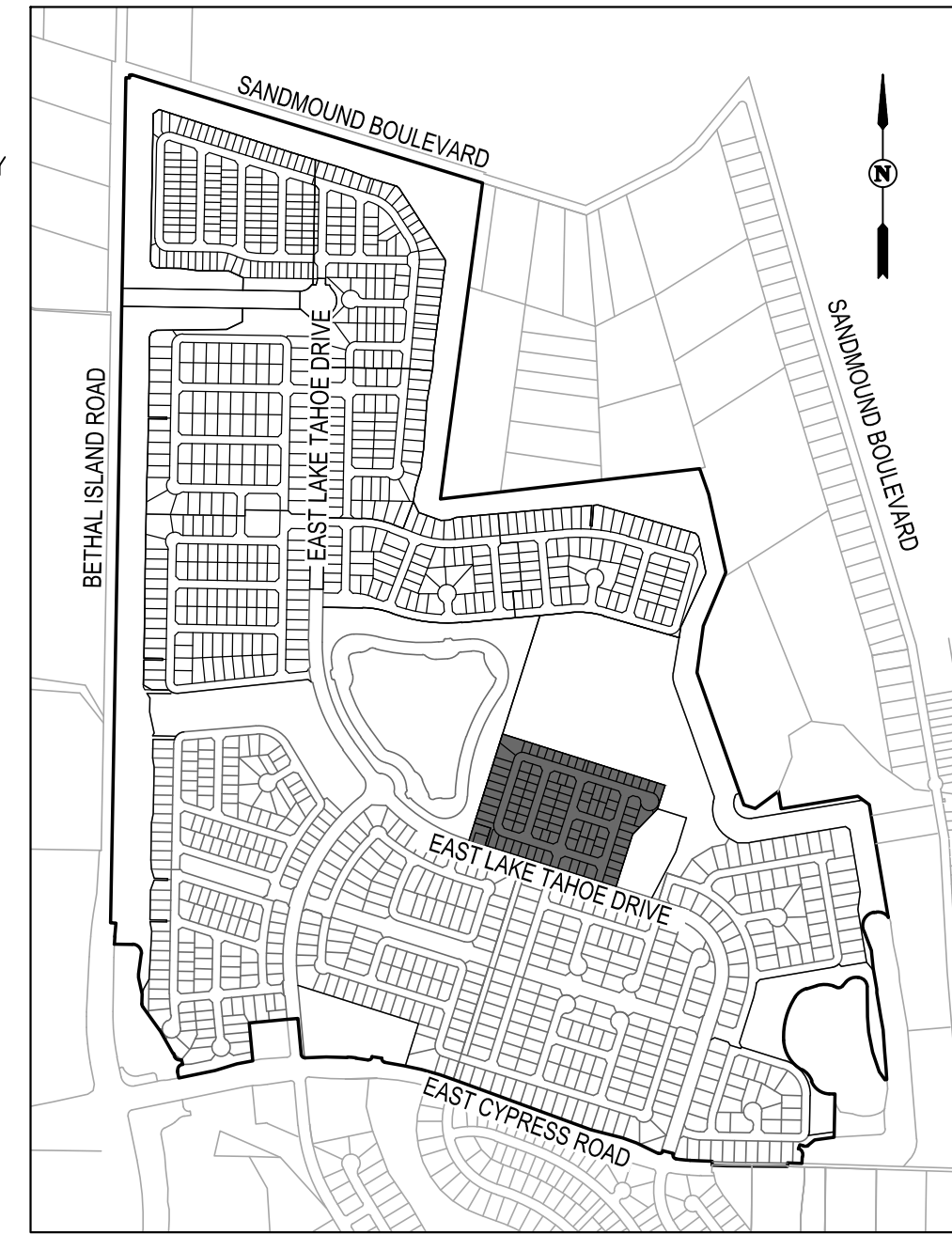

VICINITY MAP  
NOT TO SCALE

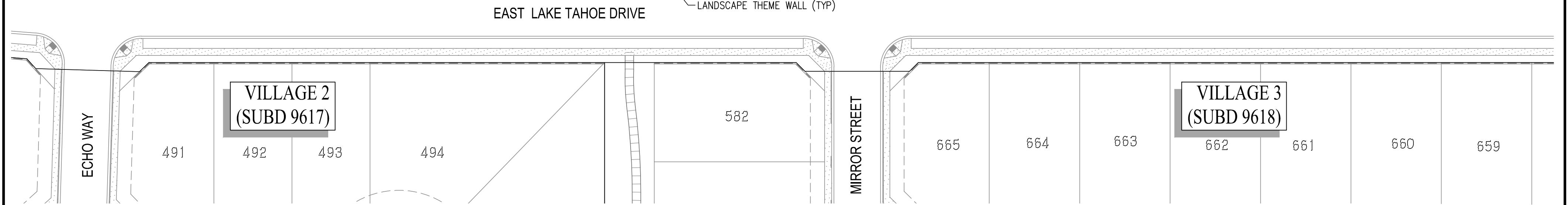

**SUBDIVISION 9660 - VILLAGE 18  
SUMMER LAKE NORTH  
VESTING TENTATIVE MAP**

CITY OF OAKLEY CONTRA COSTA COUNTY CALIFORNIA  
SCALE: 1"=50' DATE: JUNE 30, 2023

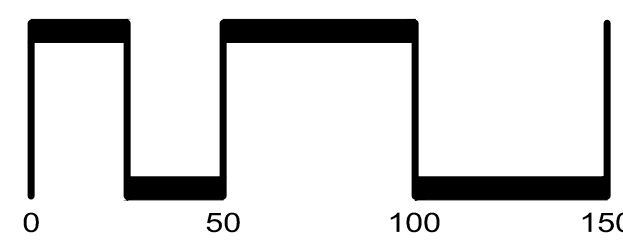
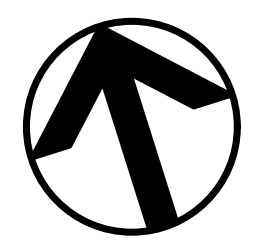

SAN RAMON • (925) 866-0322  
ROSEVILLE • (916) 788-4456  
WWW.CBANDG.COM

SHEET NO.  
**TM-1**  
OF 3 SHEETS

G:\1282-18\CAD\TM1\01.DWG

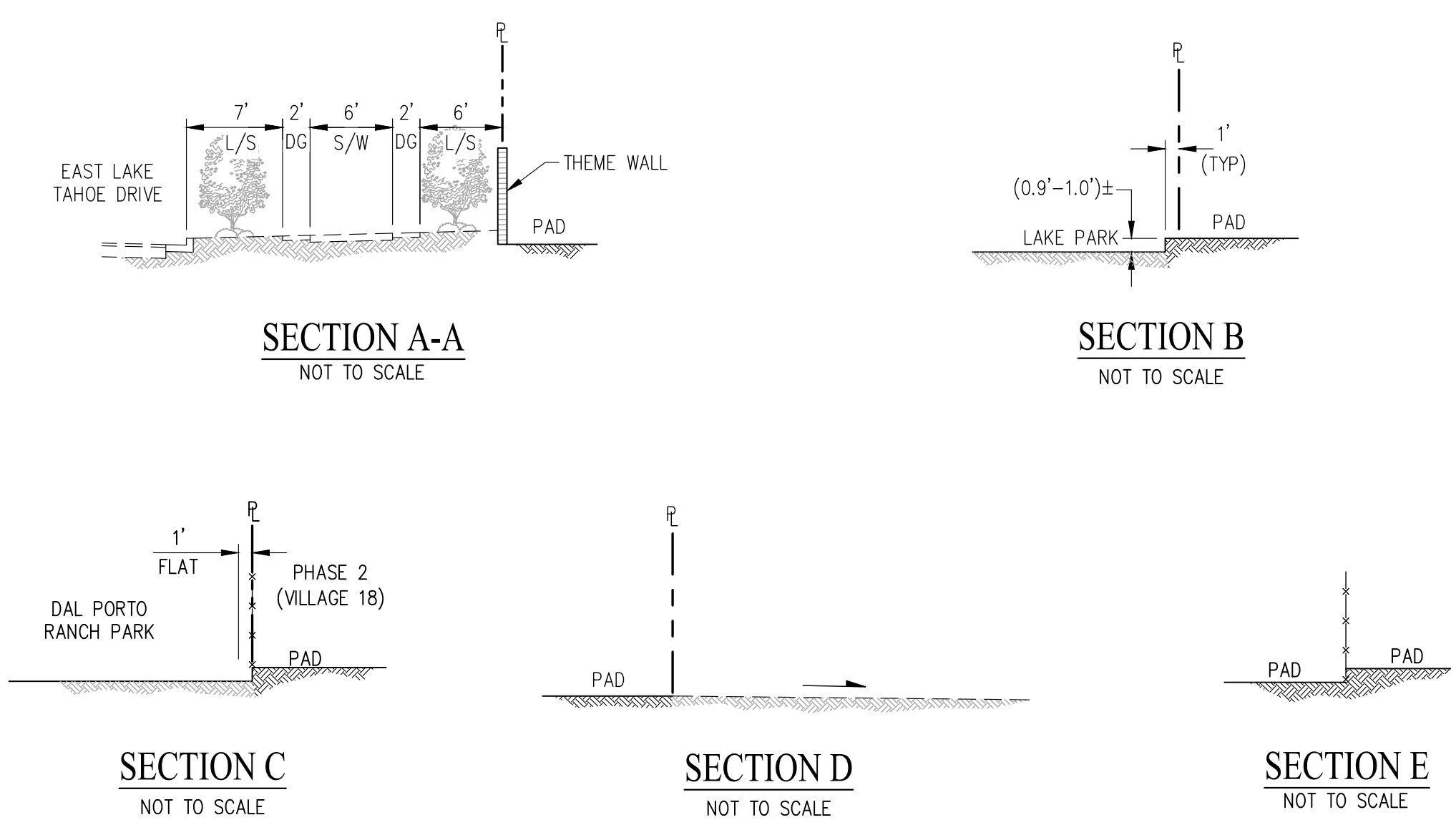
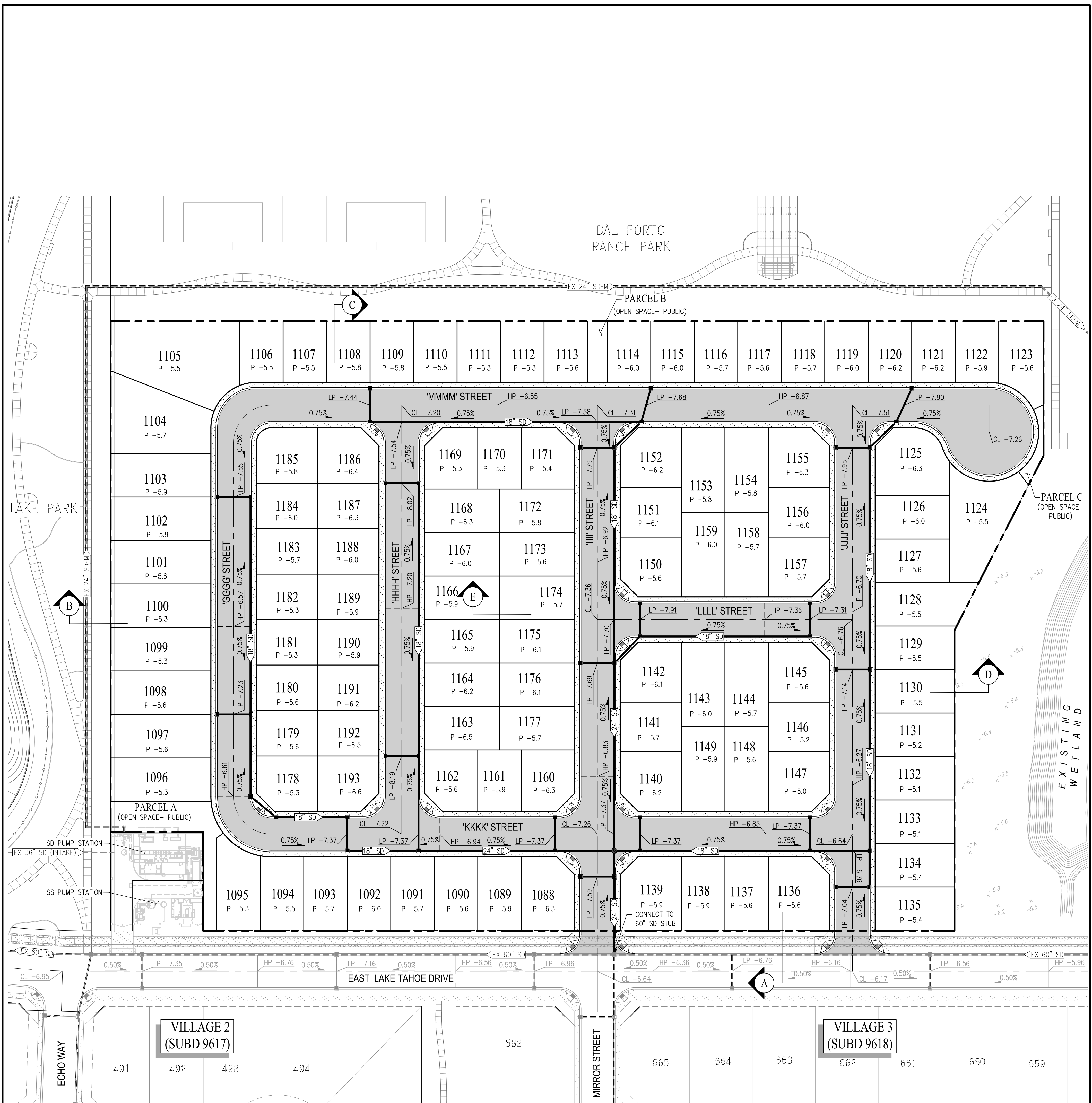

**LEGEND**

- PROJECT BOUNDARY
- PROPOSED RIGHT OF WAY
- PROPOSED LOT LINE
- PROPOSED FACE OF CURB
- EXISTING EASEMENT
- 15" SD
- MANHOLE
- CATCH BASIN
- FIELD INLET

# SUBDIVISION 9660 - VILLAGE 18 SUMMER LAKE NORTH PRELIMINARY GRADING PLAN

CITY OF OAKLEY    CONTRA COSTA COUNTY    CALIFORNIA  
SCALE: 1"=50'    DATE: JUNE 30, 2023

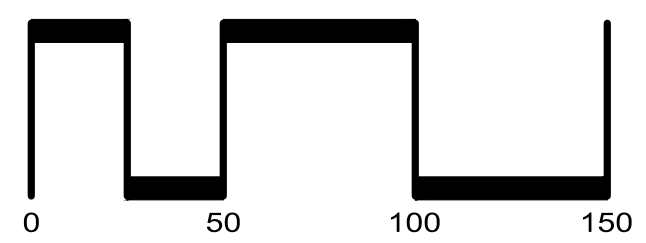
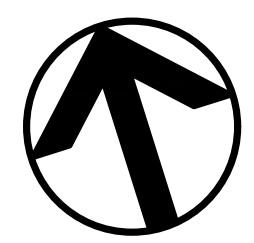

SAN RAMON • (925) 866-0322  
ROSEVILLE • (916) 788-4456  
WWW.CBANDG.COM  
CIVIL ENGINEERS • SURVEYORS • PLANNERS

SHEET NO.  
**TM-2**  
OF 3 SHEETS

G:\1282-18\ACAD\TM\TM02.DWG



VILLAGE 2  
(SUBD 9617)

VILLAGE 3  
(SUBD 9618)

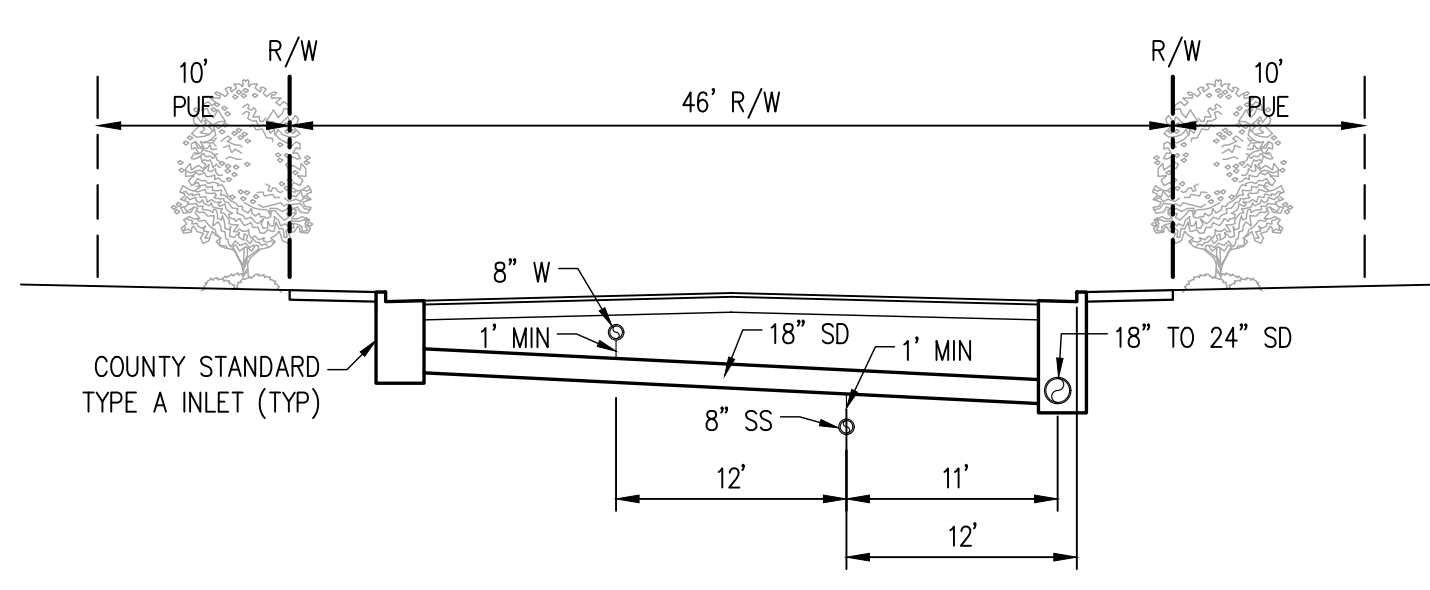

TYPICAL UTILITY SECTION  
46' RIGHT OF WAY  
(NEIGHBORHOOD STREETS)

LEGEND

- PROJECT BOUNDARY
- PROPOSED RIGHT OF WAY
- PROPOSED LOT LINE
- PROPOSED FACE OF CURB
- EXISTING EASEMENT
- 15" SD
- MANHOLE
- CATCH BASIN
- FIELD INLET

# SUBDIVISION 9660 - VILLAGE 18 SUMMER LAKE NORTH PRELIMINARY UTILITY PLAN

CITY OF OAKLEY CONTRA COSTA COUNTY CALIFORNIA  
SCALE: 1"=50' DATE: JUNE 30, 2023

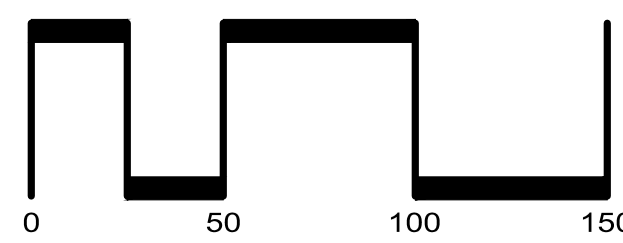
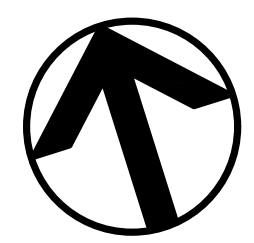

SAN RAMON • (925) 866-0322  
ROSEVILLE • (916) 788-4456  
WWW.CBANDG.COM  
CIVIL ENGINEERS • SURVEYORS • PLANNERS

SHEET NO.  
**TM-3**  
OF 3 SHEETS

G:\1282-118\ACAD\TM\TM03.DWG