

Accessory Structures, Detached Plan Submittal Requirements and Zoning Regulations

This handout is designed to assist you in understanding the applicable regulations and submittal requirements for building or installing a detached accessory structure on your property. An **Accessory Structure** is defined as, “a detached building, carport, gazebo, shed, playhouse, or other similar above-ground structure, the use and size of which is subordinate and incidental to that of a main building on the same lot.”

**Before starting your project,
you are encouraged to check
with the Planning Department
for applicable zoning
regulations.**

It is important to note that almost all accessory structures are subject to zoning regulations, which usually apply to the structure’s floor area, setbacks to property lines, maximum height, and design. Before starting your project, you are encouraged to check with the Planning Department [925-625-7000](tel:925-625-7000) planninggroup@ci.oakley.ca.us for applicable zoning regulations.

Do I need a Building Permit? All accessory structures require building permits except as noted in the 2019 California Building Code (CBC) section [A]105.2

“Work exempt from permit”, which specifies no building permit is required for “One-story detached accessory structures used as tool and storage sheds, playhouses and similar uses, provided the floor area does not exceed 120 square feet”. Please note that a permit would be required for any electrical, plumbing or mechanical that is run to, or installed in, an accessory structure even if the structure does not exceed 120 square feet.

I’ve talked to Planning and need a Building Permit. Now what? Great! You’ve learned about all the applicable size, setbacks, and height restrictions for your new structure, and you are ready to submit plans for your building permit. These steps should get you headed in the right direction. And as always, if you need clarification on any of the following information, Staff is available to help explain the requirements. [Plans will need to be submitted electronically to inspections@ci.oakley.ca.us](mailto:inspections@ci.oakley.ca.us), for any questions please call (925) 625-7005.

Before Submittal please contact:

Contra Costa County Public Works Drainage Fees- Vicki Liu, Vickie.Liu@pw.cccounty.us [925-646-1269](tel:925-646-1269) for properties wanting to build accessory structures, pools, residential units etc. Please have Jeff verify if any drainage fees are due or not and submit to the Building Department proof of contact with him at time of plan submittal.

Contra Costa Environmental Health [925-608-5500](tel:925-608-5500): Approval stamp is required for properties that have septic tanks. Copy of approval needs to be turned in to the Building Department at time of plan submittal.

Iron House Sanitary District ironhousesd@isd.us.com [925-625-2279](tel:925-625-2279) for any projects with new plumbing additions, kitchen, bathrooms, sinks etc... need to obtain approval from Iron house Sanitary and submit copy of their approval to the Building Department.

Plan requirements for accessory structures:

After checking in with the above agencies and obtaining the necessary approvals, below are the requirements to follow to submit to the Building Department to obtain a Building permit.

1. **Preliminary Title Report:** A copy of the property's preliminary title report, usually available from your title company should be submitted along with the plans and permit application for all accessory structures.
2. **Plot Plan:** An aerial view of the existing property that shows the property lines, the existing house, pools, spas, other existing accessory structures, septic systems, easements, retaining walls, and the location of the proposed new accessory structure and provide height of structure to highest point of roof to existing grade. Show setbacks to property lines and the dimensions/floor area of all existing and proposed structures. Measurements should always be in feet and inches, rather than decimal feet (Ex. 3'6", rather than 3.5'), and be made to the closest portion of the accessory structure, such as a roof overhang if it extend closer than the exterior wall. If provided, include the general location of utility and plumbing trenches to the new proposed structure. The property owner's name, phone number, and the address of the project should be on the plot plan or first page of the plan set.
3. **Lot Coverage:** In order for the Planning Department to approve the building permit, you must submit the existing and proposed total lot coverage percentage. Lot coverage is obtained by taking the square footage of all covered structures on the lot (Ex. The main home, patio covers, covered porches, tool sheds, other accessory structures, etc.), regardless if they required a permit, and dividing the lot size into that number. With two or more story structures, use the footprint only. A maximum of 40% lot coverage or a maximum total addition of 500 sf. of attached and detached accessory structures is allowed, whichever is greater. (Ex. 6,000 sf. lot. with a 1,600 sf. house footprint. Adding a 500 sf. detached garage. $(1,600 + 500) / 6,000 = 2,100 / 6,000 = .35$ or 35% lot coverage.) In addition, an accessory structure shall occupy no more than thirty percent (30%) of a required side and/or rear yard. Please contact the Planning Department to learn more about maximum lot coverage and maximum required yard coverage.
4. **Foundation Plan:** Show the size and depth of foundation perimeter walls, slabs, or pier holes. Include details of concrete reinforcement and hold down hardware for larger buildings such as garages and pool houses.
5. **Framing Plan:** This plan details the general assembly of the framing and includes lumber sizes, spacing of the members, location of posts and beams and how the members are to be connected including the type, size and spacing of hardware and fasteners.

6. **Roof Plan**: Include a roof framing plan that details the size and spacing of rafters, ceiling joists, roof sheathing, and the roof covering materials. For simple structures like patio covers, the roof framing can be included with the Framing Plan.
7. **Floor Plan**: For more complex structures like garages or pool houses, provide a floor plan that includes the location of interior walls (if any) and the uses of rooms (if more than one). Include the size and location of windows and doors and the location of electrical, plumbing and mechanical features. Note that the electrical receptacles in most accessory buildings must be GFCI protected.
8. **Structural Calculations**: Provide structural engineering calculations for larger or more complex buildings. Examples of elements that might require engineering include roof trusses, floor trusses, shear walls and the size and spans of beams and headers.

Common Situations

We often find accessory structures built without a permit that are closer than 3' to the property line, and this creates an enforcement problem for the City because it means they will have to move, remove, or make major alterations to their structure to comply. The City of Oakley requires a minimum 3' set back to all accessory structures even for small sheds and playhouses that are less than 120 square feet and do not require a permit (OMC section [A]105.2), the setback is measured to the furthest projection of the eaves, not the structure wall (no part of the structure closer than 3'). All other accessory structures require a permit and must have a 5' setback unless the sides adjoining the property line(s) are of 1 hour fire rated construction but can never be closer than 3' as mentioned above.

Below find examples of what your plans should look like:

Roof Plan

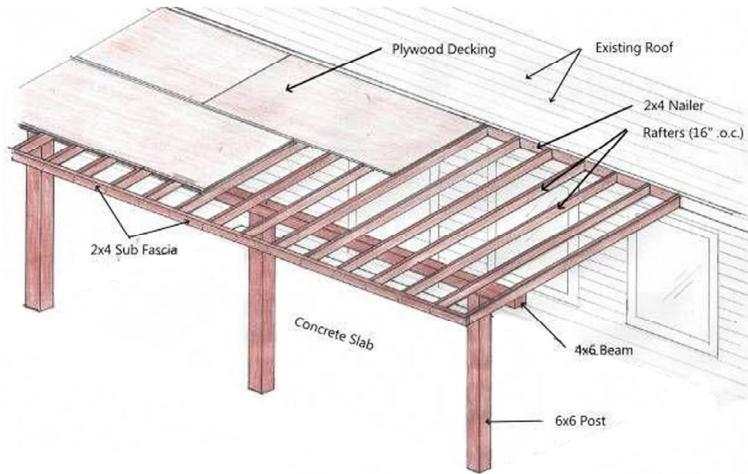

Floor Plan

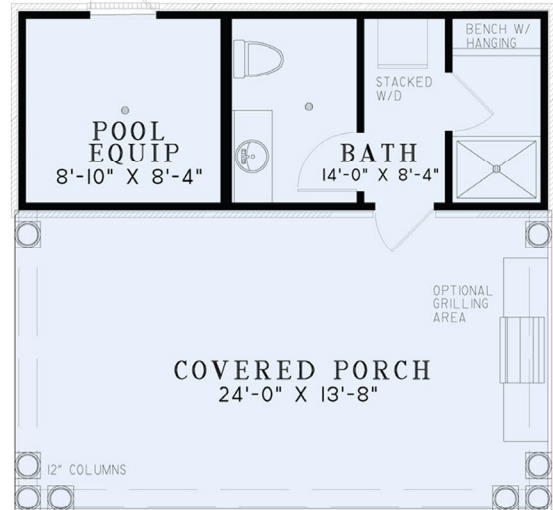

Plot Plan

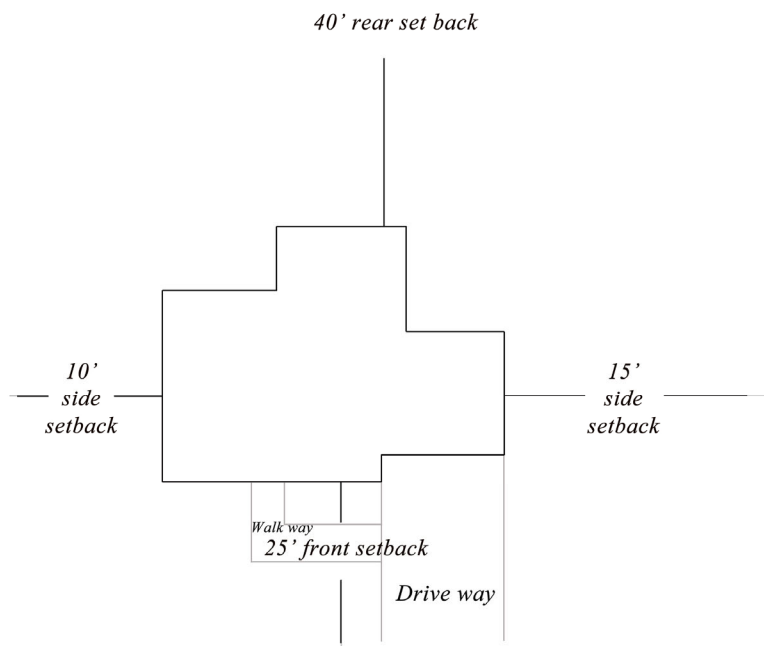

Lot Coverage

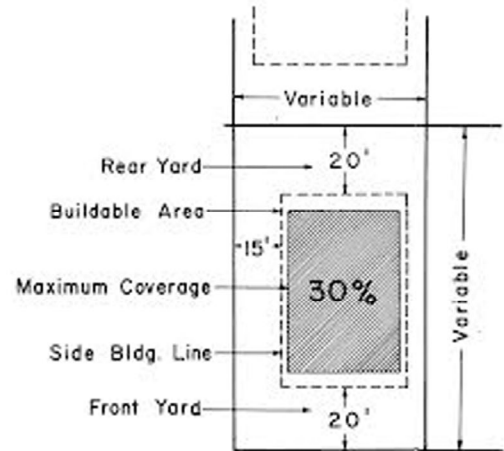

Framing plan

Foundation Plan

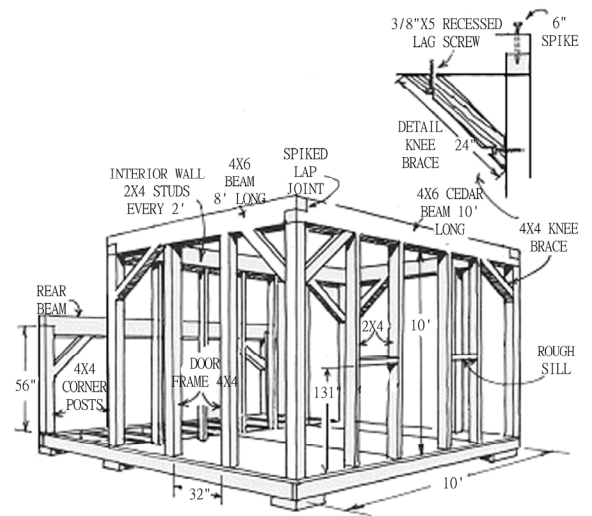
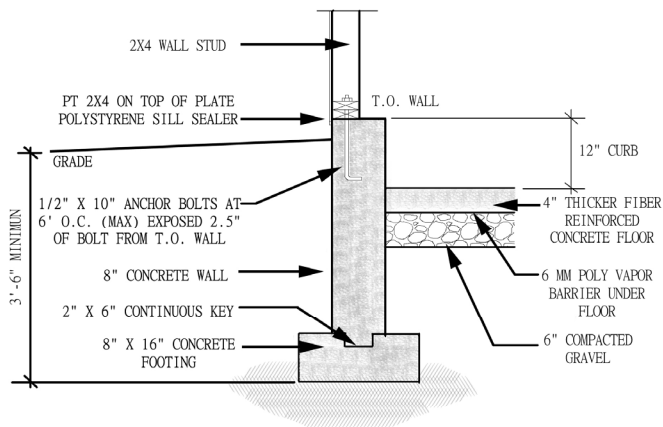

For more information regarding accessory structures, please visit Oakley Municipal Code section 9.1.1802. The Municipal Code is available on the home page of Oakley's website, located at www.oakleyinfo.com.