



# **STANDARD PLANS**

**Prepared By:**

**The City of Oakley  
Public Works and Engineering Department**

**JUNE 2016**

**OAKLEY**



**CALIFORNIA**

*3231 Main Street  
Oakley, CA 94561*

## INTRODUCTION

The City of Oakley presents the first volume of Standard Plans developed by the Public Works and Engineering Department. The City of Oakley has adopted the Caltrans Standard Plans, but the City of Oakley Standard Plans are specific to the City's public improvements. The City Standard Plans will govern between conflicting details with Caltrans and Contra Costa County standard details.

These drawings shall be used in conjunction with the latest edition of the Caltrans Standard Specifications, Standard Specifications for Public Works Construction (i.e. "The GREENBOOK"), and project specific City of Oakley Specifications.

All details pertaining to the design of potable water, recycled water and sanitary sewer systems shall be reviewed and approved by Diablo Water District and Ironhouse Sanitary District respectively.

All curb ramps and accessible routes shall conform to Caltrans Standards, Americans with Disabilities Act Accessibility Guidelines (ADAAG), and Title 24 of the California Building Code.

These drawings are not to scale; therefore, they must be used with care and judgment.

A hard copy of the City of Oakley Standard Plans is available for purchase at the City of Oakley Permit Center located at 3231 Main Street, Oakley, CA 94561.

## COMMENTS

The City of Oakley is committed to the quality of this publication and desires to correct any errors, omissions or ambiguities in the next publication of this document. If you have any comments, corrections, or additions you would like to submit for consideration to be included in the next publication, you are encouraged to submit them to:

City of Oakley  
Public Works and Engineering Department  
3231 Main Street  
Oakley, CA 94561

(925) 625-7037

[publicworks@ci.oakley.ca.us](mailto:publicworks@ci.oakley.ca.us)

## TABLE OF CONTENTS

DESCRIPTION	PAGE #
<b>STREETS</b>	
Typical Sections – Major Roads.....	X-01
Typical Sections – Residential.....	X-02
Street End Layout Options.....	X-03
Driveway and Intersection Sight Triangles.....	X-04
Concrete Curb & Gutter.....	C-01
Concrete Vertical Curb.....	C-02
Concrete Divider/ Mowing Band.....	C-03
Concrete Sidewalk - Monolithic & Separated .....	C-04
Concrete Driveway with Planter .....	C-05
Concrete Driveway without Planter.....	C-06
Concrete Driveway to Sidewalk Reconstruction.....	C-07
HMA Conform Details.....	C-08
Speed Hump .....	C-09
<b>STORM DRAIN</b>	
Curb Drain.....	SD-01
Concrete Valley Gutter.....	SD-02
Pipe Trench Detail.....	SD-03
Pipe Trench Notes.....	SD-04
Manhole/Catch Basin & Valve Box Adjustment.....	SD-05
Standard Manhole.....	SD-06
Manhole Frame and Cover.....	SD-07
Type I Curb Inlet.....	SD-08
Type II Inlet.....	SD-09
Type III Landscape Area/Park Inlet.....	SD-10
Reticuline Frame & Grate.....	SD-11
Storm Drain Marker.....	SD-12
<b>ELECTRICAL</b>	
Street Light – Cobra Head Double LED.....	E-01
Street Light – Cobra Head Single LED.....	E-02
Street Light – Decorative Double LED.....	E-03
Street Light – Decorative Single LED.....	E-04
Signal Specifications and Equipment List.....	E-05

## TABLE OF CONTENTS *(continued)*

<b>DESCRIPTION</b>	<b>PAGE #</b>
<b>SIGNS</b>	
Street Name Sign – Major Street.....	SS-01
Street Name Sign – Minor Street.....	SS-02
Street Name Sign – Location and Mounting.....	SS-03
<b>LANDSCAPE</b>	
Preferred Tree List.....	L-01
Tree Planting Specifications.....	L-02
Tree Planting .....	L-03
Shrub Planting .....	L-04
<b>IRRIGATION</b>	
Irrigation Equipment List.....	IR-01
Irrigation System Thrust Blocking.....	IR-02
Irrigation Controller.....	IR-03
Irrigation Controller Enclosure Top Opening.....	IR-04
Master Valve and Flow Sensor.....	IR-05
Flow Sensor Detail.....	IR-06
CCU or Field Satellite Grounding Grid.....	IR-07
Irrigation Valve Box Installation.....	IR-08
Irrigation Wire Connection.....	IR-09
Remote Control Valve.....	IR-10
Quick Coupling Valve.....	IR-11
Gate/Ball Valve.....	IR-12
Rotor and Pop-Up Spray Head.....	IR-13
Shrub Bubbler and Flexible Riser .....	IR-14
Irrigation Electric Meter Pedestal.....	IR-15
<b>MISCELLANEOUS</b>	
Park Furnishings .....	M-01
Removable Bollard Park or Trail .....	M-02
Fence – Chain Link.....	M-03
Solid Waste Trash Enclosure.....	M-04

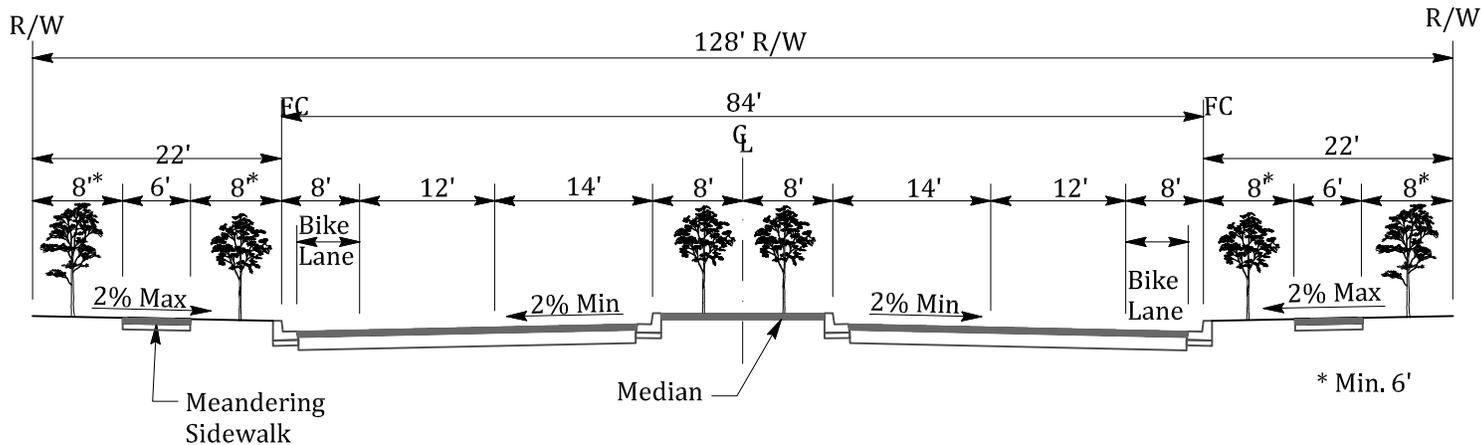

### FOUR LANE DIVIDED

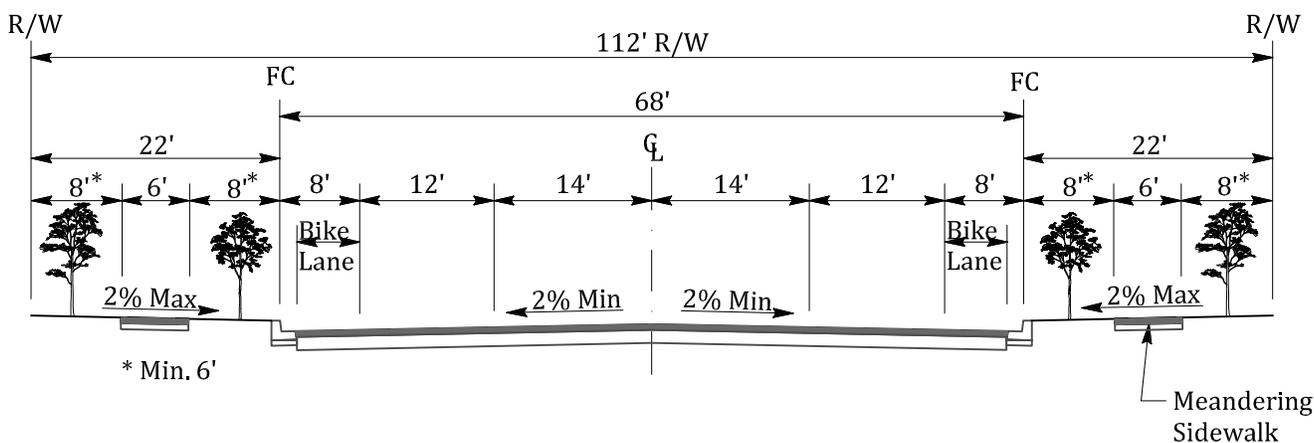

### FOUR LANE UNDIVIDED

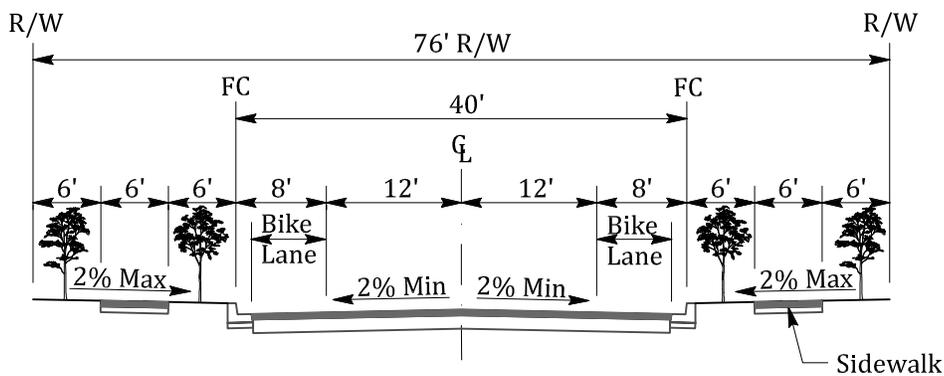

Minimum Structural Section: 3" AC / 6" AB

### TWO LANE COLLECTOR/ARTERIAL

FC = Face of Curb

NOT TO SCALE

APPROVED BY		DATE		<b>TYPICAL SECTIONS MAJOR ROADS</b>	STD. PLAN NO.
 CITY ENGINEER		JUNE 2016			<b>X-01</b>
		rev 12/7/17			

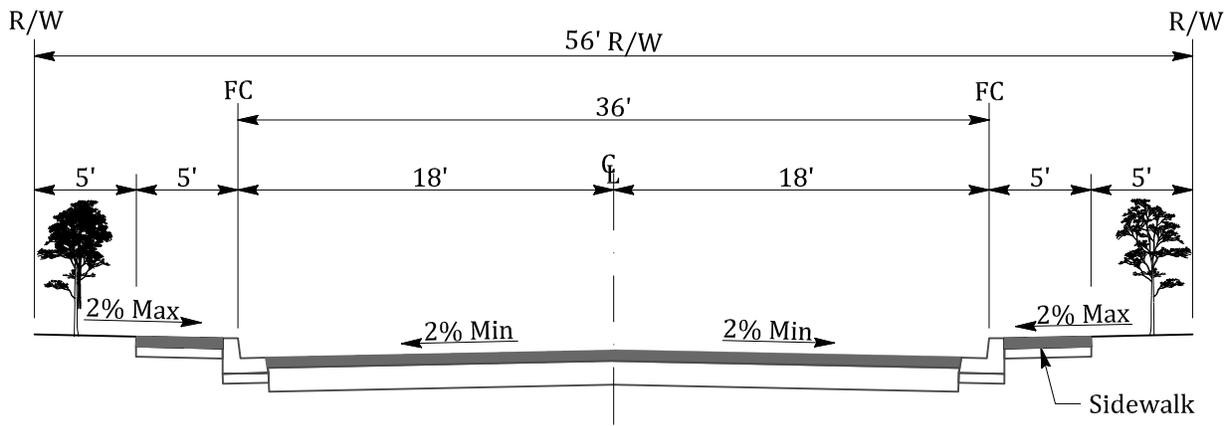

MINOR/RESIDENTIAL STREET

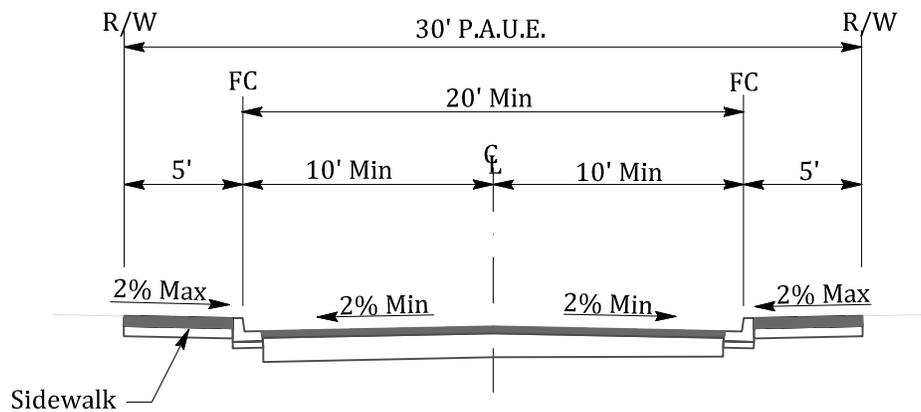

PRIVATE ACCESS ROAD

Minimum Structural  
Section: 3"AC / 6" AB

NOTES:

1. Sidewalk per the approval of the Planning Department.
2. Street widths subject to the approval of the Fire District and Planning Department.

FC=Face of curb

NOT TO SCALE

APPROVED BY	DATE		<b>TYPICAL SECTIONS RESIDENTIAL</b>	STD. PLAN NO.
	JUNE 2016			X-02
CITY ENGINEER	rev 12/7/17			

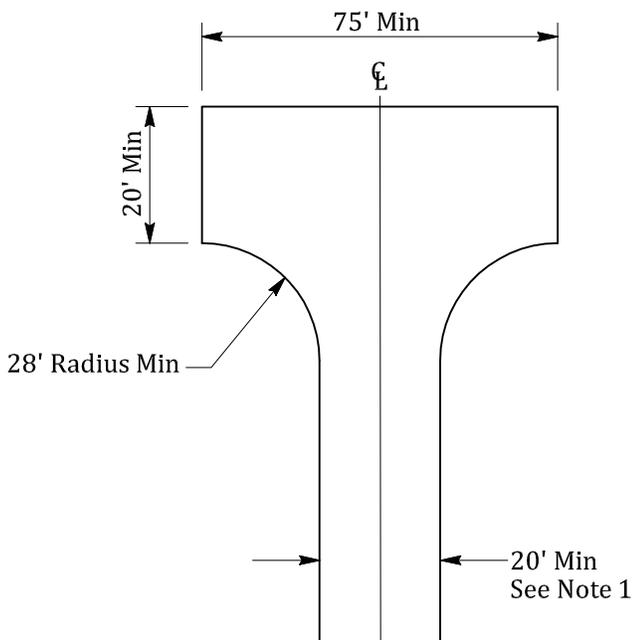

**HAMMERHEAD**  
(Private Only)

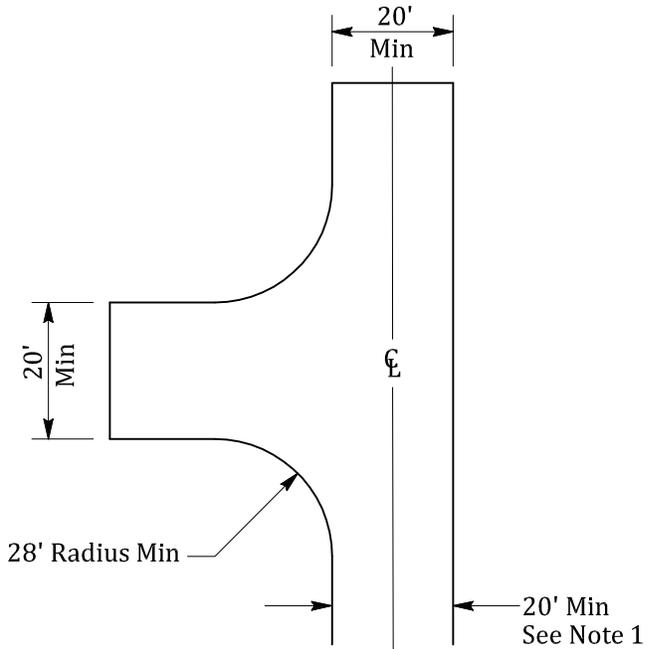

**SHUNT**  
(Private Only)

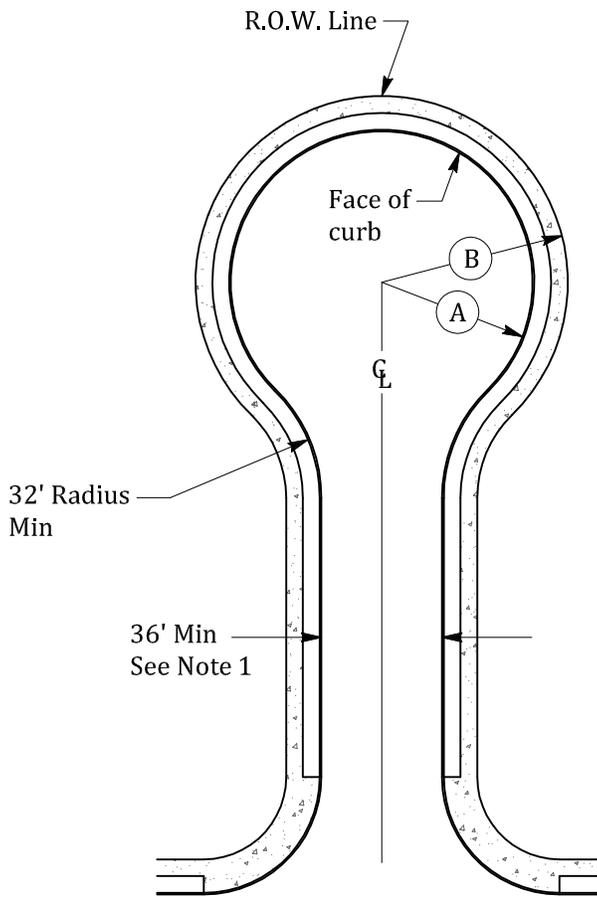

**CUL-DE-SAC**

ROAD TYPE	RADIUS	
	(A)	(B)
Residential Street	45'	55'
Commercial/ Industrial Street	55'	65'

**NOTES:**

1. Minimum Roadway widths:  
20 Feet - no parking  
32 Feet - parking on one side  
36 Feet - parking on both sides
2. Cross slope within turnaround shall not exceed 8% grade.
3. Surface shall be all-weather and capable of supporting a 37 ton vehicle.
4. Cul-de-Sac shall have standard curb and gutter, See Std Plan C-01.
5. Standards are minimum City requirements subject to Fire District approval.

NOT TO SCALE

APPROVED BY	DATE		<b>STREET END LAYOUT OPTIONS</b>	STD. PLAN NO.
 CITY ENGINEER	JUNE 2016			X-03

**NOTES:**

1. Foliage at maturity and berm, if any, shall not exceed 3 feet in height.
2. A visual clearance from the street to 15 feet in height shall be maintained with all tree foliage within the sight triangle.
3. A visual clearance from the sidewalk to 7 feet in height shall be maintained with all tree foliage within the sight triangle.
4. Site specific sight triangle exhibit to be provided upon request by the Public Works and Engineering Department

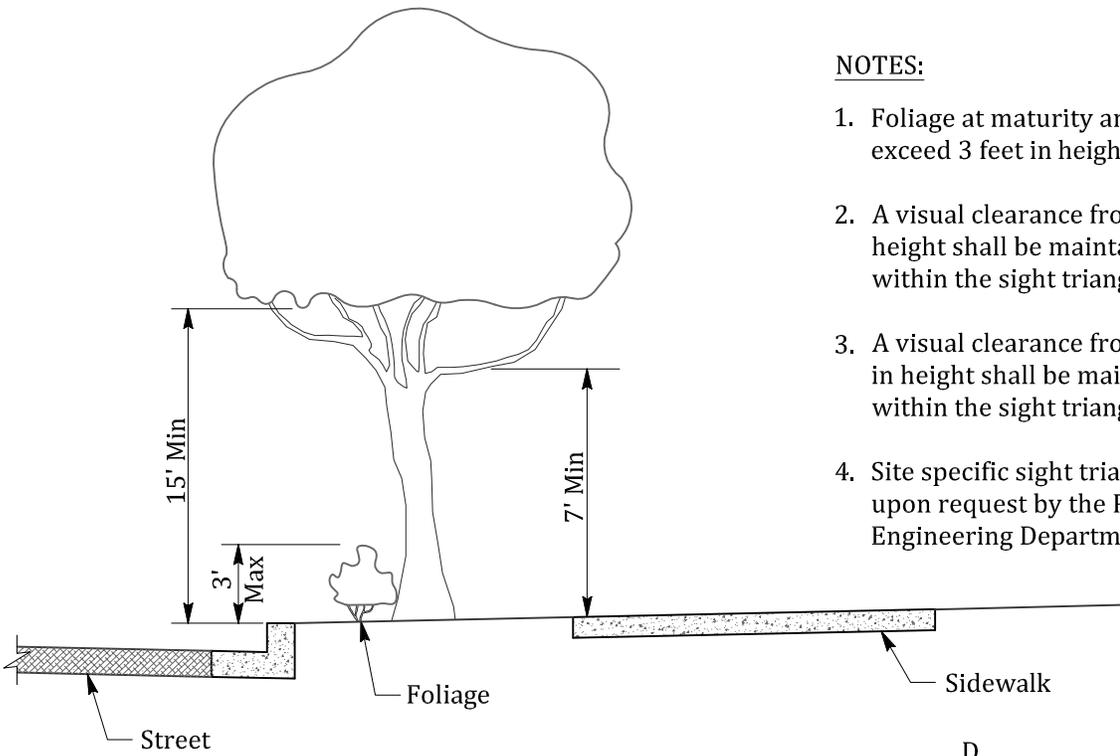

MAJOR ROAD POSTED SPEED LIMIT (MPH)	D MINIMUM DISTANCE (FT)*
25	280
30	335
35	390
40	445
45	500

\* AASHTO GREEN BOOK

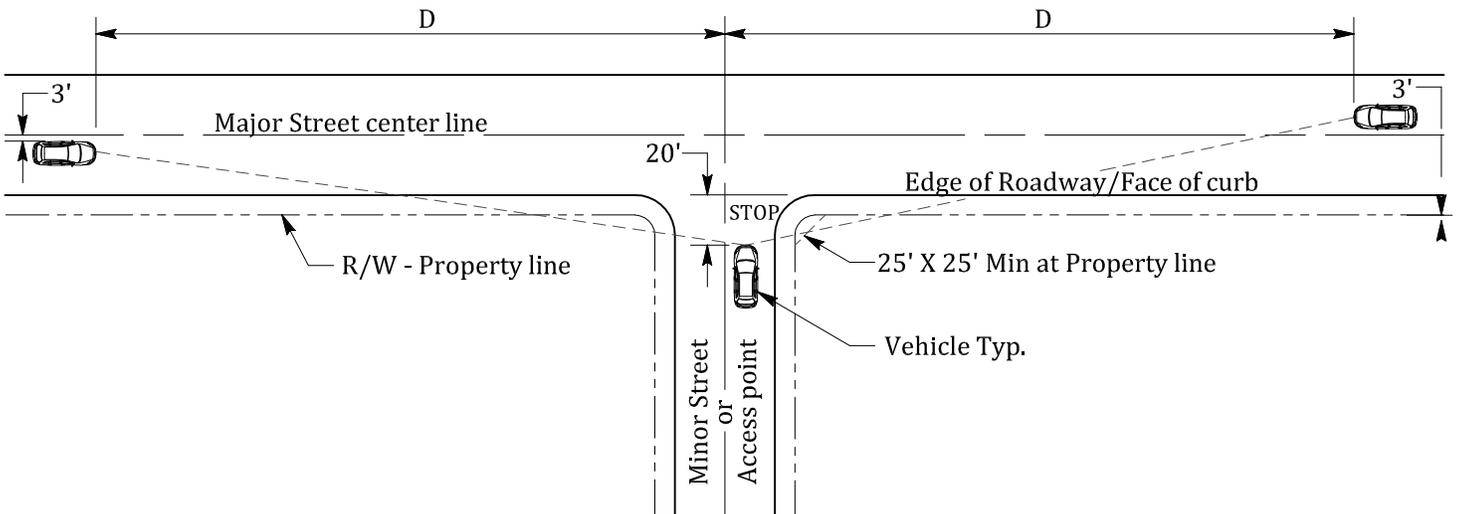

**MAJOR STREET WITH STOP CONTROL ON MINOR STREET**

NOT TO SCALE

APPROVED BY	DATE		<b>DRIVEWAY AND INTERSECTION SIGHT TRIANGLES</b>	STD. PLAN NO.
 CITY ENGINEER	JUNE 2016			X-04

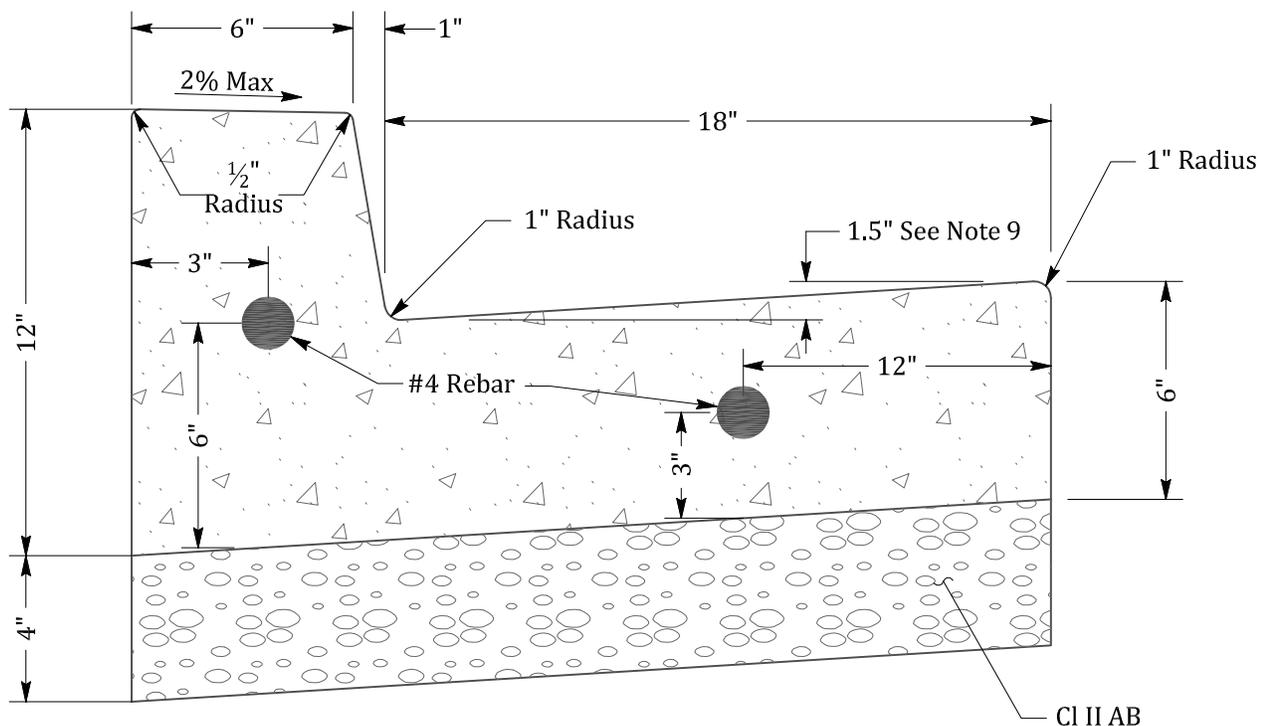

**NOTES:**

1. All radii less than 100' shall use flexible wood or metal forms to eliminate angular points at 10' section points.
2. Sawcut and remove 18 inch minimum street section for curb and gutter installation on existing streets.
3. 3/4" expansion joints to be placed at driveway sections, curb returns curb ramps & cold joints or a maximum of 30' center to center. Expansion joints shall protrude 1" below the bottom of gutter.
4. Thru joints shall be placed adjacent to catch basins, inlets at points of tangency on streets, and at alley and driveway returns. Maximum spacing shall be 30' pre-molded joint filler, shall be 1/2" wide and conform to AASHTO design M213. Dummy joints shall be placed every 10'.
5. Finished work shall not vary more than 1/8" in grade and 1/4" in alignment.
6. The finished curb shall immediately be sprayed with a transparent curing compound. Curb shall be covered by waterproof paper or plastic membrane in the event of rain or other unsuitable weather. Curing time shall be a minimum of 72 hours.
7. All curb and gutter shall be placed on a minimum of 4" Aggregate Base Class II 95% maximum compaction ASTM D1557.
8. #4 Rebar shall be extended along full length of the curb and gutter.
9. Gutter pan slope shall not exceed 5% at pedestrian curb ramp entry locations. Contractor shall use 1.2" maximum between lip of gutter flow line at these locations.
10. All concrete shall be per current Caltrans Specifications Section 73 "Concrete Curbs and Sidewalks" and Section 90 "Concrete". Concrete shall include two (2) pounds of liquid lamp black per cubic yard of concrete. Liquid lamp black color shall be "Davis A 8090 Black" or equal.
11. All curb and gutter shall have 2-#4 Rebar the entire length and embedded on both end using dowels (one dowel in the center of the gutter, one dowel in the center of the curb).

NOT TO SCALE

APPROVED BY	DATE		<b>CONCRETE CURB AND GUTTER</b>	STD. PLAN NO.
 CITY ENGINEER	APRIL 2017 Rev. 4/19/17			C-01

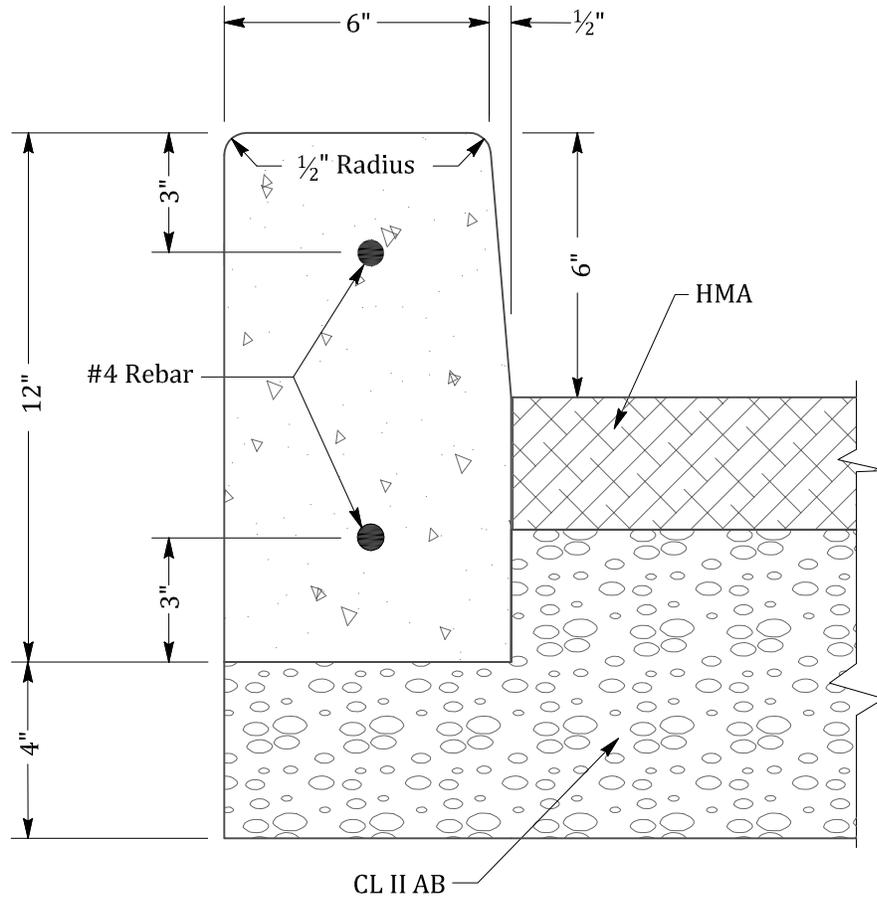

**NOTES:**

1. The construction notes of Standard Plan C-01 apply to concrete vertical curb.
2. Median islands shall have 8" vertical clearance from Top of Curb to Pavement.

NOT TO SCALE

APPROVED BY	DATE		<b>CONCRETE VERTICAL CURB</b>	STD. PLAN NO.
<i>Kevin Rohani</i>	JUNE 2016			C-02
CITY ENGINEER				

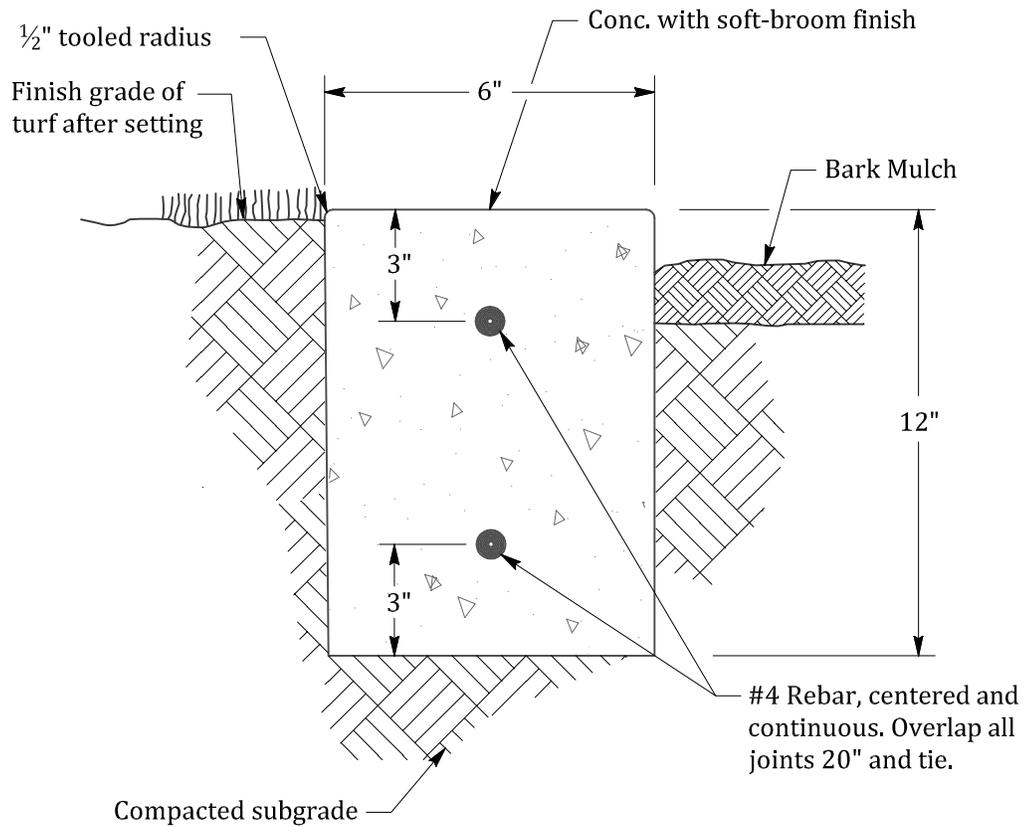

**SECTION**

**NOTES:**

1. Provide 1/4" wide by 1/2" deep score lines at 8'-0" O.C. and expansion joints at 32'-0" O.C.

NOT TO SCALE

APPROVED BY	DATE		<b>CONCRETE DIVIDER/MOWBAND</b>	STD. PLAN NO.
 CITY ENGINEER	JUNE 2016			C-03

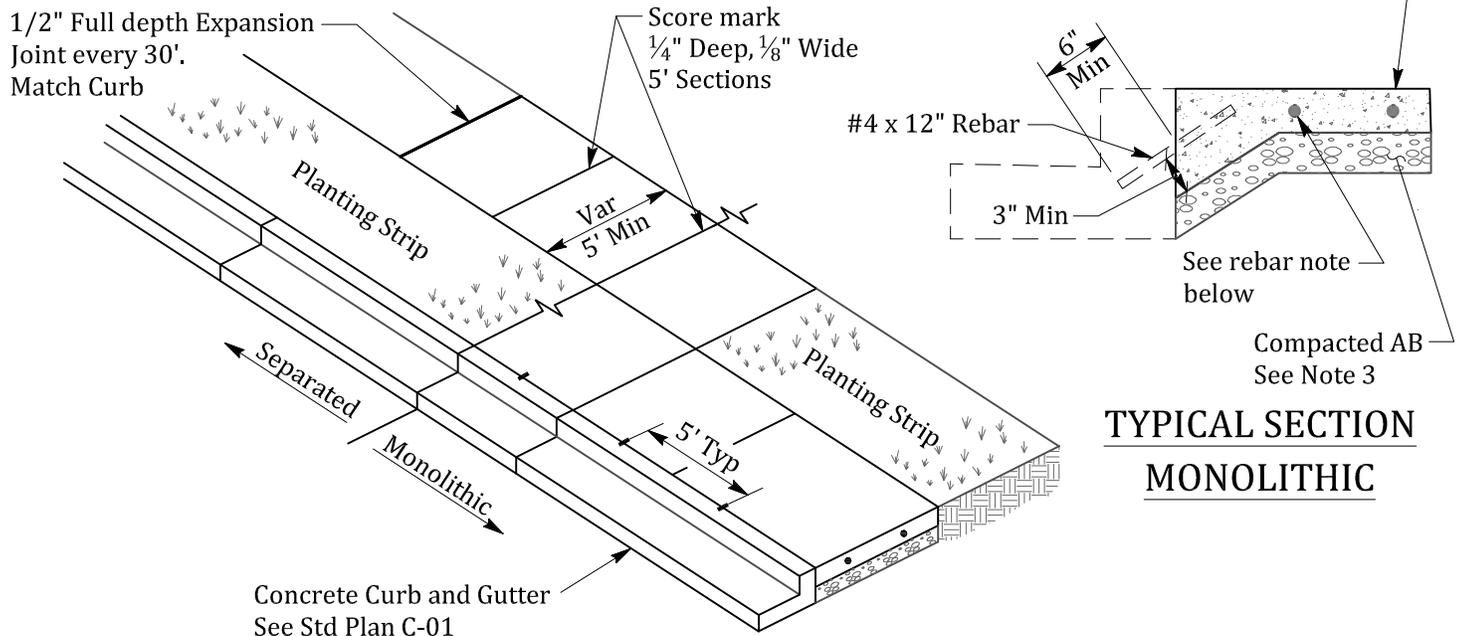

PLAN VIEW

TYPICAL SECTION  
MONOLITHIC

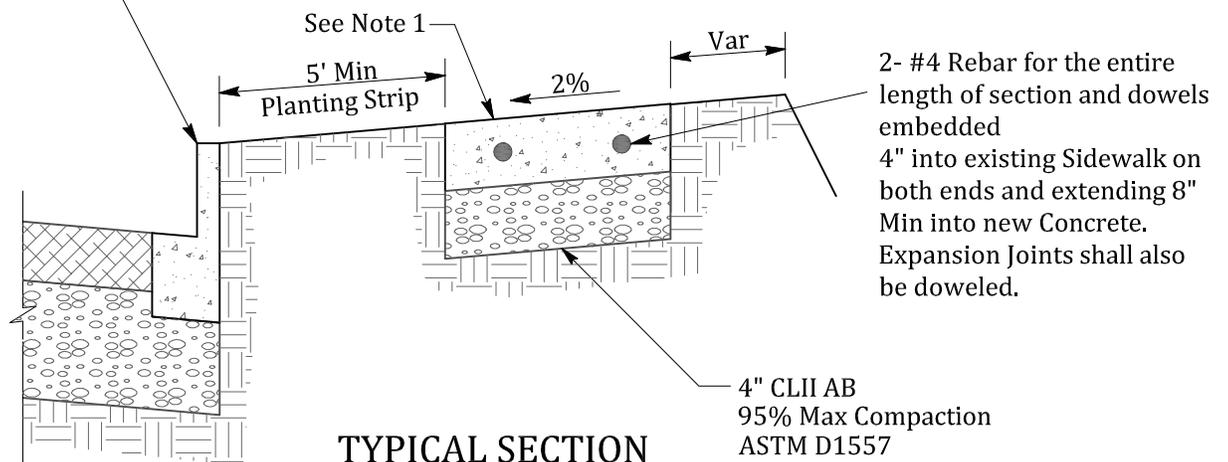

TYPICAL SECTION  
SEPARATED

NOTES:

1. Sidewalk shall be a minimum of 4". All concrete shall be per current Caltrans Specifications Section 73 "Concrete Curbs and Sidewalks" and Section 90 "Concrete". Concrete shall include two (2) pounds of liquid lamp black per cubic yard of concrete. Liquid lamp black color shall be "Davis A 8090 Black" or equal.
2. Full Expansion Joints shall be placed to match those placed in adjacent Curb & Gutter, with maximum spacing of 30 feet.
3. Subgrade shall have 95% maximum compaction ASTM D1557.
4. Sidewalk shall be at least 6" thick behind Rolled Curb and Residential Driveways and 8" thick behind Commercial Driveways.
5. The finished Sidewalk shall be sprayed with a transparent Curing Compound covered by Waterproof Paper or Plastic Sheeting in the event of rain or other inclement weather; curing time shall be for a minimum of 72 hours.
7. All joints shall be cleaned and edged with an edger having a 1/4" radius.
8. Sidewalk and Planter Strip widths shall conform to dimensions shown in appropriate street cross section details.
9. The width of Sidewalk directly behind Curb without Planter shall be a minimum of 5' from back of curb.
10. Exposed surfaces shall be a light broom finish.

NOT TO SCALE

APPROVED BY	DATE		<b>CONCRETE SIDEWALK MONOLITHIC AND SEPARATED</b>	STD. PLAN NO.
 CITY ENGINEER	APRIL 2017 Rev. 9/28/17			C-04

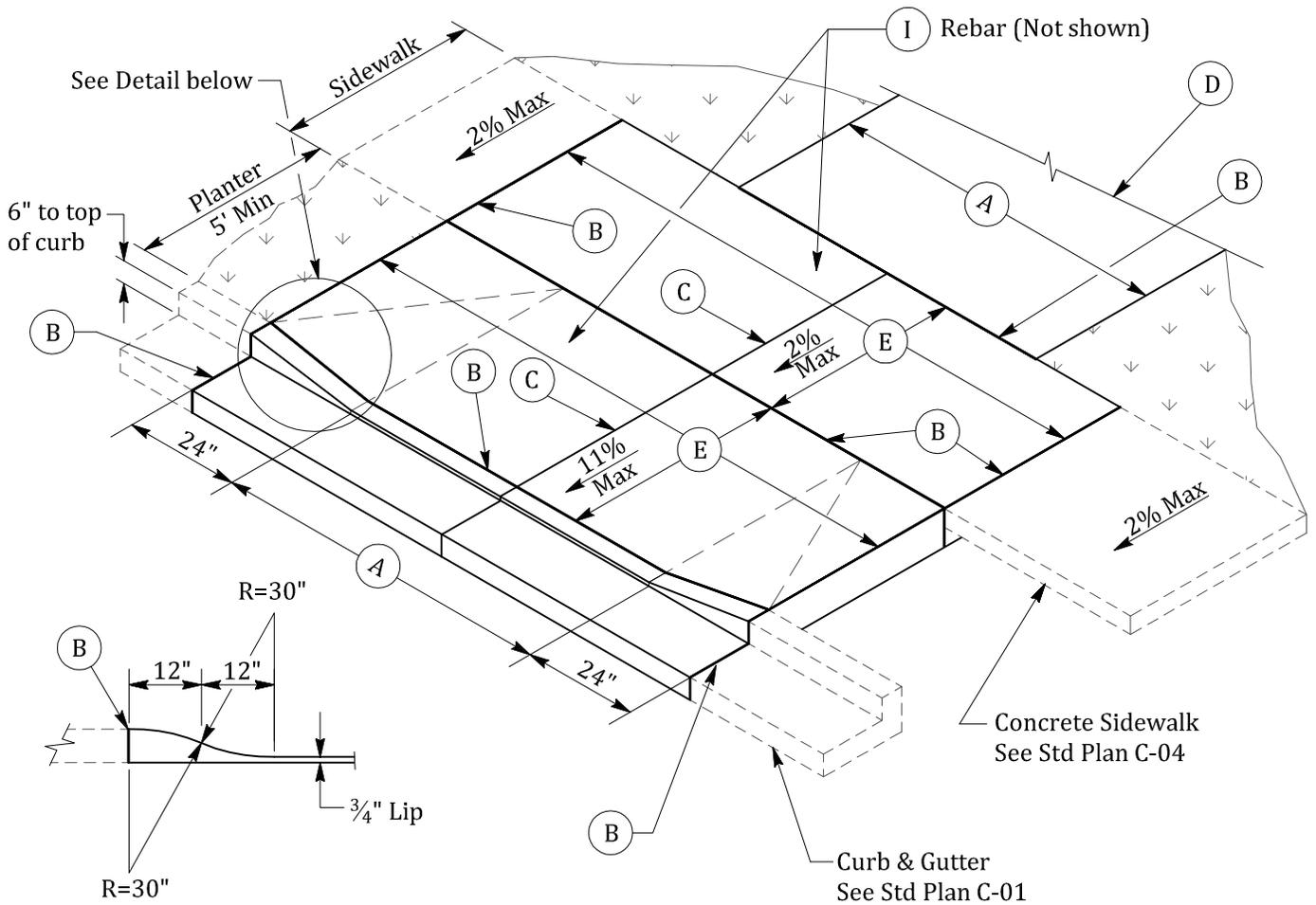

## CURB TRANSITION DETAIL

### NOTES

- (A) Equals width of Driveway at property line, 14' Min - 30' Max for Residential & 25' Min - 35' Max for Commercial.
- (B) ½" wide full depth Expansion Joint.
- (C) Full depth Expansion Joint if (A) is 15' or greater.
- (D) Driveway to be surfaced with asphalt or concrete.
- (E) Driveway concrete shall be a Minimum of 6" thick for Residential & 8" thick for Commercial locations and is to be placed on a minimum of 4" Class II Aggregate Base 95% maximum compaction, ASTM D1557. Over 95% compacted subgrade.
- (F) All concrete shall be per current Caltrans Specifications Section 73 "Concrete Curbs and Sidewalks" and Section 90 "Concrete". Concrete shall include two (2) pounds of liquid lamp black per cubic yard of concrete. Liquid lamp black color shall be "Davis A 8090 Black" or equal.
- (G) Sawcut and remove 18" minimum street section for driveway installation in existing streets.
- (H) All work shall conform to current ADA requirements.
- (I) #4 Rebar 16" O.C. both ways minimum 3" cover.

NOT TO SCALE

APPROVED BY	DATE		<b>CONCRETE DRIVEWAY WITH PLANTER</b>	STD. PLAN NO.
 CITY ENGINEER	APRIL 2017 Rev. 4/19/17			<b>C-05</b>

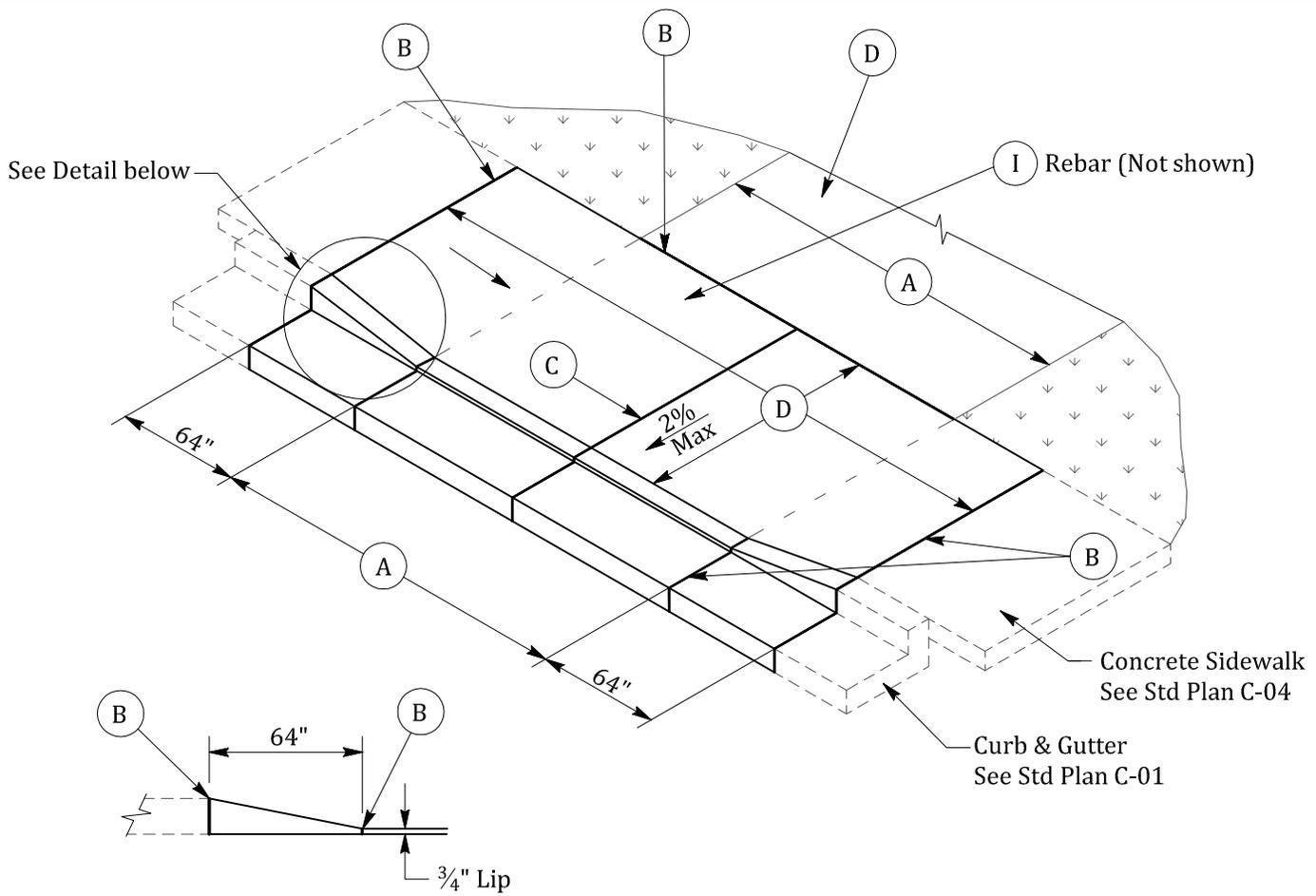

**CURB TRANSITION DETAIL**

**NOTES:**

- (A) Equals width of Driveway at property line, minimum width 14' min. - 30' max for residential and 25' min. - 35' max for commercial.
- (B) 1/2" wide full depth Expansion Joint.
- (C) Full depth Expansion Joint if (A) is 15' or greater.
- (D) Driveway to be surfaced with asphalt or concrete.
- (E) Driveway concrete shall be a Minimum of 6" thick for Residential & 8" thick for Commercial locations and is to be placed on a minimum of 4" Class II Aggregate Base 95% maximum compaction, ASTM D1557. Over 95% compacted subgrade.
- (F) All concrete shall be per current Caltrans Specifications Section 73 "Concrete Curbs and Sidewalks" and Section 90 "Concrete". Concrete shall include two (2) pounds of liquid lamp black per cubic yard of concrete. Liquid lamp black color shall be "Davis A 8090 Black" or equal.
- (G) Sawcut and remove 18" minimum street section for driveway installation in existing streets.
- (H) All work shall conform to current ADA requirements.
- (I) #4 Rebar 16" O.C. both ways minimum 3" cover.

NOT TO SCALE

APPROVED BY	DATE		<b>CONCRETE DRIVEWAY WITHOUT PLANTER</b>	STD. PLAN NO.
 CITY ENGINEER	APRIL 2017 Rev. 4/19/17			C-06

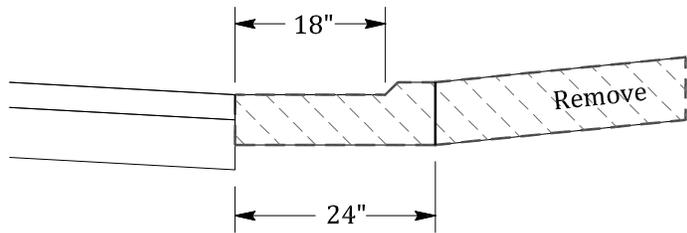
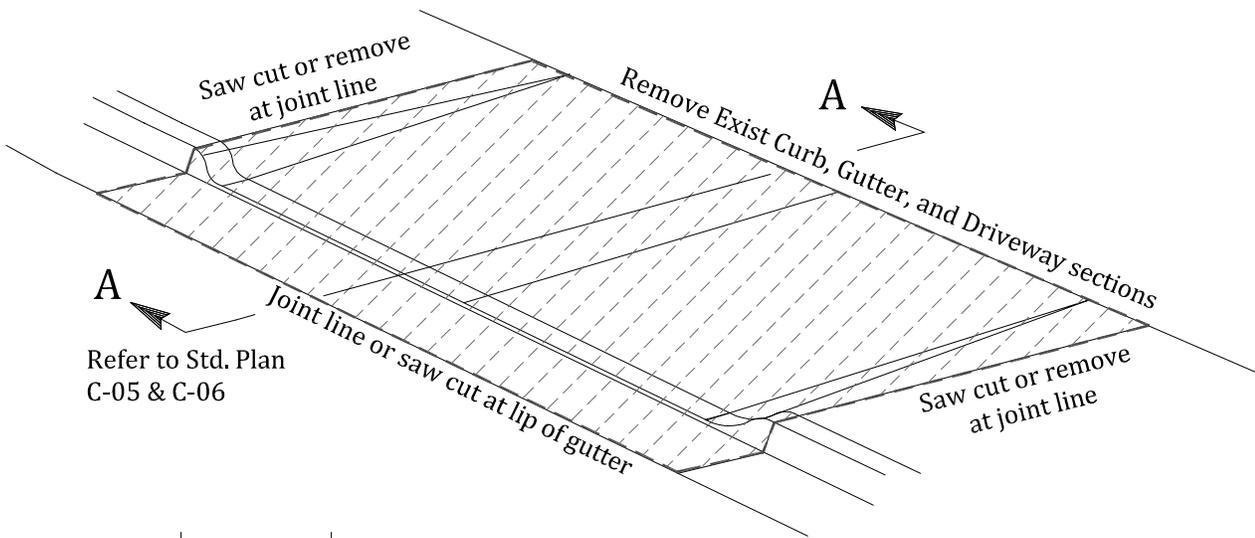

**SECTION A-A**

**NOTE:**

Rebar: #4 @ 16" O.C. both ways, Min 3" concrete coverage

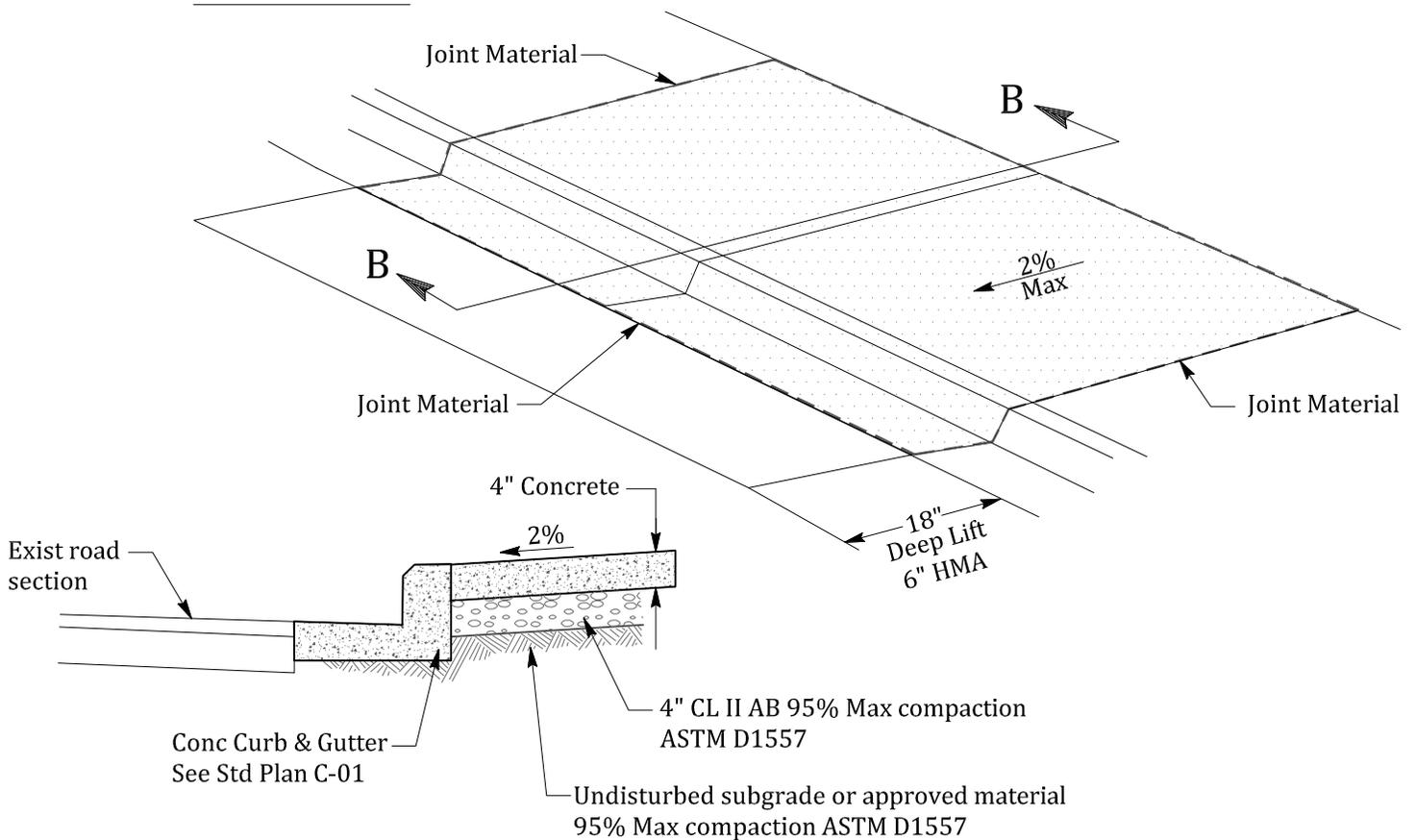

**SECTION B-B**

NOT TO SCALE

APPROVED BY		DATE	<p><b>OAKLEY CALIFORNIA</b></p>	<p><b>CONCRETE DRIVEWAY TO SIDEWALK RECONSTRUCTION</b></p>	STD. PLAN NO.
		JUNE 2016			C-07
CITY ENGINEER					



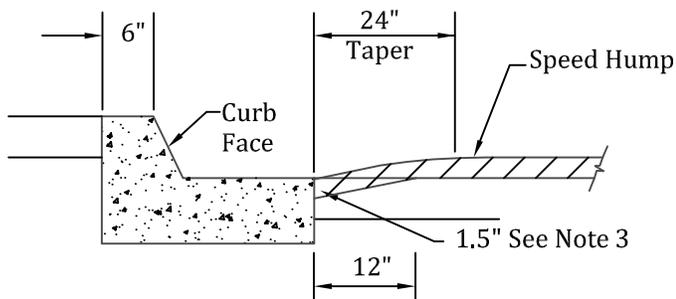
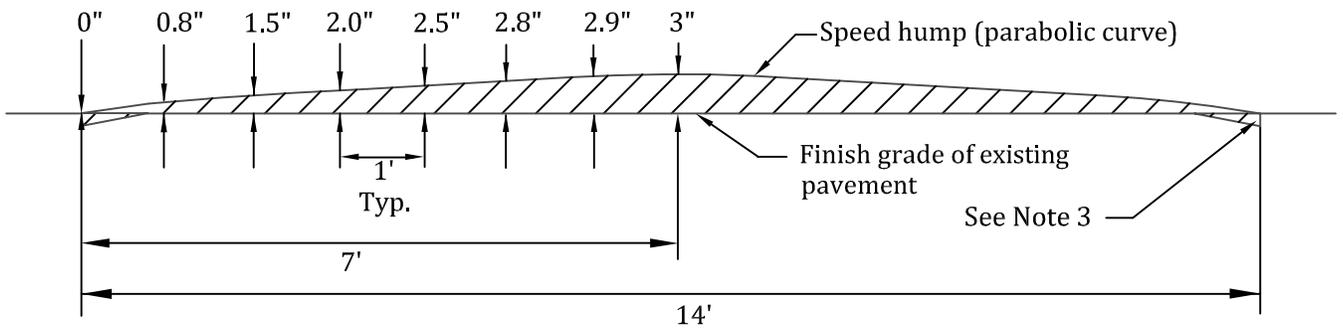
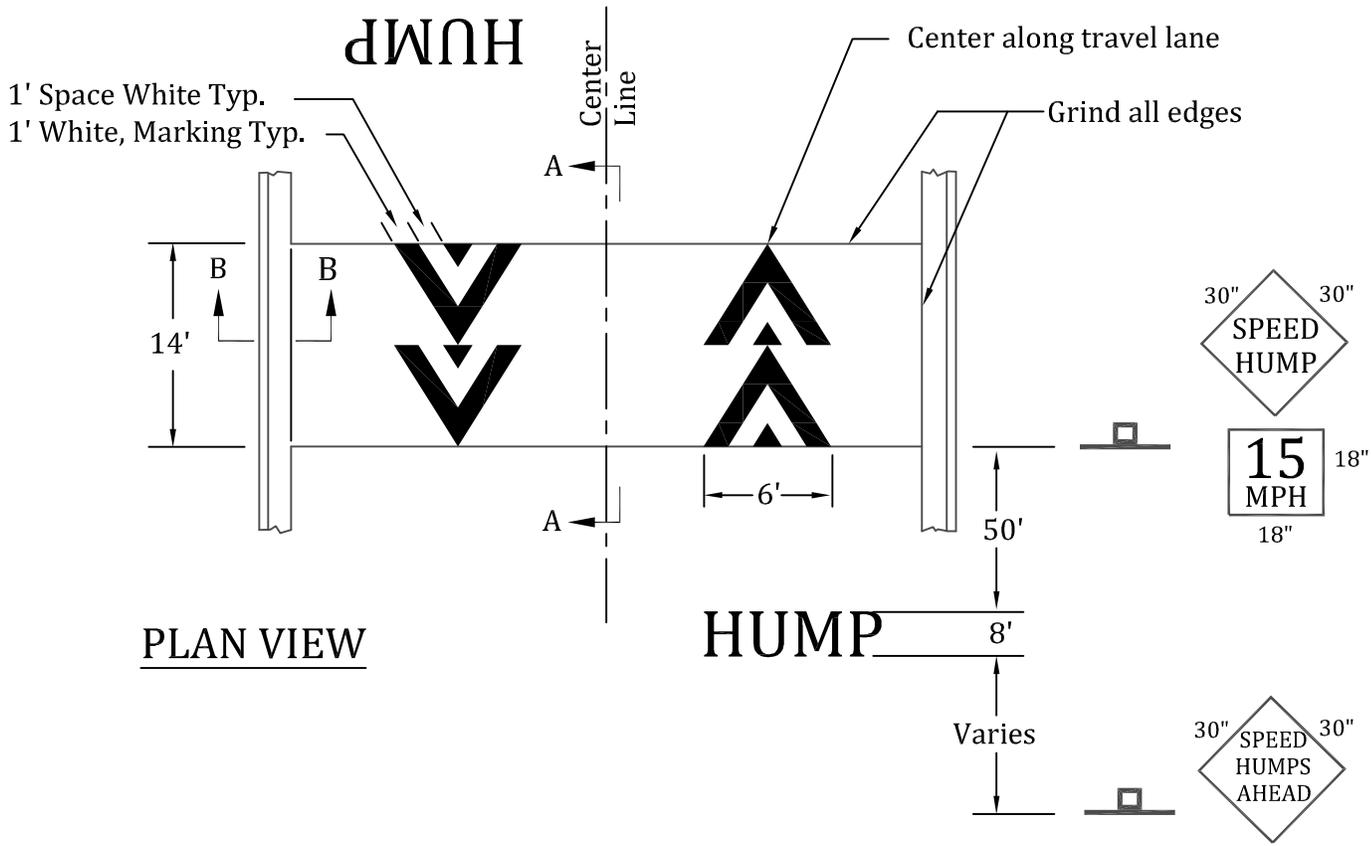

**NOTES:**

1. Speed Hump must be parabolic
2. Type A HMA AR-4000, Max aggregate size 1/2".
3. Grind to key in all edges (1.5" x 12").
4. Signs shown typical in both directions.
5. Sign post must be galvanized square 2"x2" post with 3/8" diameter holes spaced 1" apart.
6. Signs shall be 3M Diamond Grade.
7. All striping shall be thermoplastic paint.
8. Speed Hump installation must adhere to the Neighborhood Traffic Management Policy.

**NOT TO SCALE**

APPROVED BY		DATE		STD. PLAN NO.
		JUNE 2016		<b>SPEED HUMP</b> <b>C-09</b>
CITY ENGINEER		Rev 6/11/17		

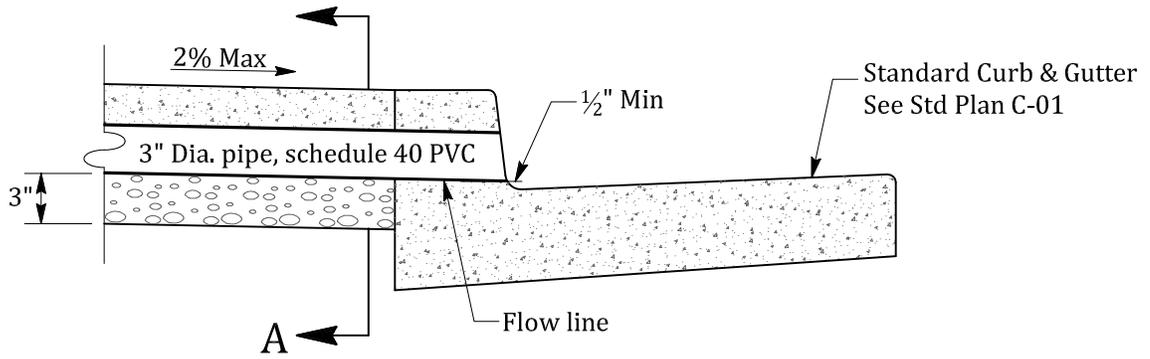

**OPTION 1**

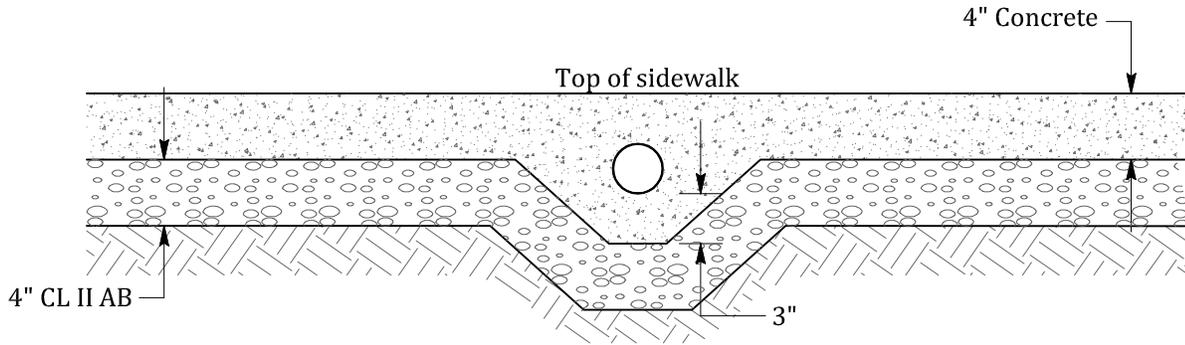

**SECTION A-A**

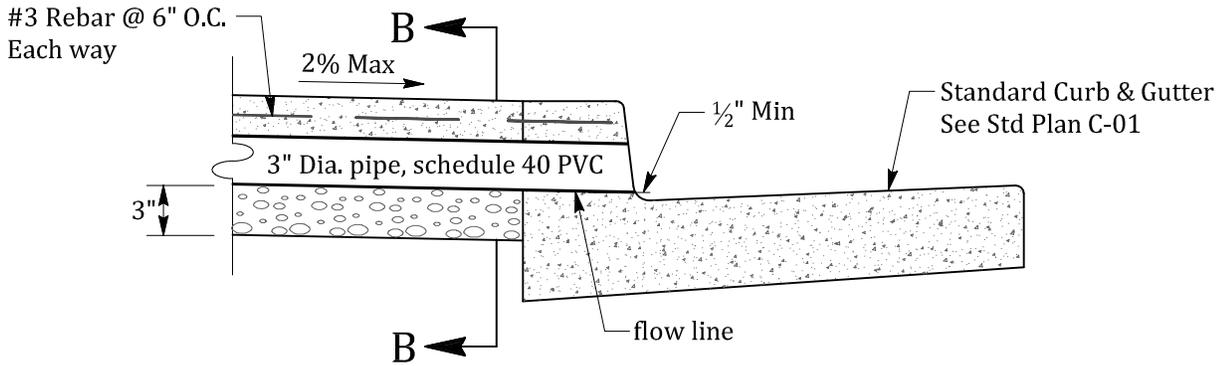

**OPTION 2**

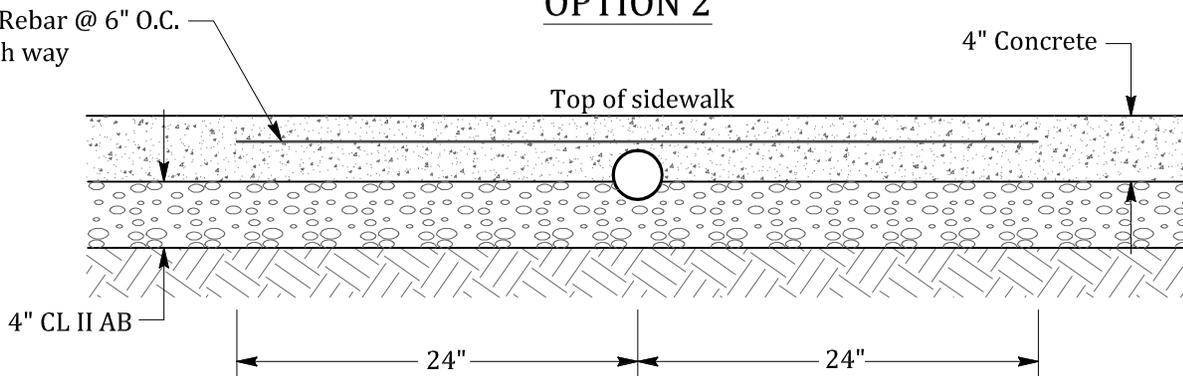

**SECTION B-B**

NOT TO SCALE

APPROVED BY	DATE		CURB DRAIN	STD. PLAN NO.
 CITY ENGINEER	JUNE 2016			SD-01

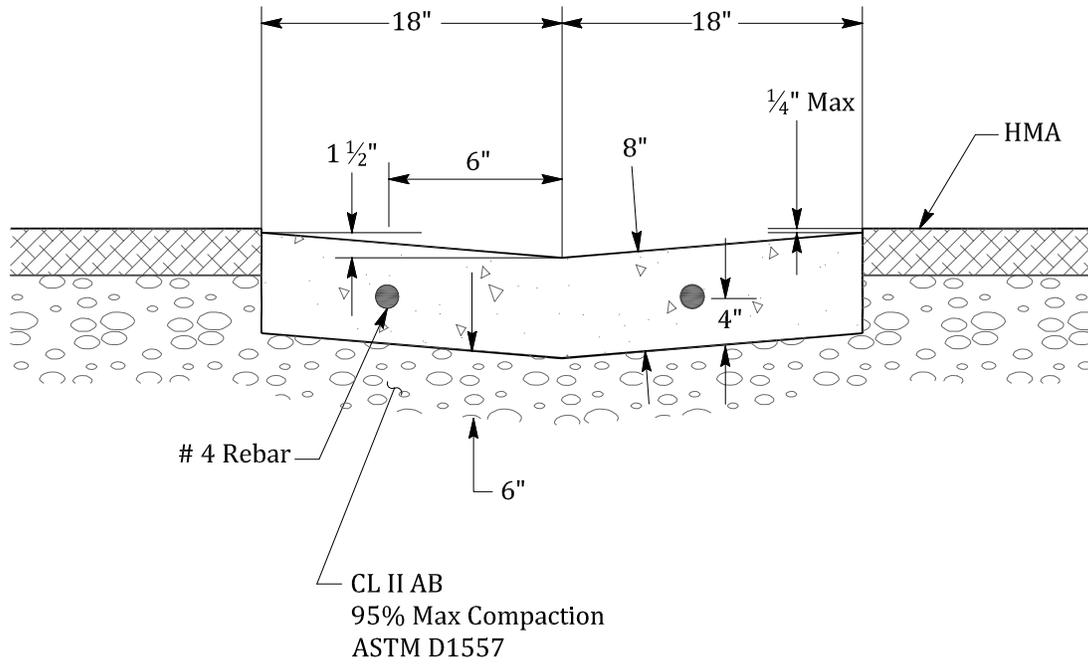

**NOTES:**

1. Expansion Joints with 1/2" x 12" slip.
2. Dowels at 20 foot intervals.
3. All concrete shall be per current Caltrans Specifications Section 73 "Concrete Curbs and Sidewalks" and Section 90 "Concrete". Concrete shall include two (2) pounds of liquid lamp black per cubic yard of concrete. Liquid lamp black color shall be "Davis A 8090 Black" or equal.

NOT TO SCALE

APPROVED BY	DATE		<b>CONCRETE VALLEY GUTTER</b>	STD. PLAN NO.
 CITY ENGINEER	APRIL 2017 Rev. 4/19/17			<b>SD-02</b>

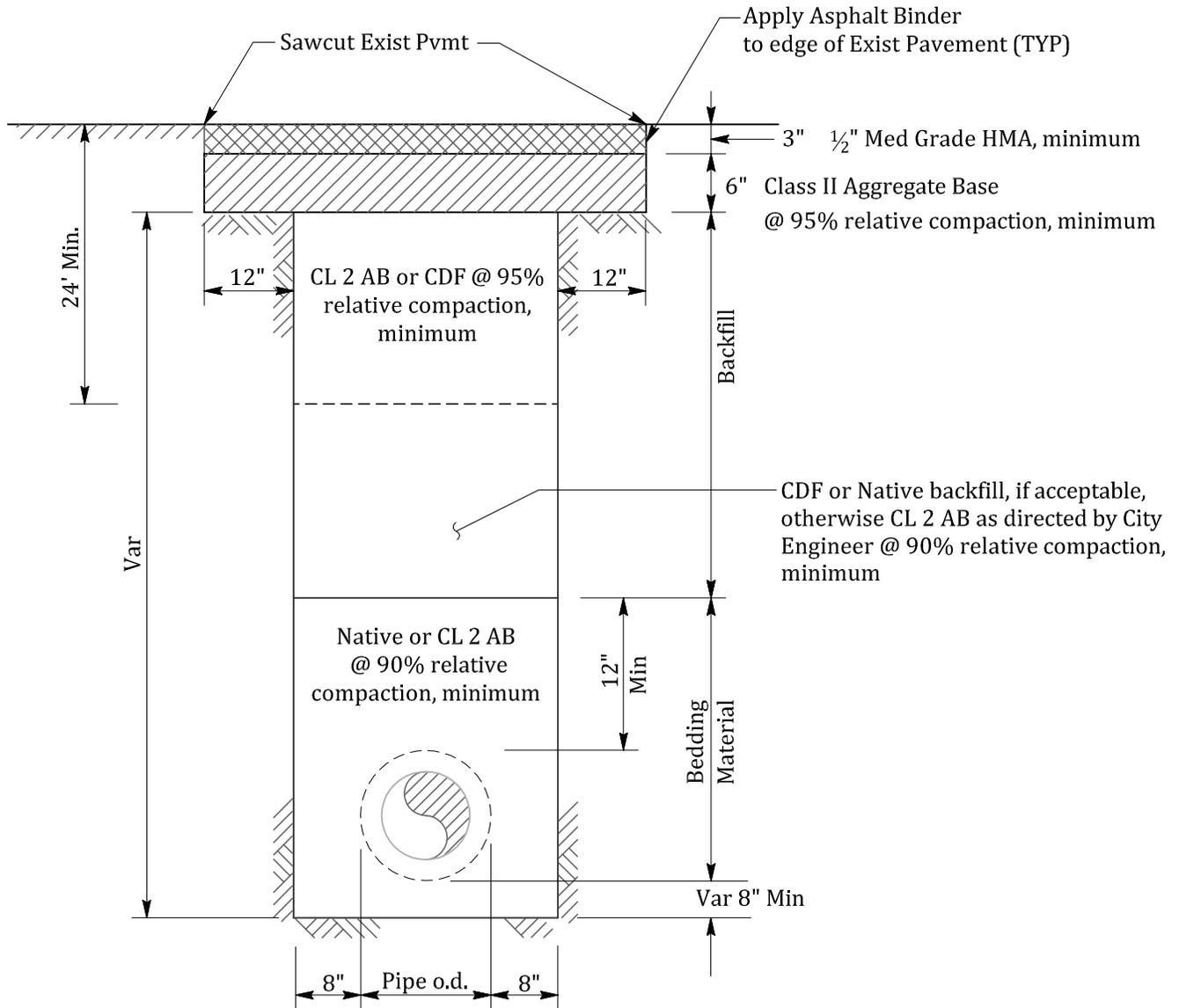

**NOTE:**

See Standard Plan SD-04 for additional trench requirements.

The 3" HMA shall be placed in two 1.5" lifts.

NOT TO SCALE

APPROVED BY	DATE		<b>PIPE TRENCH DETAIL</b>	STD. PLAN NO.
 CITY ENGINEER	JUNE 2016			SD-03
	rev 12/7/17			



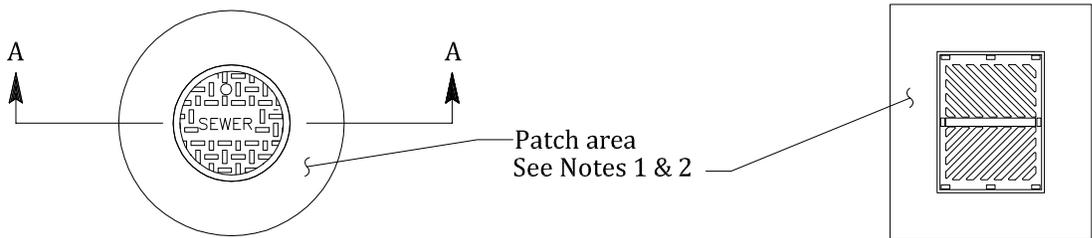

**PLAN**

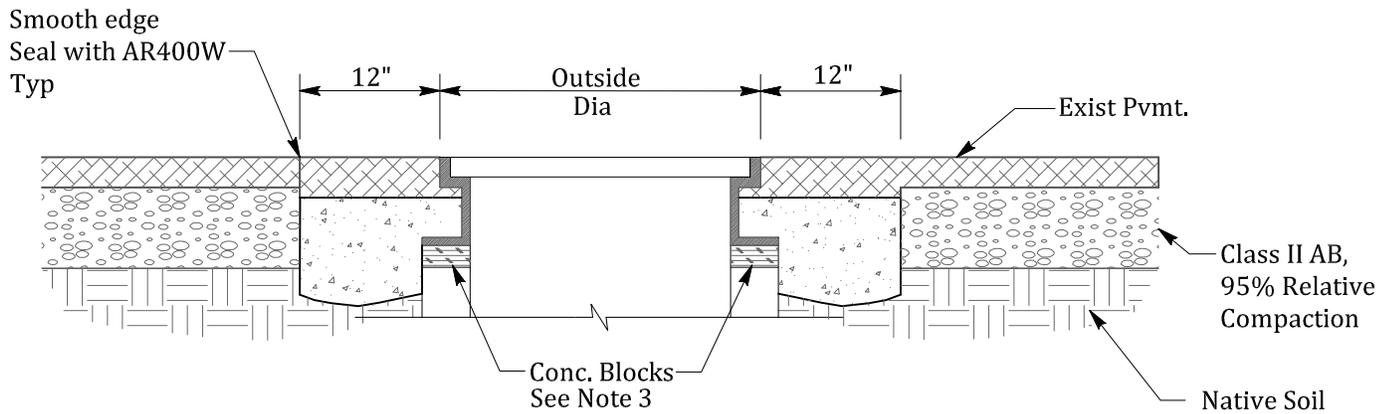

**SECTION A-A**

### **MANHOLE & CATCH BASIN ADJUSTMENT**

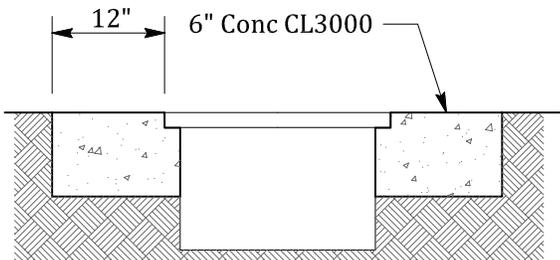

**OUTSIDE PAVED AREA**

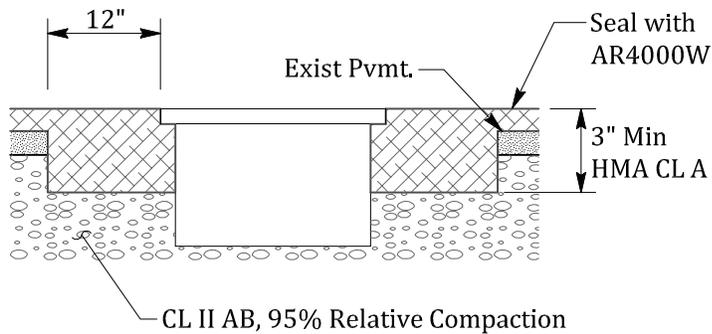

**INSIDE PAVED AREA**

### **VALVE BOX ADJUSTMENT**

**NOTES:**

1. Remove pavement and base materials for a distance which is equal to the diameter of the frame plus two (2) feet. Adjust casting frame to new pavement surface using concrete blocks.
2. Asphalt concrete Class "B" (3" Min) replacement patch to be 1" thicker than previously existed. The rest of the backfill to be controlled density fill.
3. 2" x 4" x 8" solid brick used for final adjustment to grade. 6" high Maximum.

NOT TO SCALE

<b>APPROVED BY</b>	<b>DATE</b>		<b>MANHOLE/CATCH BASIN &amp; VALVE BOX ADJUSTMENT</b>	<b>STD. PLAN NO.</b>
	JUNE 2016			SD-05
<b>CITY ENGINEER</b>				





Bicycle Safe Grate  
 Frame and Grate  
 2" x 3/16" Reticuline  
 Bars Typ See  
 Std Plan SD-11

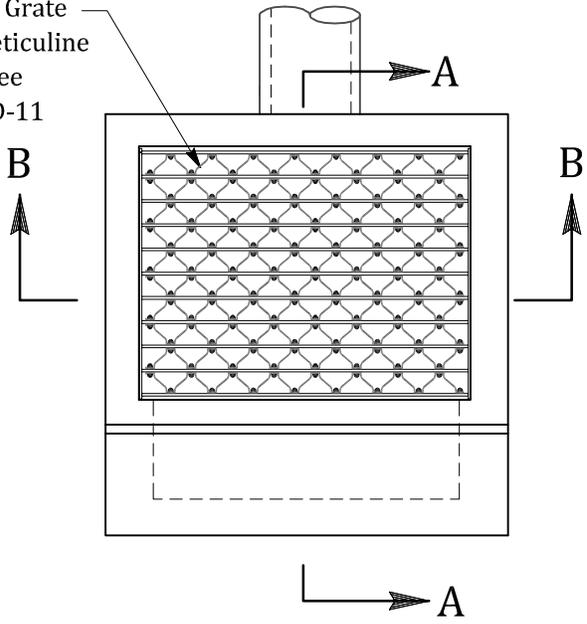

PLAN

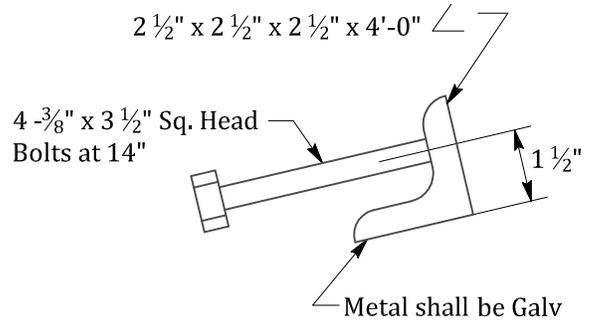

ANGLE ANCHOR

NOTE:

Where Inlet is located within a return, angle anchor shall be curved to match face of curb radius.

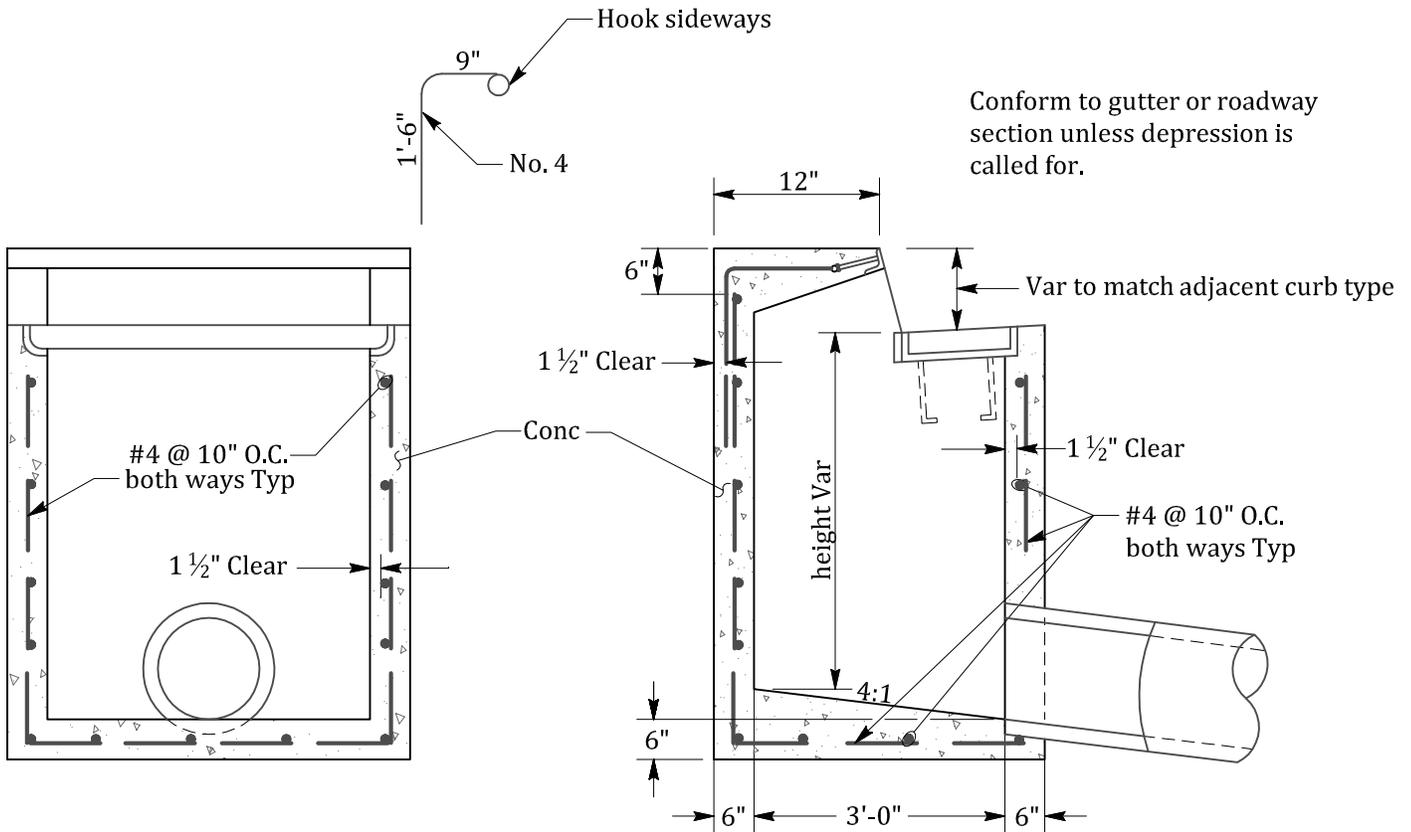

SECTION B - B

SECTION A - A

NOT TO SCALE

APPROVED BY	DATE		<b>TYPE I CURB          INLET</b>	STD. PLAN NO.
	JUNE 2016			SD-08
CITY ENGINEER				

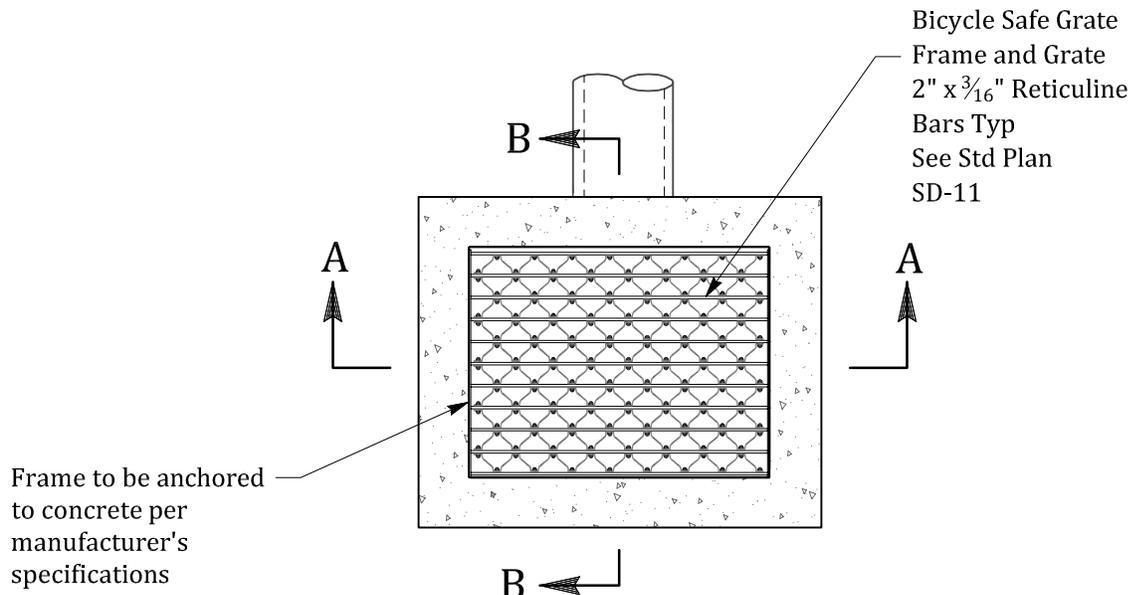

PLAN

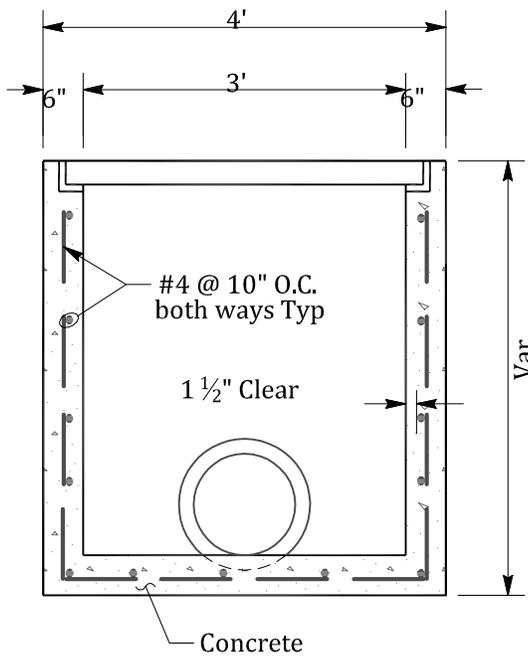

SECTION A-A

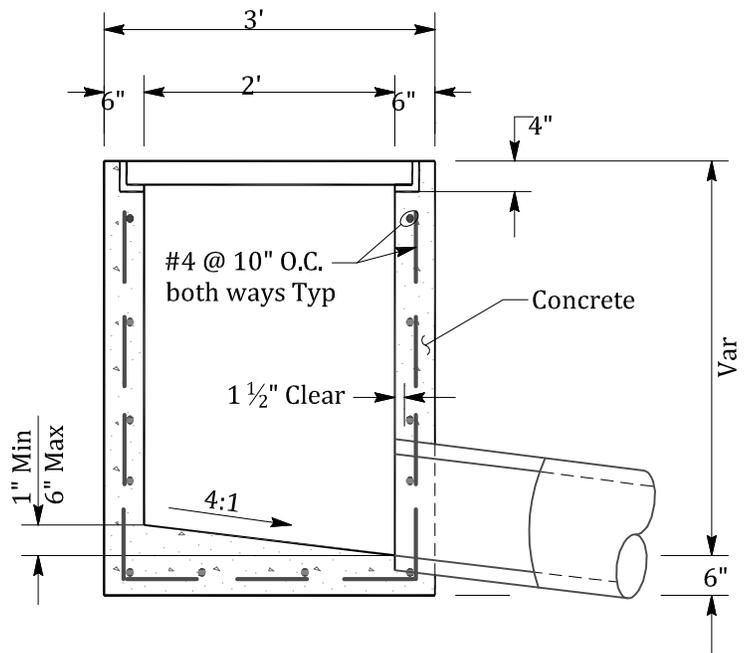

SECTION B-B

NOT TO SCALE

APPROVED BY	DATE		TYPE II INLET	STD. PLAN NO.
<i>Kevin Rohan</i>	JUNE 2016			SD-09
CITY ENGINEER				

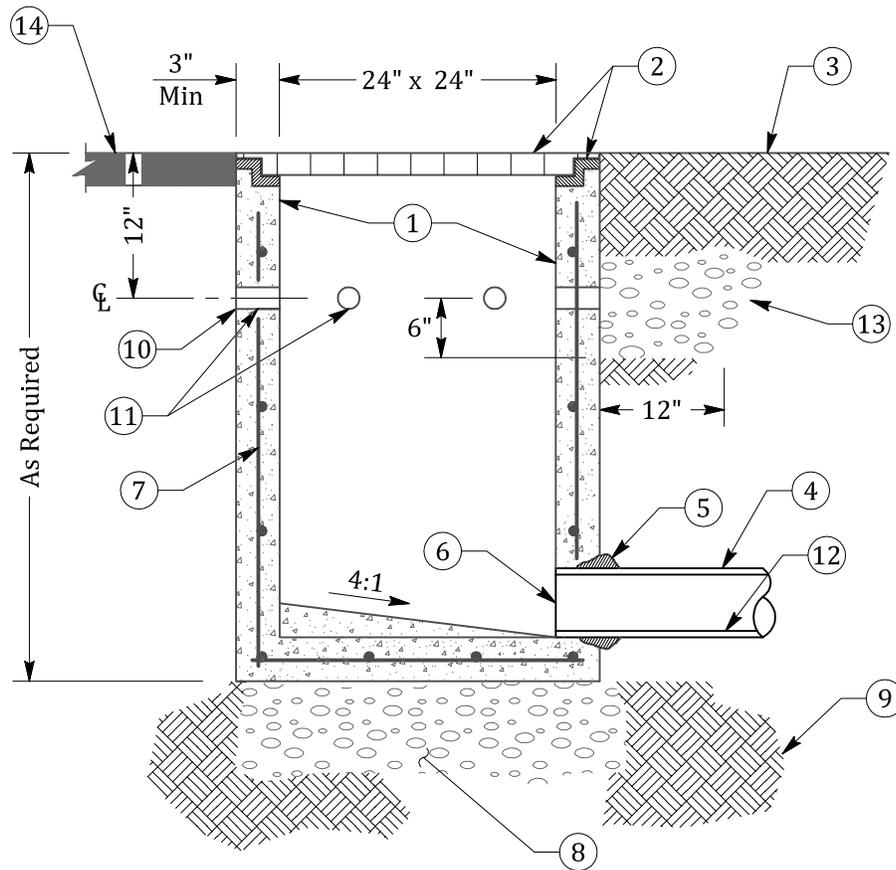

**BASIN DETAIL**

**LEGEND:**

- |   |  |
|---|--|
| ① Precast concrete basin, per plan.   | ⑨ Subgrade, compacted to 90% relative density.   |
| ② Grate and frame, w/grate locking device, per plan.                                | ⑩ At planting areas, 18" wide filter fabric wrapped around & glued at edges to structure where weep holes occur. |
| ③ Finish grade, flush with top of grate   | ⑪ At planting areas, 2" weep holes at 10" O.C.   |
| ④ Storm drain pipe, per plan.   | ⑫ Invert elevation, per plan.  |
| ⑤ Grout pipe in place.  | ⑬ Where weep holes occur surround catch basin with drain rock, 3/4" Diameter Max size, compacted.                |
| ⑥ Pipe openings to be cast into concrete.   | ⑭ Finish surface, where paving occurs.   |
| ⑦ Reinforcement per Manufacturer.   |  |
| ⑧ Aggregate base, Class II, 9" deep x basin width. Compact to 95% relative density. |  |

NOT TO SCALE

APPROVED BY	DATE		TYPE III LANDSCAPE AREA INLET	STD. PLAN NO.
 CITY ENGINEER	JUNE 2016			SD-10

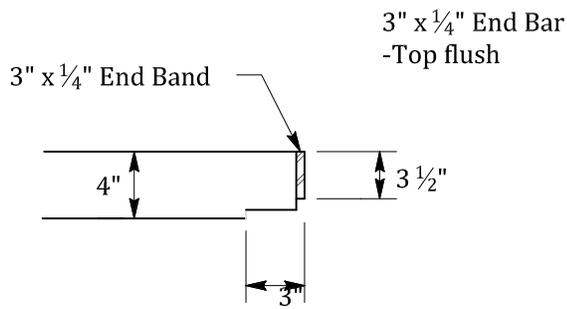

SECTION A - A

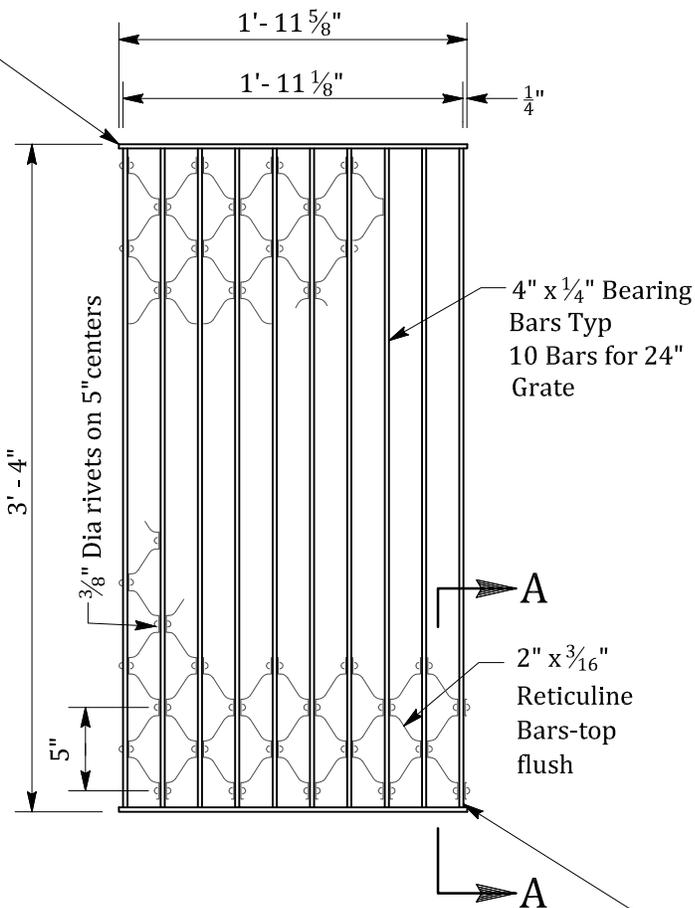

$\frac{3}{16}$ " Fillet weld full depth each side  
On the outside Bearing Bar and  
every other internal Bar.

GRATE

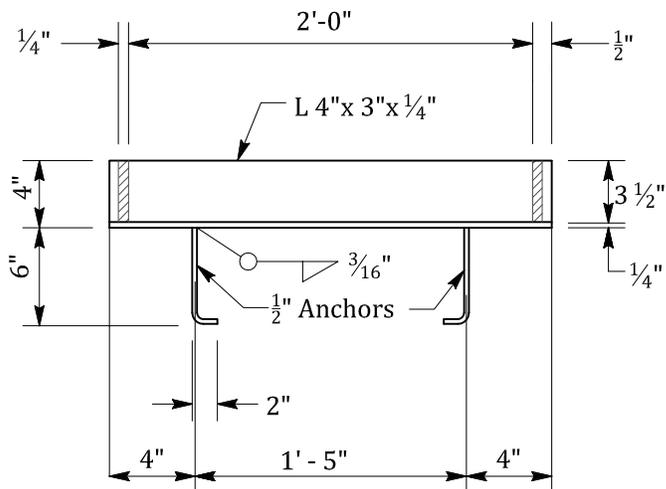

SECTION B - B

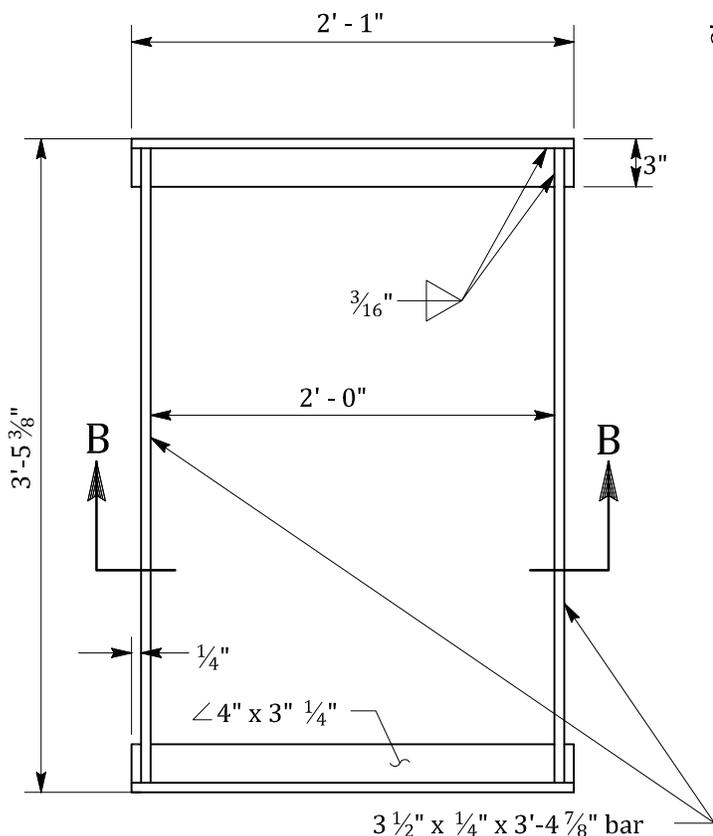

FRAME

NOTES:

1. Hinged Grate only when specified.
2. Place Grate Bars parallel to flow.
3. Frame, Grate, and Anchors shall be galvanized after fabrication.
4. Frame and Grate to be welded steel or approved alternative.

NOT TO SCALE

APPROVED BY	DATE		<b>RETICULINE FRAME &amp; GRATE</b>	STD. PLAN NO.
	JUNE 2016			SD-11
CITY ENGINEER				

4"

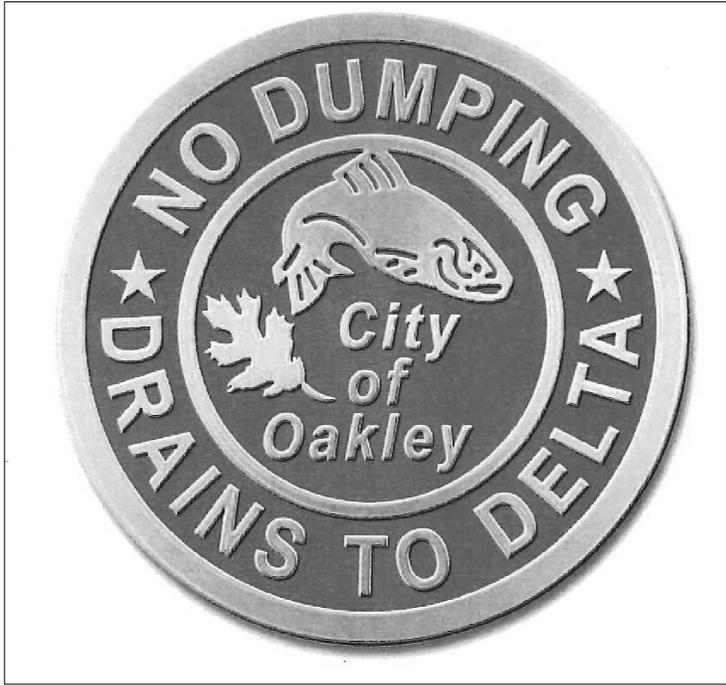

TOP VIEW

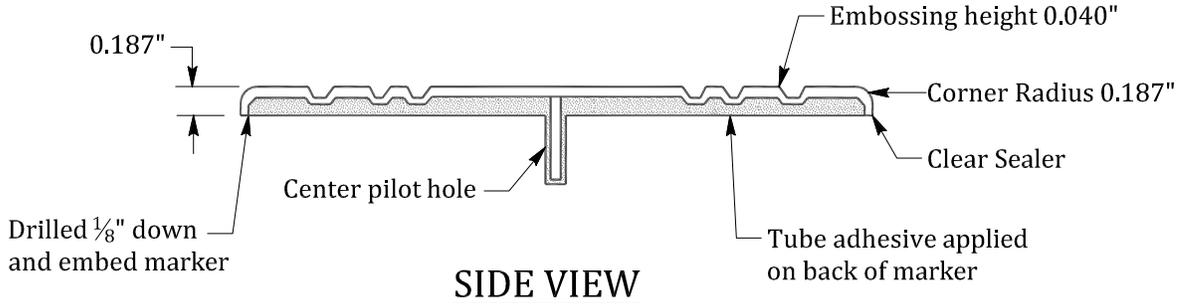

SIDE VIEW

NOTES:

1. Available for purchase at the City of Oakley Public Works Department.
2. Storm Drain marker by Almetek, Item No. STDN-9599-SSP.
3. Sub-surface installation with tube adhesive.
4. Wire brush surface, blow dust, apply adhesive press down.

Hardware:

- SIKS-ADH  
Sikaflex 10.1 fl. oz. caulk tube  
(1 Tube per 15 markers)
- CDB4  
Carbide Drill Bit
- DCG  
Dripless caulking gun

NOT TO SCALE

<p>APPROVED BY</p> <p>CITY ENGINEER</p>	<p>DATE</p> <p>JUNE 2016</p>		<h2>STORM DRAIN MARKER</h2>	<p>STD. PLAN NO.</p> <p>SD-12</p>
---	------------------------------	--	---------------------------------	-----------------------------------

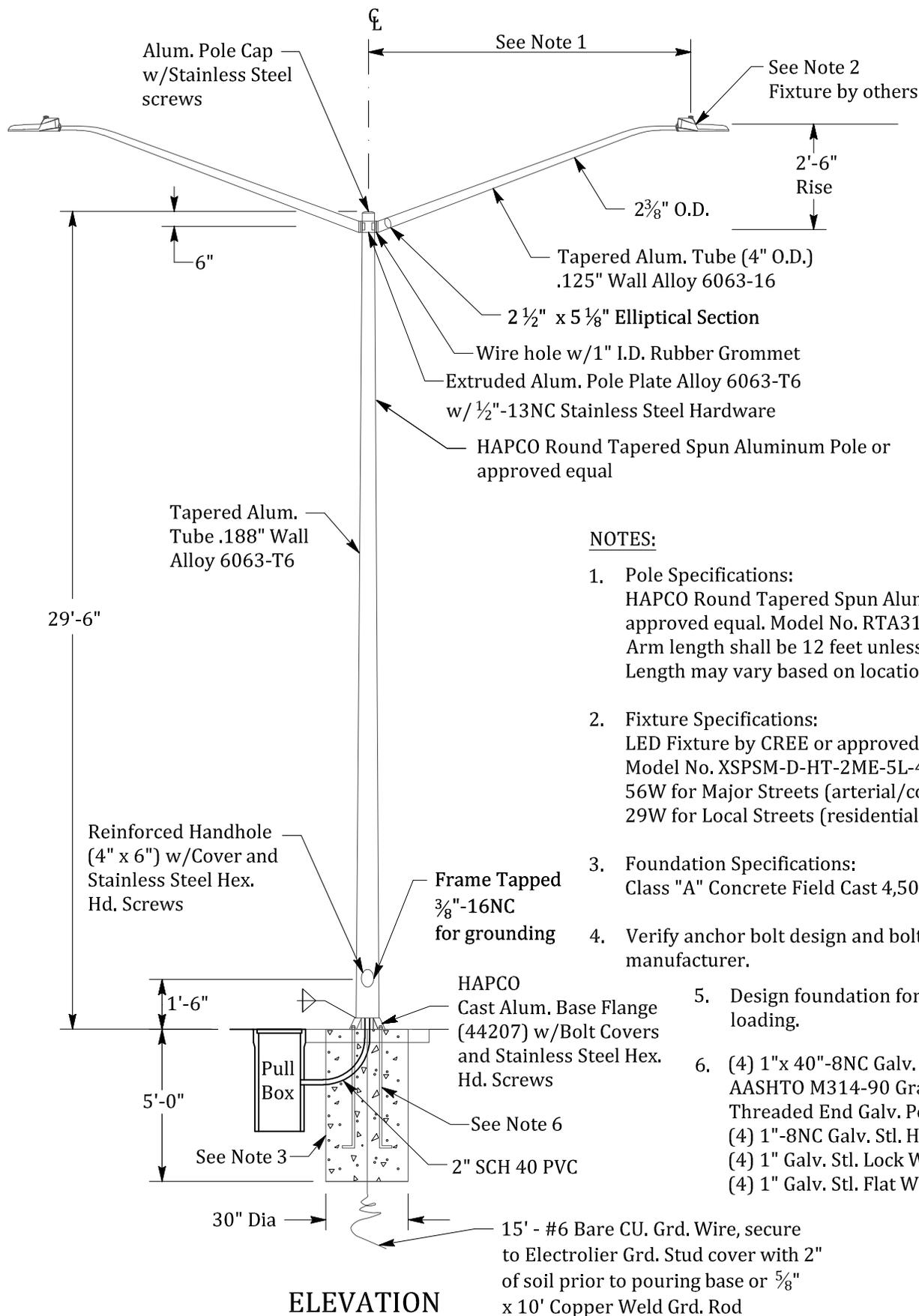

**NOTES:**

- 1. Pole Specifications:  
HAPCO Round Tapered Spun Aluminum Pole or approved equal. Model No. RTA316D8C4M2C-01 Arm length shall be 12 feet unless noted on the plans. Length may vary based on location and street type.
- 2. Fixture Specifications:  
LED Fixture by CREE or approved equal. Model No. XSPSM-D-HT-2ME-5L-40K7-UL-SV-N-Q7 56W for Major Streets (arterial/collector) 29W for Local Streets (residential)
- 3. Foundation Specifications:  
Class "A" Concrete Field Cast 4,500 PSI minimum.
- 4. Verify anchor bolt design and bolt circle with manufacturer.
- 5. Design foundation for 100 mph wind loading.
- 6. (4) 1"x 40"-8NC Galv. Stl. Anchor Bolts, AASHTO M314-90 Grade 55, 10" Of Threaded End Galv. Per ASTM A153. (4) 1"-8NC Galv. Stl. Hex. Nuts (4) 1" Galv. Stl. Lock Washers (4) 1" Galv. Stl. Flat Washers

**ELEVATION**

NOT TO SCALE

APPROVED BY	DATE		<b>STREET LIGHT COBRA HEAD DOUBLE L.E.D.</b>	STD. PLAN NO.
	JUNE 2016			E-01
CITY ENGINEER	rev 3/9/20			

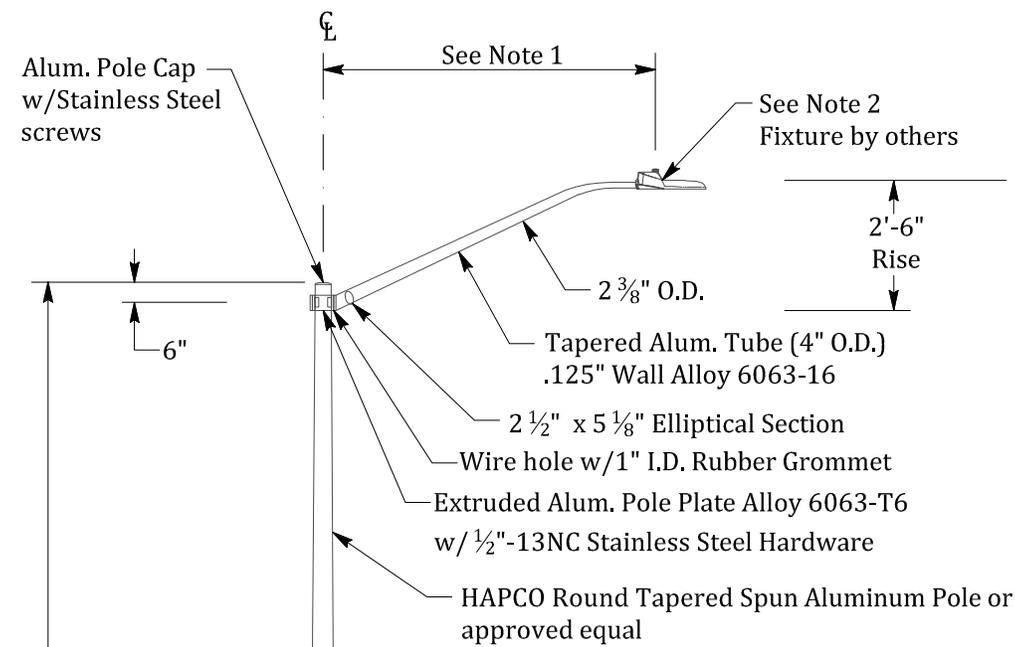

29'-6"

5'-0"

1'-6"

30" Dia

**ELEVATION**

**NOTES:**

1. Pole Specifications:  
HAPCO Round Tapered Spun Aluminum Pole or approved equal. Model No. RTA316D8C4M1C-01  
Arm length shall be 12 feet unless noted on the plans.  
Length may vary based on location and street type.
2. Fixture Specifications:  
LED Fixture by CREE or approved equal.  
Model No. XSPSM-D-HT-2ME-5L-40K7-UL-SV-N-Q7  
56W for Major Streets (arterial/collector)  
29W for Local Streets (residential)
3. Foundation Specifications:  
Class "A" Concrete Field Cast 4,500 PSI minimum.
4. Verify anchor bolt design and bolt circle with manufacturer.
5. Design foundation for 100 mph wind loading.
6. (4) 1" x 40"-8NC Galv. Stl. Anchor Bolts, AASHTO M314-90 Grade 55, 10" Of Threaded End Galv. Per ASTM A153.  
(4) 1"-8NC Galv. Stl. Hex. Nuts  
(4) 1" Galv. Stl. Lock Washers  
(4) 1" Galv. Stl. Flat Washers

**NOT TO SCALE**

APPROVED BY	DATE		<b>STREET LIGHT COBRA HEAD SINGLE L.E.D.</b>	STD. PLAN NO.
	JUNE 2016			<b>E-02</b>
CITY ENGINEER	rev 3/9/20			

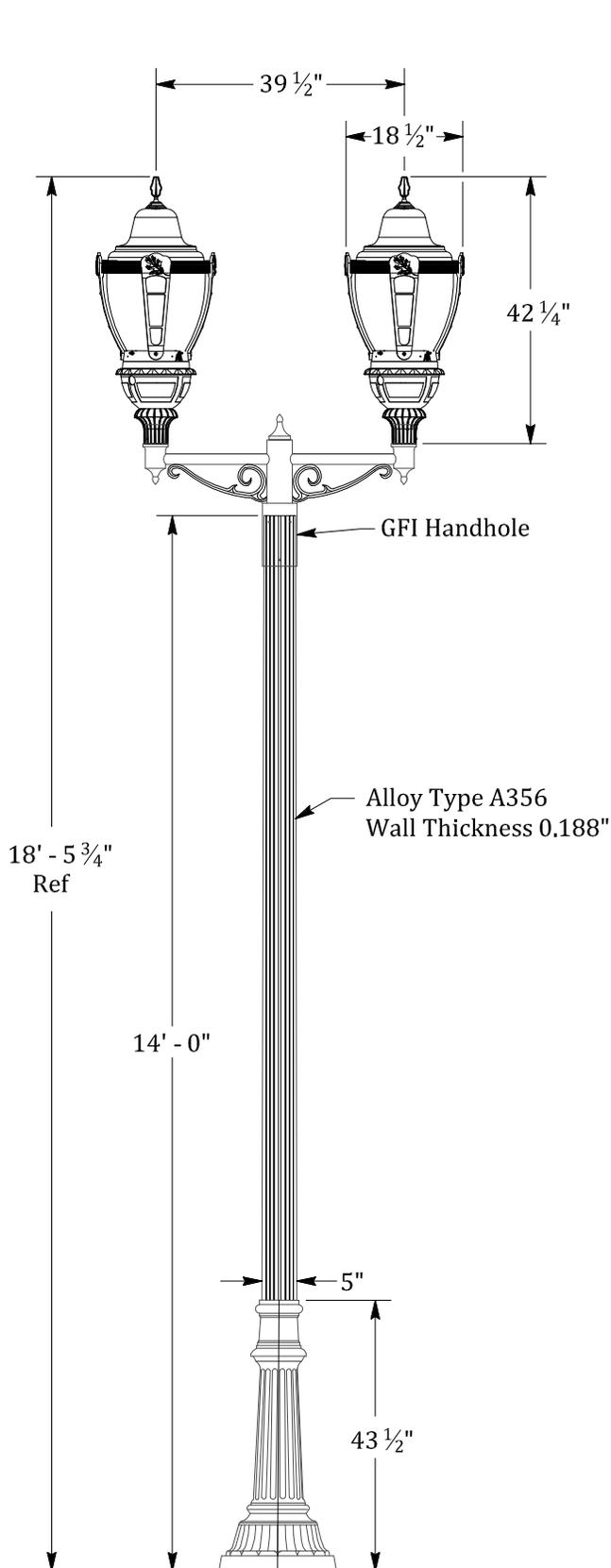

**ELEVATION**

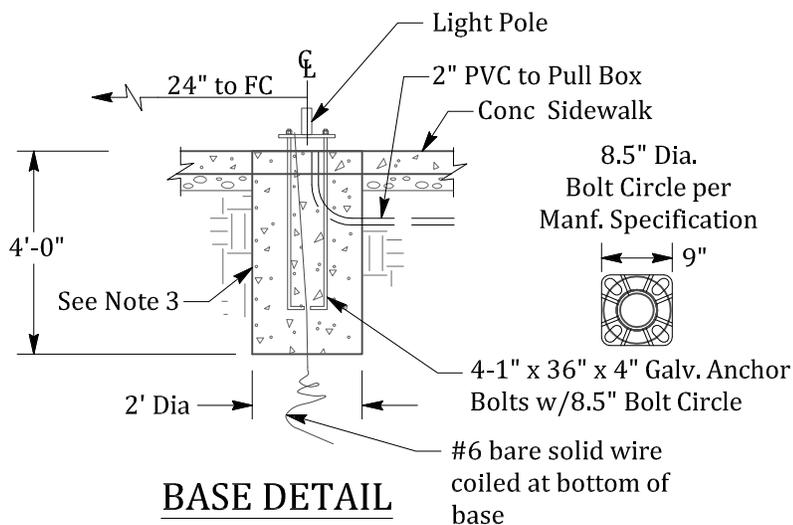

**BASE DETAIL**

**NOTES:**

1. Pole Specifications:  
 BEACON Pole Model No. RSA-B-SHO-F-14-50-B-OT-BBT +  
 VINYL/5/BBT w/clam shell base

Pole shall be factory prime coated and electrostatically powdered coated "Black" with the allocation of a 3.5-mil weather resistant powder coat whose base is polyester and thermocured. Base painted both inside and out.

2. Fixture Specifications:  
 BEACON  
 (2) Model No. T1/AF/C3 MOD/H2/24NB-  
 55/4K/UNV/DIR3 or  
 DIR4/PCR-TL-7P/BBT+AA-52/5/C/T/FINIAL/BBT

Lens: Acrylic, Frosted  
 Optics: Type III (residential street)  
 Type IV (cul de sac)

Light: 24 LED Engine and Drivers Combination  
 Voltage: 120 Through 277 Volts, 60Hz

Fixture shall be SiteSync ready to include plug in daughter board or approved equal

Fixture shall be NRTL Listed for Wet Location.  
 Fasteners shall be stainless steel.

3. Foundation Specifications:  
 Class "A" Concrete Field Cast 2,500 PSI minimum @ 28 Days.
4. Verify anchor bolt design and bolt circle with manufacturer.
5. Design foundation for 100 mph wind loading.
6. Decorative light pole bases shall be provided at the sole cost of Developer or Contractor, with the authorization of the City.
7. Conduit shall be installed with 30" of cover.
8. Contact Oakley Beacon Manufacturer Representative  
 (530) 888-8686.

NOT TO SCALE

APPROVED BY	DATE		<b>STREET LIGHT          DECORATIVE          DOUBLE L.E.D.</b>	STD. PLAN NO.
	JUNE 2016			<b>E-03</b>
CITY ENGINEER	Rev. 5/8/17			

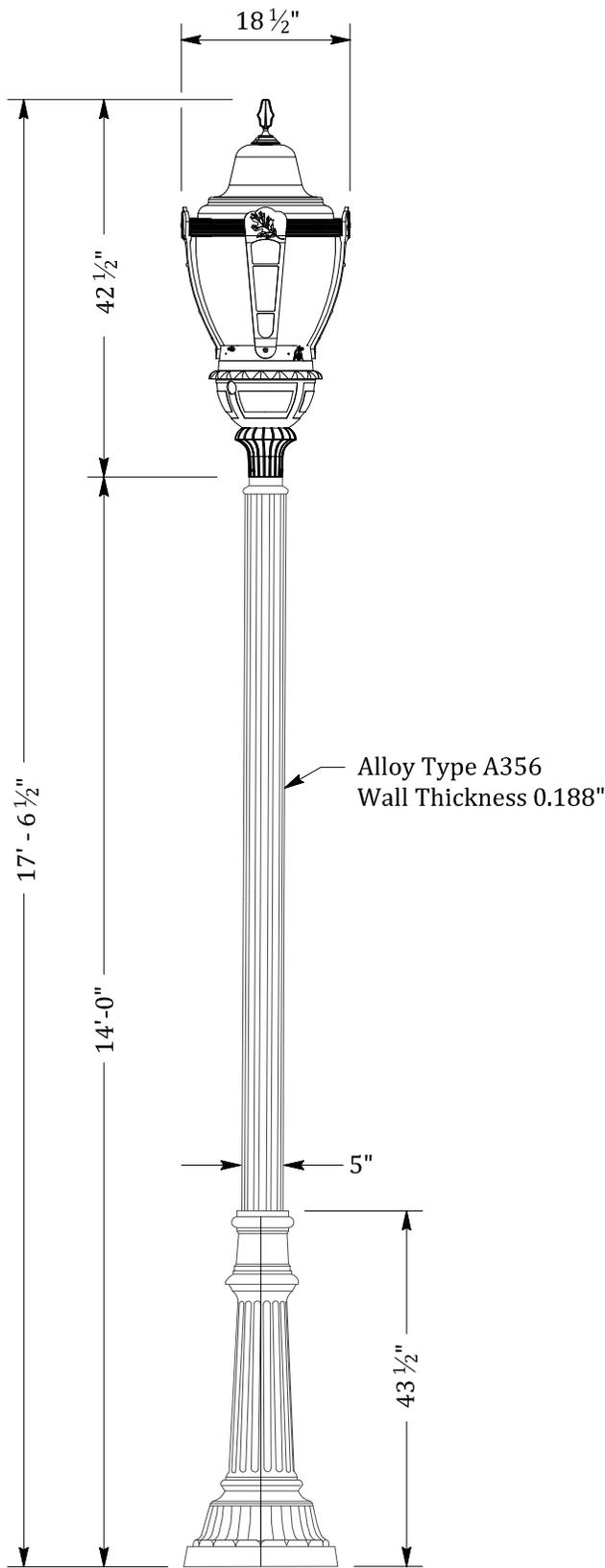

**ELEVATION**

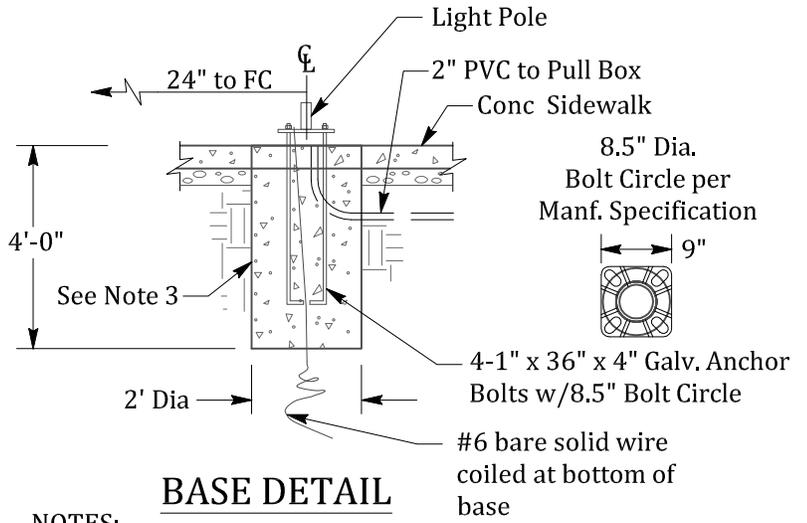

**BASE DETAIL**

**NOTES:**

1. Pole Specifications:  
 BEACON Pole Model No. RSA-B-SHO-F-14-50-B-OT-BBT + VINY/5/BBT w/clam shell base  
  
 Pole shall be factory prime coated and electrostatically powdered coated "Black" with the allocation of a 3.5-mil weather resistant powder coat whose base is polyester and thermocured. Base painted both inside and out.
2. Fixture Specifications:  
 BEACON  
 Model No. T1/AF/C3 MOD/H2/24NB-55/4K/UNV/DIR3 or DIR4/PCR-TL-7P/BBT  
  
 Lens: Acrylic, Frosted  
 Optics: Type III (residential street)  
           Type IV (cul de sac)  
  
 Light: 24 LED Engine and Drivers Combination  
 Voltage: 120 Through 277 Volts, 60Hz  
  
 Fixture shall be NRTL Listed for Wet Location.  
 Fasteners shall be stainless steel and meet AAMA 605.2 performance specification
3. Foundation Specifications:  
 Class "A" Concrete Field Cast 2,500 PSI minimum @ 28 Days.
4. Verify anchor bolt design and bolt circle with manufacturer.
5. Design foundation for 100 mph wind loading.
6. Decorative light pole bases shall be provided at the sole cost of Developer or Contractor, with the authorization of the City.
7. Conduit shall be installed with 30" of cover.
8. Contact Oakley Beacon Manufacturer Representative  
 (530) 888-8686

**NOT TO SCALE**

APPROVED BY	DATE		<b>STREET LIGHT          DECORATIVE          SINGLE L.E.D.</b>	STD. PLAN NO.
<i>Kevin Rohan</i>	JUNE 2016			E-04
CITY ENGINEER	Rev. 5/8/17			





ALL DIMENSIONS ARE IN INCHES

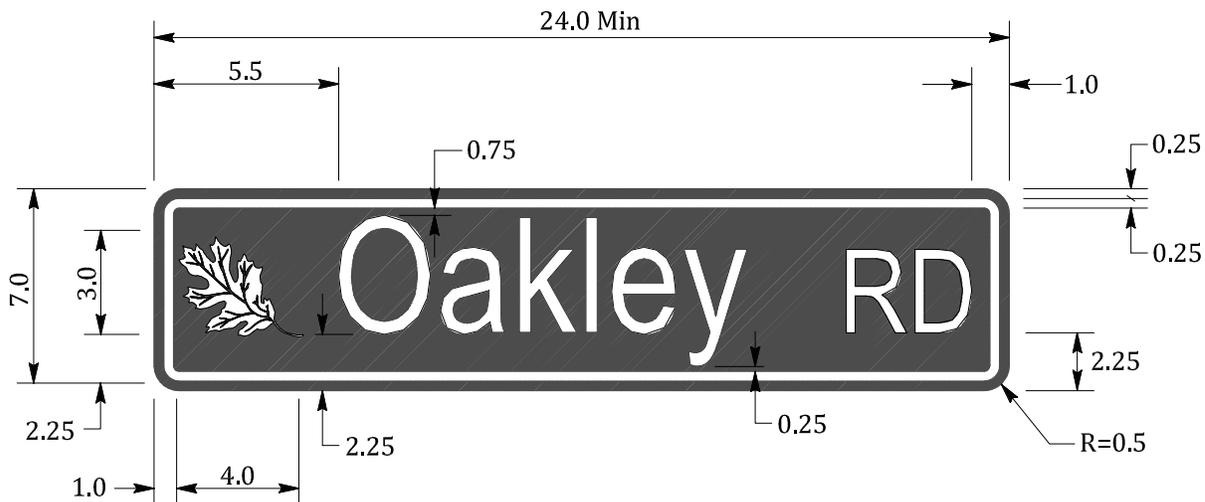

### DETAIL

#### ACCEPTABLE SIGN ABBREVIATION

AVE	Avenue	PL	Place
BLVD	Boulevard	RD	Road
CIR	Circle	ST	Street
CT	Court	TER	Terrace
DR	Drive	PKWY	Parkway
LN	Lane	PVT	Private

#### NOTES:

1. A combination of 4" "Highway Gothic" Font (UC) with 3" "Highway Gothic" Font (LC) shall be used on low-volume roads and on urban street with speeds of 25 MPH.
2. Supplementary lettering to indicate the type of street (such as Street, Avenue, or Road) shall be in smaller lettering 3" high.
3. The border shall be 0.25-inch in width. The corners of the sign should be rounded to fit the border.
4. Street name sign blanks shall be 0.125 inch thick, ASTM B209 Alloy 6061-T6, flat aluminum.
5. Reflective sheeting shall be 3M Visual Impact Performance - Series 3990 (green and white) and shall be coated with 3M Premium Protective Overlay Film - Series 1160 (both sides), or approved equivalents.
6. Sign colors shall be a green background with white letters and white border.
7. Signs shall be double faced (front and rear)
8. Sign location and mounting shall be as shown on location detail (SS-03) Sheet 3.
9. At the intersection with public street/private street name sign shall match the Standard Drawings but must have "PVT" where the block would go.

**NOT TO SCALE**

APPROVED BY	DATE	OAKLEY CALIFORNIA	STREET NAME SIGN MINOR STREET	STD. PLAN NO.
<i>Kevin Robain</i>	JUNE 2016			SS-02
CITY ENGINEER				

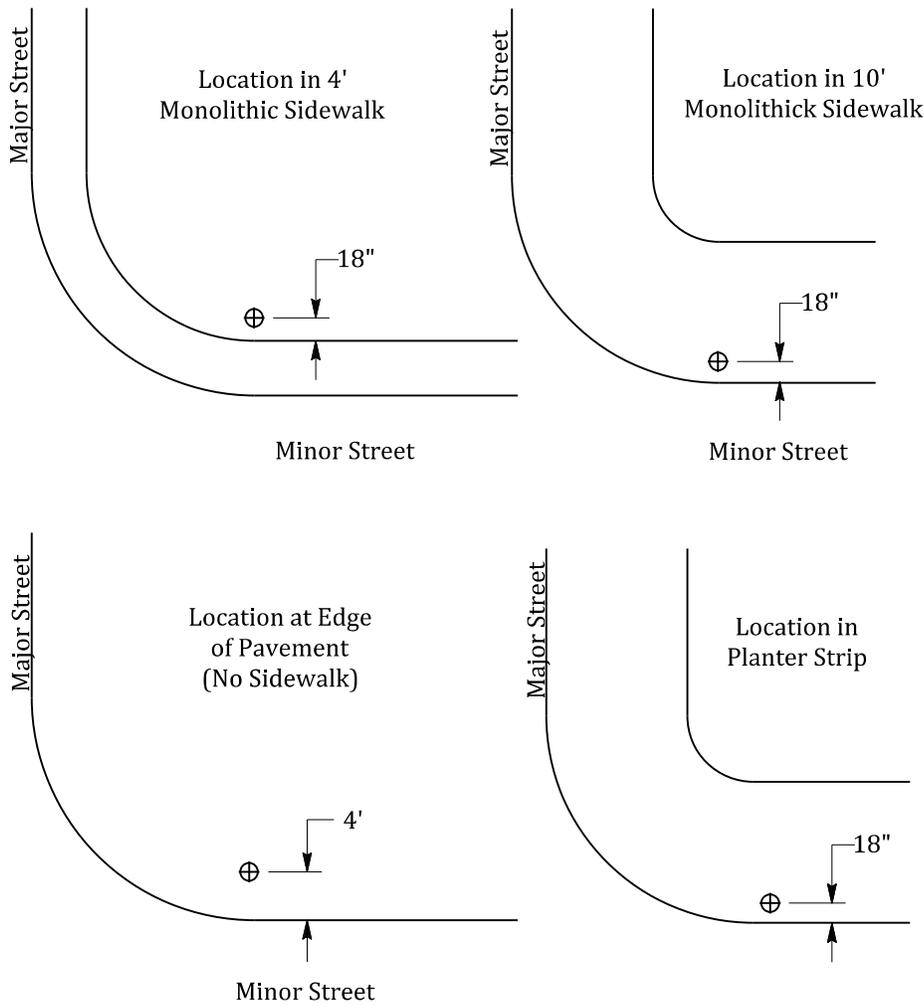

SIGN LOCATIONS

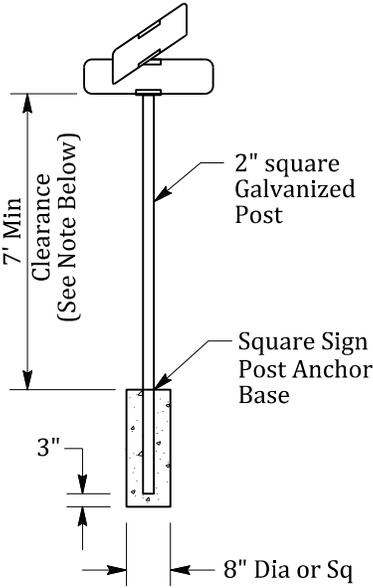

**DETAIL "A"**  
(Typical)

**NOTE:**  
Stop signs mounted on same post as street name signs shall be below street name signs. (See Note 6)

**NOTES:**

1. Sign to be located 18 inches from face of curb or back of 4' monolithic sidewalk.
2. Bottom of sign shall be mounted 7 feet Min above ground or sidewalk per Detail "A" shown on this sheet.
3. Signs to be City of Oakley Standard Street Name Sign.
4. Signs shall be mounted with Hawkins' Heavy Duty Aluminum "Vandal Proof" (HD) VP Model #V14F-(HD)VP-2C2P (without finial) or approved equal.
5. Signs mounted on signal standards or electroliers shall be mounted with Hawkins' "Vandal Proof" wing bracket Model #V14F-(HD) VP-AB or approved equal. Brackets shall be fastened to poles with two (2) 3/4" wide x 0.030" thick Type 201 Stainless Steel bends.
6. Street name sign may be combined with stop sign (R1), and placed in a location for maximum visibility as approved by the City Engineer.

**NOT TO SCALE**

APPROVED BY	DATE		<b>STREET NAME SIGN LOCATION AND MOUNTING</b>	STD. PLAN NO.
 CITY ENGINEER	JUNE 2016			SS-03



## TREE SPECIFICATIONS

All trees must meet the following minimum specifications:

1. HEIGHT: 7 - 8 feet high planted in the ground.
2. CALIPER: 1 ½ inches, measured 6 inches from the base (24 inch Box Minimum).
3. BRANCHING NEED: Minimum spread of 2 - 3 feet with good branch distribution
4. CENTRAL LEADER: Single, relatively straight

Any exception to the above must be approved by the City.

All planting stock must have the approval of the City.

City reserves the right to reject trees that do not meet high quality nursery stock of the current edition of the Guideline Specifications for Nursery Tree Quality, published by the Urban Tree Foundation

## PLANTING SEQUENCE

1. Dig the planting hole as deep as the container and twice as large as its diameter
2. Remove the root ball carefully from the container by supporting it from below. Sever any circling roots ( $\frac{3}{16}$  inch or greater) with sharp shears or knife. If the root ball is dense or compacted, carefully loosen the roots at the side and bottom of the root ball. Do not pull the root ball apart. The severing of large roots will encourage new roots initiating at the cuts.
3. Center root ball in hole on undisturbed soil such that root crown is visible at the top of the root ball and 2 inches above grade.
4. Fill planting hole around root ball with backfill mix and foot-tamp in lifts. Be careful not to disturb the root ball.
5. Backfill mix shall include U.C. Ag. mix or approved equivalent. U.C. Ag. mix shall be combined with existing soil,  $\frac{1}{3}$  mix,  $\frac{2}{3}$  native soil unless specified otherwise by the soils analysis.
6. Fertilizer and post-plant fertilizer shall be as required by soils analysis.
7. Use the remaining native soil to create a basin appropriate to the site.

APPROVED BY	DATE		<b>TREE PLANTING SPECIFICATIONS</b>	STD. PLAN NO.
 CITY ENGINEER	JUNE 2016			L-02

**NOTES:**

1. Avoid damage to roots.
2. Avoid root ball when placing stakes.
3. Root barrier required for trees 6' or less from paving. Installed against paving per mfrs. specifications for a linear installation. Panel length per mfrs. specifications and extend a min. length of 10' from trunk.
4. Backfill mix and pst-plant fertilizer as required by soils analysis.

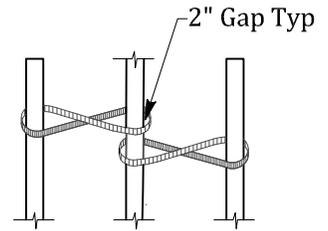

**DETAIL A**

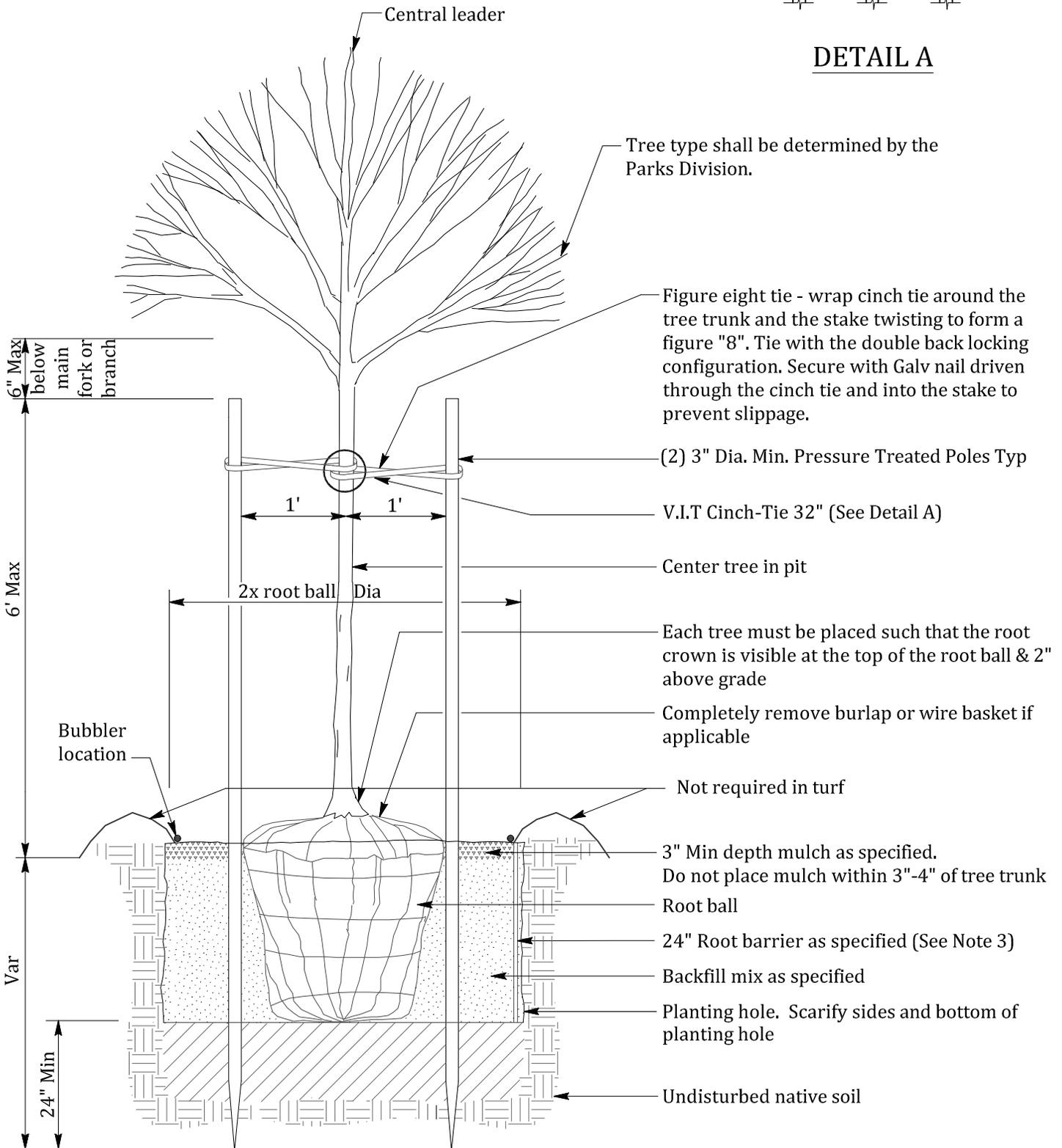

NOT TO SCALE

APPROVED BY	DATE		<b>TREE PLANTING</b>	STD. PLAN NO.
 CITY ENGINEER	JUNE 2016			<b>L-03</b>

NOTES:

- 1. Backfill mix and post-plant fertilizer as required by soils analysis.

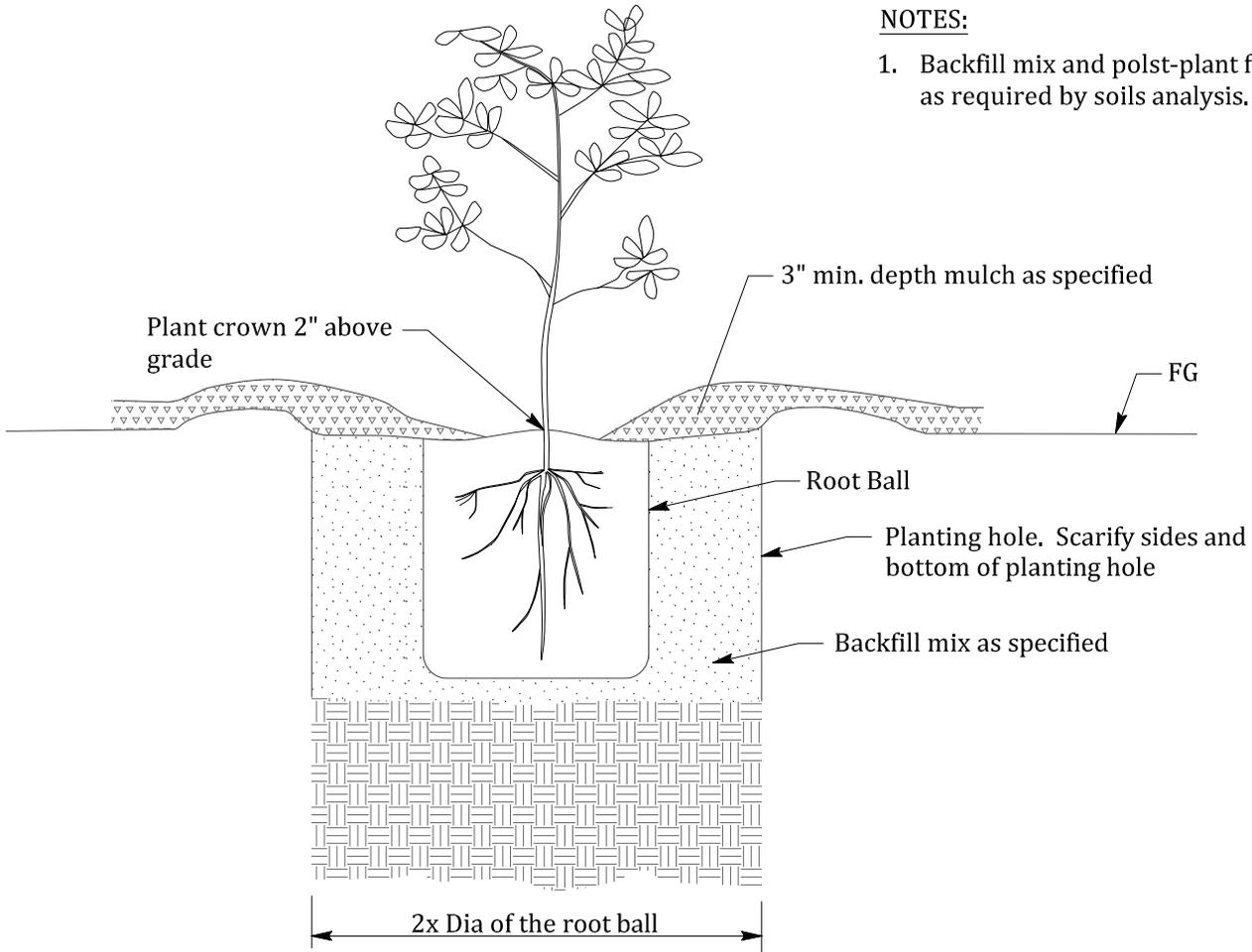

**SHRUB PLANTING DETAIL**

NOT TO SCALE

APPROVED BY	DATE		SHRUB PLANTING	STD. PLAN NO.
<i>Kevin Rohani</i>	JUNE 2016		<b>L-04</b>	
CITY ENGINEER				

## IRRIGATION EQUIPMENT LIST

ITEM	MANUFACTURER/MODEL (OR APPROVED EQUAL)
Backflow Preventer	Per Diablo Water District Specifications and Details
Gate Valve (3 inch and larger)	Nibco 619 RW-SON
Gate Valve (2 ½ inch and smaller)	Nibco T113-K
Ball Valve	Nibco T-FP-600a Full Port Brass or KBI SCH 80 PVC True Union Type
Quick Coupling Valve	44 IRC or 44 NP (for Non-Potable)
Pressure Reducing Valve	Wilkins 500HLR Series
Master Valve	Included with Controller Assembly (See Note 1 below)
Flow Sensor	Included with Controller Assembly (See Note 1 below)
Remote Control Valve	Rainbird PESB or PESB-R (for non-potable), PRS-D Pressure Regulator option
Valve Boxes with Stainless Steel Lock-Down Bolts	Carson Trusst black colored box and lid for t- cover planters, green colored box and t-cover for turf areas. Carson Specification Grade.
Gate & Quick Coupling Valve Box with Stainless Steel Lock-Down Bolts	Carson Trusst Round black colored box and t- cover lid for planters, green colored box and t-cover lid for turf areas. Carson Specification Grade.
Controller Assembly	Rain Master Evolution DX II with SiteOne Satellite Assembly (See Note 1 Below)
Backflow Enclosure	Per Diablo Water District Specifications and Details
Backflow Preventer Freeze Protection	Per Diablo Water District Specifications and Details
Pop-Up Stream Rotor	Rainbird 1800 Series (PRS-SAM) with Hunter MP Rotator Nozzles
Gear Driven Rotor	Rainbird 5000 Series Hunter PGP
Pop-Up Spray	Rainbird 1800 Series (SAM-PRS)
Bubbler	Rainbird 1400 Series
Tree Bubbler	Rainbird RWS-B Series
Sub-Surface Irrigation	Rainbird XFS

**NOTES:**

1. SiteOne Satellite assembly with SA6-RM4-XX/FAN-16/RHG/RDM/PMR/FSAVC-XXX/RSE-DX/GRP-K/EV-CAB-SEN/  
EV-CAB-COM (if hardwiring DX2 controller together), Pro Max receiver, 1 Pro Max transmitter for every 5 assemblies,  
enclosure fan, housed in a top entry stainless steel enclosure, flow sensing assembly, with master valve, sensor cable, and  
rain sensor. Contact SiteOne Representative at (800)-SITE ONE for purchase order, pre-construction meeting, test for  
clear reception for radio communication with central computer, warranty, and certification. Contractor to verify power  
availability and install unit per manufacturers specifications on specified concrete pad.
2. All planters should be designed with a 100% bubbler based system (no drip or micro irrigation). Pop-Up rotators will  
be allowed in some instances (ground cover), but only on 5' or wider planters. Rotors are preferred for all turf areas.  
Where rotors are not feasible, pop-up rotators will be accepted as a substitute.

APPROVED BY	DATE		<b>IRRIGATION EQUIPMENT LIST</b>	STD. PLAN NO.
<i>Kevin Robani</i>	JUNE 2016			<b>IR-01</b>
CITY ENGINEER				

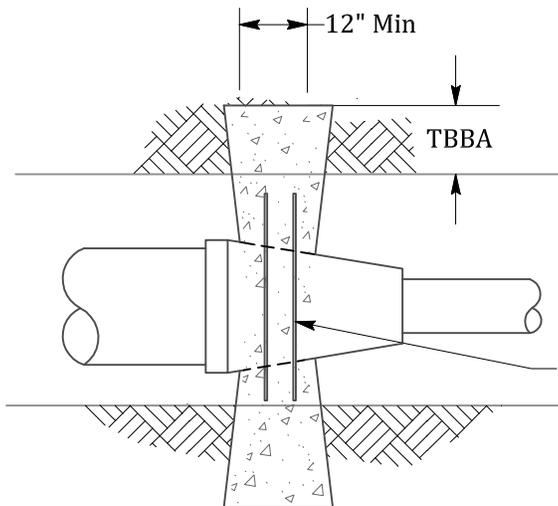

**REDUCERS**

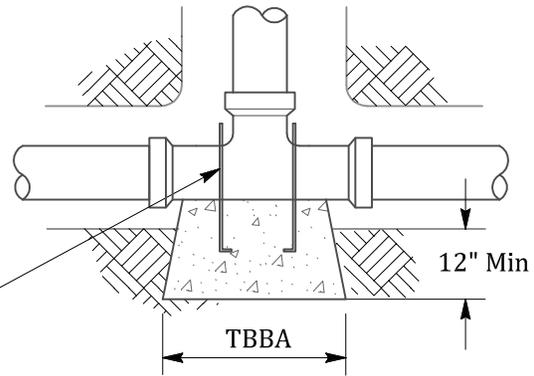

**TEES & DEAD ENDS**

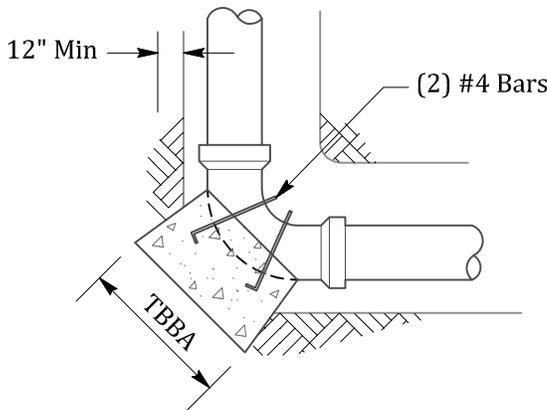

**ELBOWS**

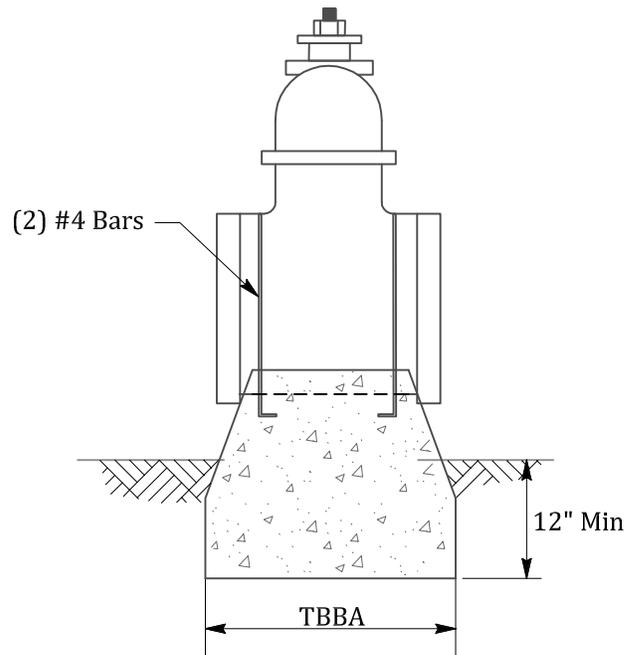

**VALVES**

**NOTES:**

- 1. Thrust blocks shall not project higher than 1/2 the distance from the bottom of the trench to finish grade. Place concrete against undisturbed soil.
- 2. Do not cover ends of fittings or bolts with concrete.
- 3. Concrete shall have compression strength of 2000 PSI.
- 4. Consult Manufacturer's literature for recommended thrust bearing area (TBBA) based on actual field conditions. At Minimum TBBA shall be sized as follows:

<u>PIPE SIZE</u>	<u>90-DEGREE ELLS</u>	<u>45-DEGREE ELLS</u>	<u>VALVES, TEES, REDUCERS, DEAD ENDS</u>
4"	1.5 SQ FT	1.0 SQ FT	1.0 SQ FT*
6"	3.5 SQ FT	2.5SQ FT	2.5SQ FT*
8"	6.3 SQ FT	4.5 SQ FT	4.5 SQ FT*

\* OR AS DESIGNED BY THE ENGINEER.

**NOT TO SCALE**

APPROVED BY	DATE		IRRIGATION SYSTEM THRUST BLOCKING	STD. PLAN NO. <b>IR-02</b>
	JUNE 2016			
CITY ENGINEER				







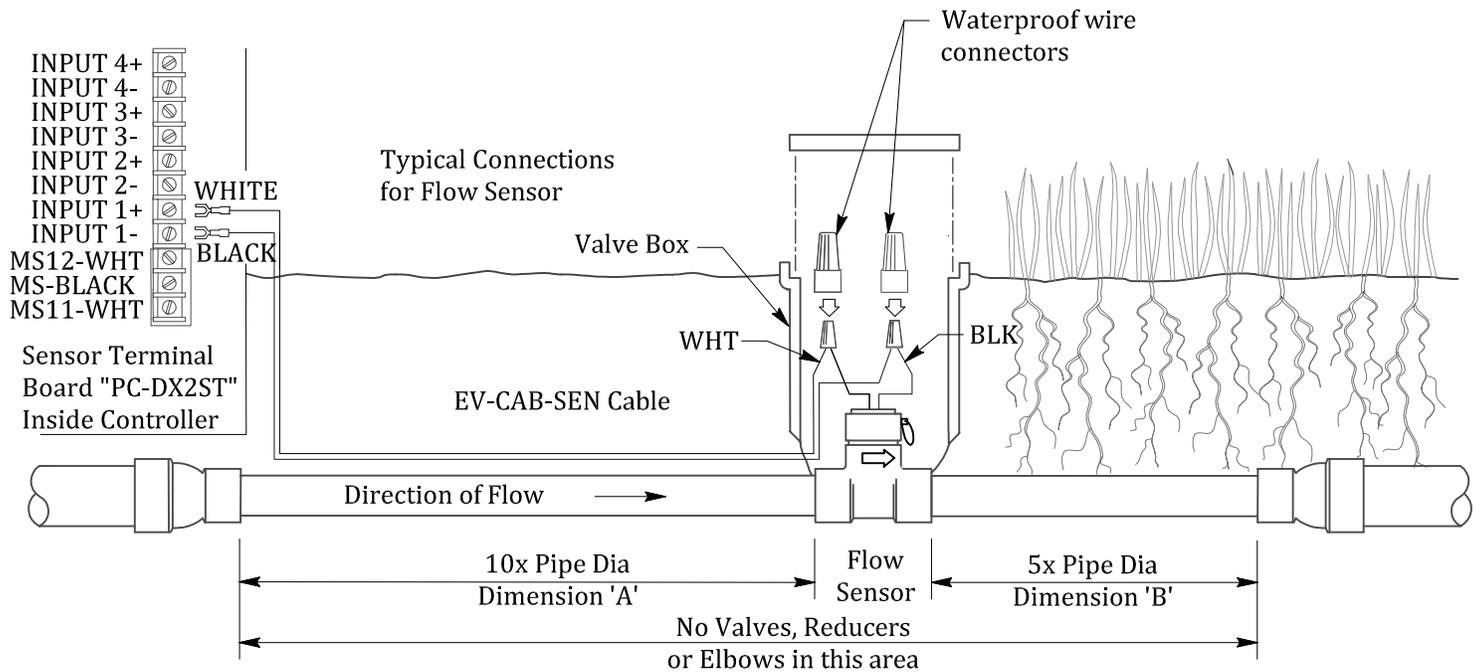

Example: For 3" Flow Sensor, Dimension "A" Minimum 30"  
Dimension "B" Minimum 15"

**NOTES:**

Upon completion of the physical installation of the flow sensor, complete the wiring connection from the flow sensor to the DX2 Controller by following the procedure below.

1. TURN THE POWER OFF AT THE CONTROLLER.
2. At the Flow Sensor:  
Connect the BLACK wire of the Flow Sensor to the BLACK wire of the "EV-CAB-SEN" sensor cable.  
Connect the WHITE wire of the Flow Sensor to the WHITE wire of the "EV-CAP-SEN" sensor cable.  
\*Use the weatherproof connectors provided with the Flow Sensor to make the connection.
3. At the controller:  
Connect the BLACK wire of "EV-CAB-SEN" to "INPUT 1-" of the SENSOR TERMINAL BOARD (PC-DX2ST).  
Connect the WHITE wire of "EV-CAB-SEN" to "INPUT 1-" of the SENSOR TERMINAL BOARD (PC-DX2ST).
4. Turn POWER ON at the Controller.
5. Set the Rain Master "K" and "OFFSET" values for the Flow Sensor at the controller based on the type and size of the Flow Sensor installed.
6. See Standard Plan IR-08 for Irrigation Valve Box Installation

REFER TO THE TABLE PROVIDED WITH THE FLOW SENSOR FOR CORRECT "K" AND "OFFSET" FOR YOUR APPLICATION

**NOT TO SCALE**

APPROVED BY	DATE		<b>FLOW SENSOR DETAIL</b>	STD. PLAN NO.
	JUNE 2016			IR-06
CITY ENGINEER				



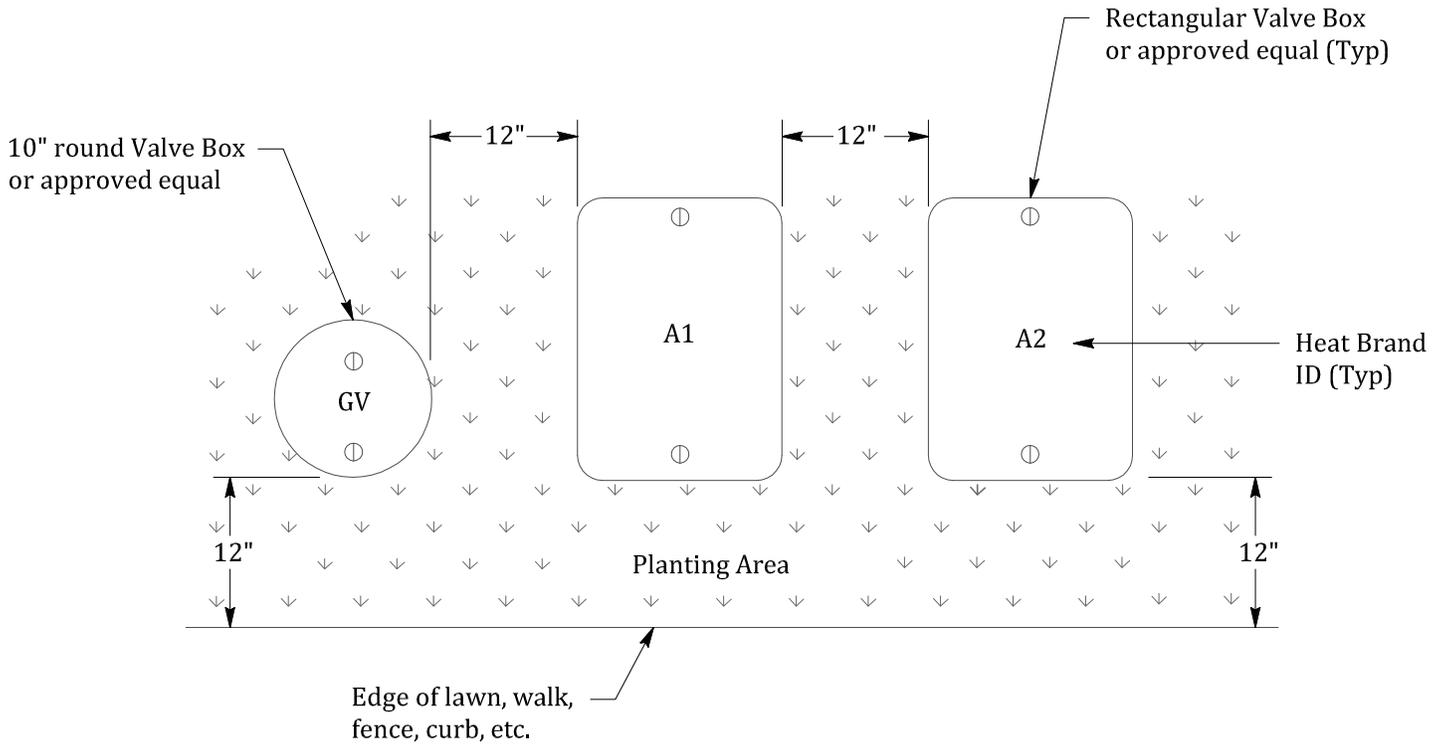

**NOTES:**

1. Center boxes over valves to permit service of valves and unions
2. Set boxes in ground cover/shrub area where possible
3. Set boxes parallel to each other and perpendicular to edge
4. Set boxes 1" above grade in turf areas and 3" above grade in shrub areas
5. Avoid heavily compacting soil around boxes to prevent damaging valve boxes
6. Heat Brand ID on valve box lid with 2" height letters:  
 'X1' for Remote Control Valves ('X' = Controller '1' = station number)  
 'FM' for Flow Meter  
 'MV' for Master Control Valve  
 'GV' for Gate Valve  
 'QC' for Quick Coupling Valve  
 'SP' for Splice Box or Pull Box
7. Install Stainless Steel bolts in locking cover.
8. When non-potable water is used, boxes and lids shall be color-coded purple
9. For all valves 1 ½" and larger, jumbo box shall be used
10. Install valve box extensions as required to completely enclose valve assemblies
11. Cover box cut-outs to prevent soil in box

**NOT TO SCALE**

APPROVED BY		DATE		<b>IRRIGATION VALVE BOX INSTALLATION</b>	STD. PLAN NO.
		JUNE 2016			IR-08
CITY ENGINEER					



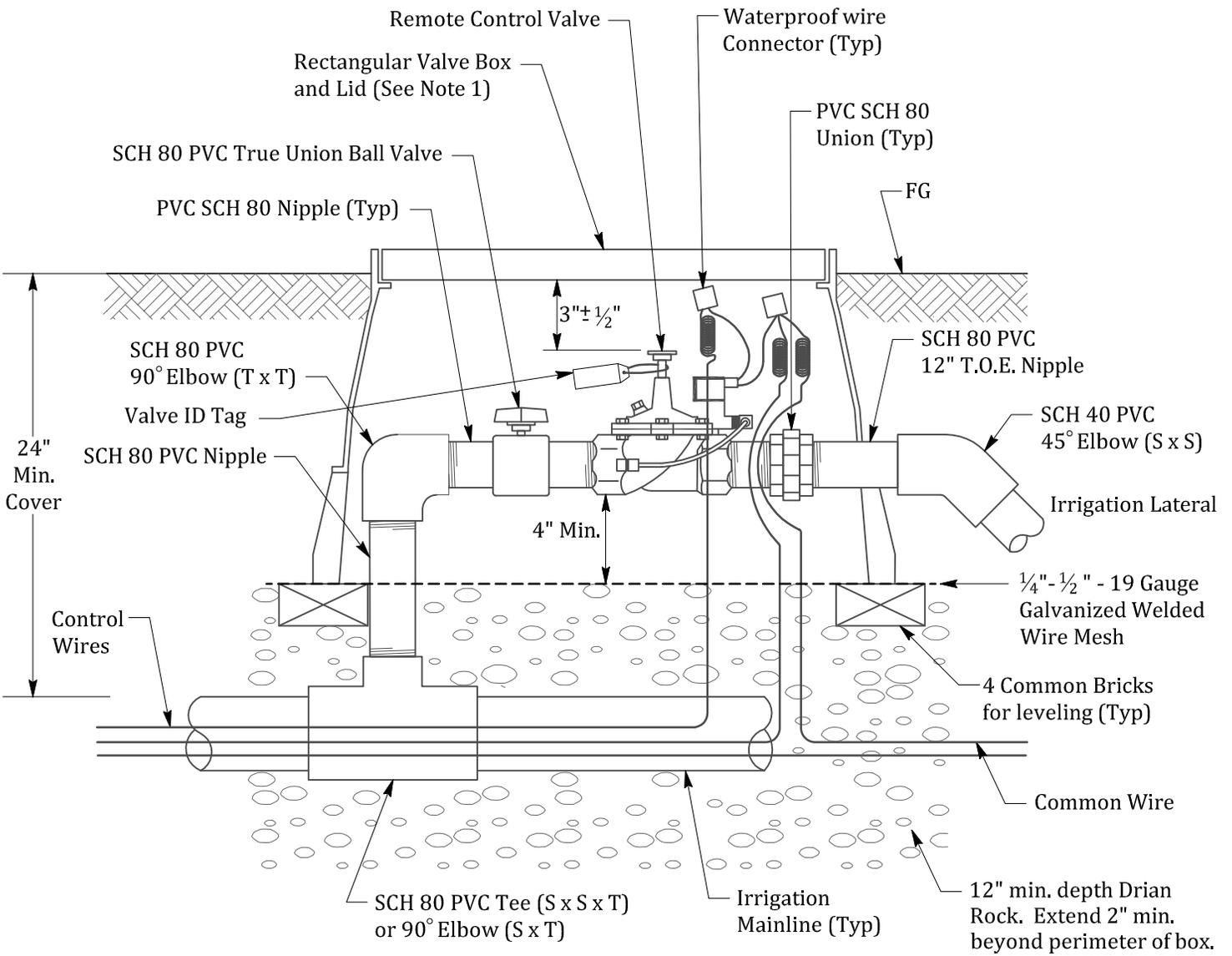

**PLAN**

**NOTES:**

- 1. See Standard Plan IR-08 for Irrigation Valve Box Installation
- 2. Valve ID Tags shall be attached to the remote control valve with the controller and station number
- 3. When used with non-potable water, designate purple color-coding on appropriate appurtenance.
- 4. All low voltage wires shall be 14 gauge for control and 12 gauge for common. Common wires shall be white with a colored strip. Stripe color shall be different for each controller installed. Control wires shall be of one color other than white or green. A different color control wire shall be used for each controller installed.

NOT TO SCALE

APPROVED BY	DATE		<b>REMOTE CONTROL VALVE</b>	STD. PLAN NO.
	JUNE 2016			IR-10
CITY ENGINEER				







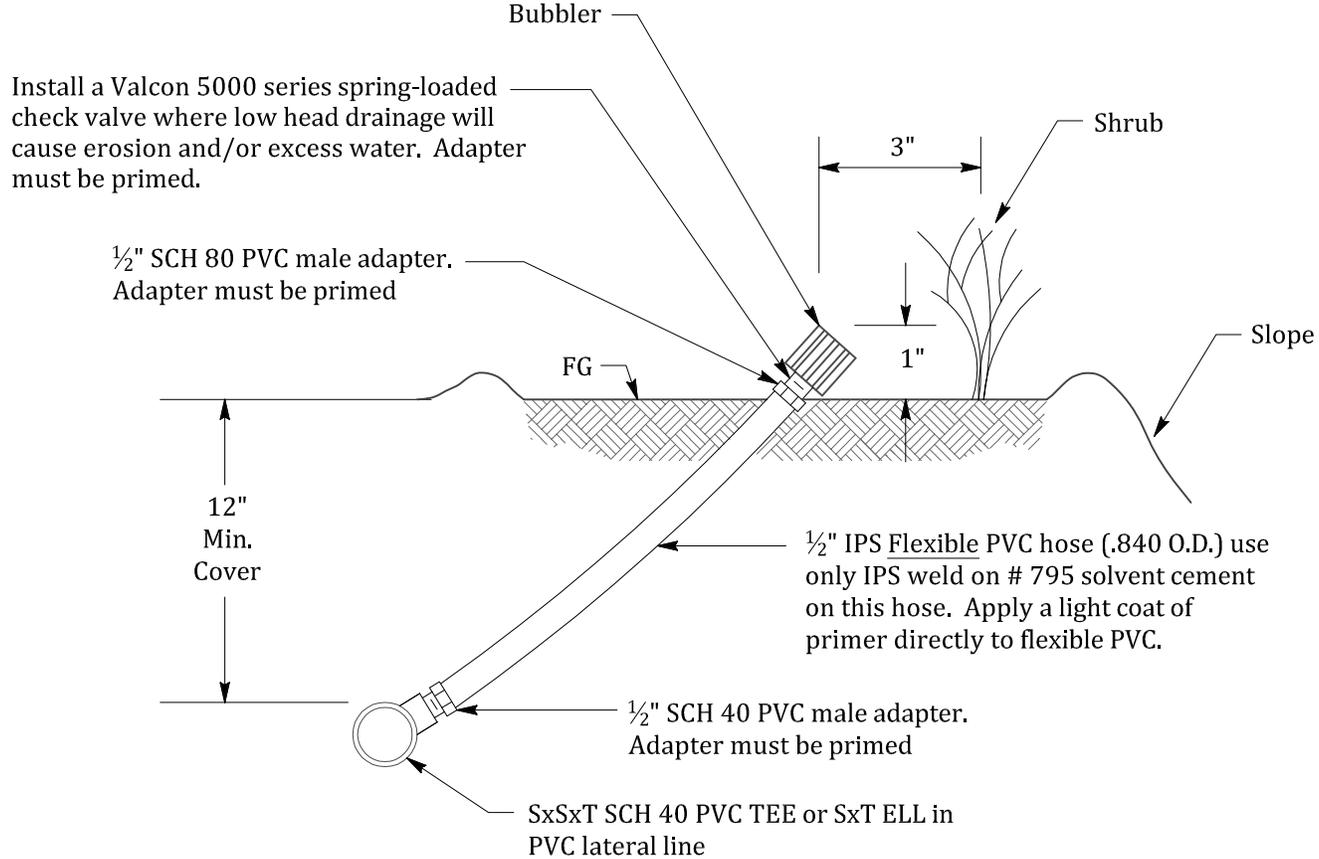

PLAN

NOT TO SCALE

APPROVED BY	DATE		<b>SHRUB BUBBLER AND FLEXIBLE RISER</b>	STD. PLAN NO.
	JUNE 2016			IR-14
CITY ENGINEER				



## PARK FURNISHINGS

ITEM	MANUFACTURER/MODEL OR APPROVED EQUAL	NOTES
PARK BENCH	DUMOR, Inc. MODEL: 119-60 (6' and 8')	Vertical Slat w/back, Non-skateboard, Black, Middle arm rest
PICNIC TABLE	OUTDOOR CREATIONS Inc. SIDE ENTRANCE TABLE, MODEL:100S and 100SLE or 100SRE	Table color: Davis Sequoia Sand 11" x 5.2" New City of Oakley Logo in full relief on legs of table (2), no color
INDIVIDUAL BARBEQUE - METAL	PILOT ROCK, MODEL: B24/8 B2	
FAMILY BARBEQUE - CONCRETE	OUTDOOR CREATIONS, Inc. CONCRETE FAMILY BARBEQUE MODEL: 300A	Barbeque color: Davis Sequoia Sand 11" x 5.2" New City of Oakley logo in full relief on opposing sides (2) of receptacle, no color
DRINKING FOUNTAIN	HAWS BARRIER FREE STAINLESS STEEL PEDESTAL FOUNTAIN MODEL: 3500D-FR	Vandal resistant, green powder coated finish with pet fountain, use Freeze Resistant Bury Valve as specified by the City of Oakley
TRASH RECEPTACLE	OUTDOOR CREATIONS Inc. CONCRETE TRASH RECEPTACLE - ROUND MODEL: 500	Trash Receptacle color: Davis Sequoia Sand 16" x 6" New City of Oakley Logo engraved and painted as specified on 1 side of trash can
RECYCLE RECEPTACLE	DUMOR, Inc. RECEPTACLE DWG NO. 360-0127-32-RC0075 SH1	Receptacle color: Blue
DOG WASTE DISPENSER	ZERO WASTE, MODEL JJ13008	
BLEACHERS	MIRACLE RECREATION EQUIPMENT GALANIZED STEEL MODEL: 98936 ALUMINUM MODEL: 98931	3 Rows x 15'

APPROVED BY	DATE		<b>PARK FURNISHINGS</b>	STD. PLAN NO.
 CITY ENGINEER	JUNE 2016			<b>M-01</b>

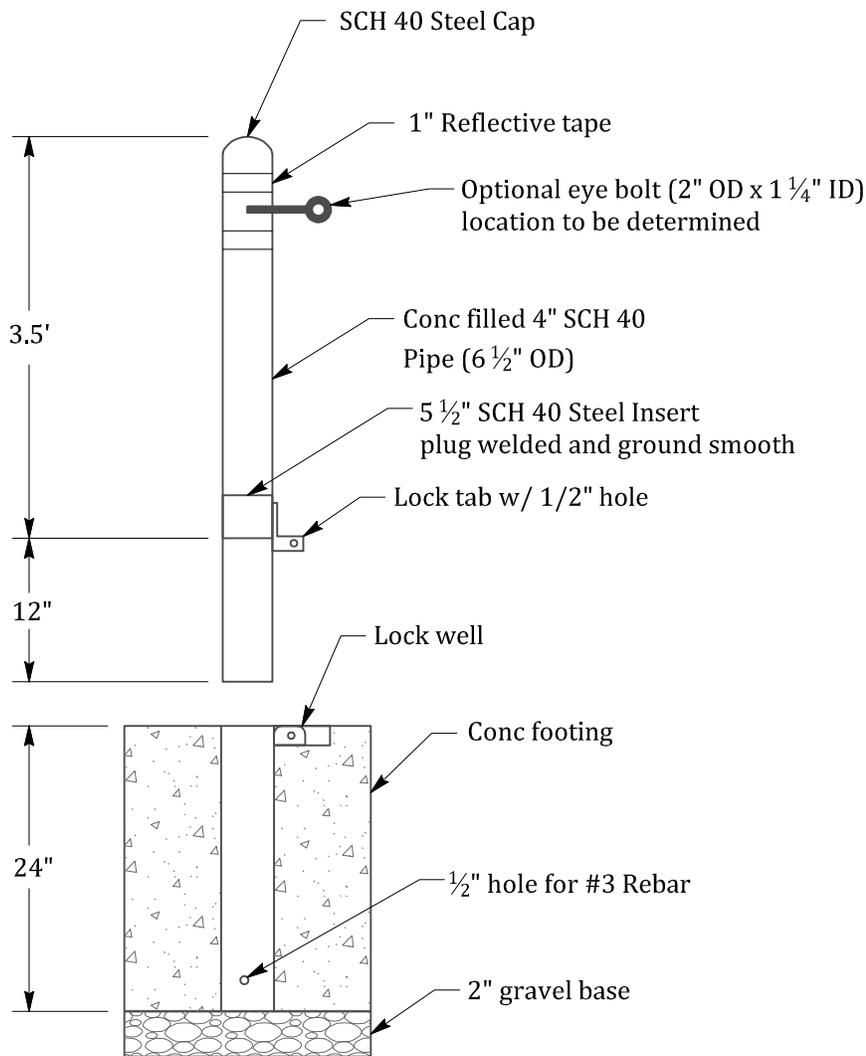

**NOTES:**

- 1. Add reflective tape , two 1" bands at top
- 2. Use manufactured product such as Patterson-Williams (i.e. Model 1100-04-LK removable metal bollard)

NOT TO SCALE

APPROVED BY	DATE		REMOVABLE BOLLARD PARK OR TRAIL	STD. PLAN NO.
	JUNE 2016			M-02
CITY ENGINEER				

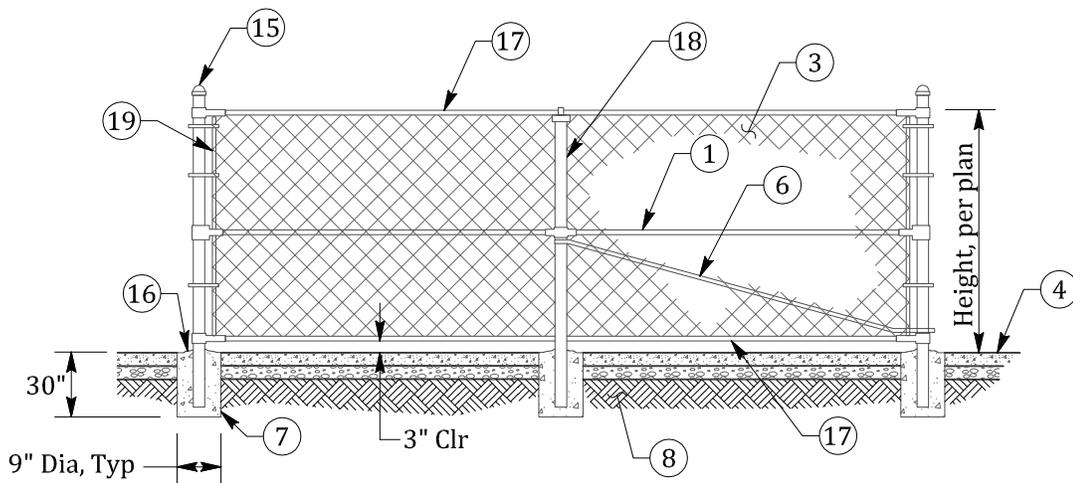

**CHAIN LINK FENCE**

**NOTES:**

- A. Concrete for footings shall be Class "B" (2500 PSI) for more information, see Specifications.
- B. Provide Submittal for all materials.
- C. 36" depth for 4' high fence, 48" depth for 6' high fence and above.
- D. 12" diameter for 4' high fence, 18" diameter for 6' high fence and above.

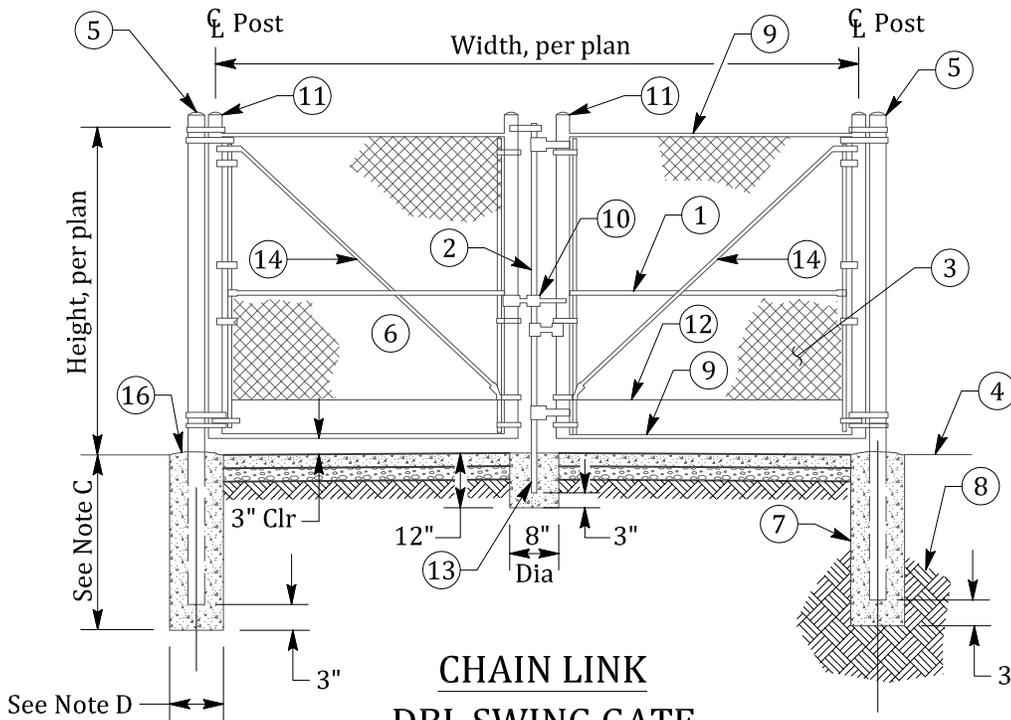

**CHAIN LINK  
DBL SWING GATE**

**LEGEND:**

- ① Midrail 1 5/8" diameter for Gates 6' high minimum
- ② Locking Mechanism
- ③ Chain Link wire Mesh and Posts, Galv. & Powder Coated: Black
- ④ Finish Grade, or Finish Surface
- ⑤ Terminal or Corner Post at Gate, 3" diameter
- ⑥ Truss Rod, at corners and ends
- ⑦ Post Concrete Footing, typical
- ⑧ Compacted subgrade to 95% Relative Compaction.
- ⑨ Gate Rail, 1 7/8" outside diameter
- ⑩ Gate Lock, NIC to be determined by owner.
- ⑪ Gate Frame vertical, 2 1/2" O.D. for 4' high fence, 3" O.D. for greater than 4' high fence.
- ⑫ Gate Bottom, per specifications.
- ⑬ Concrete footing w/sleeve to accept locking mechanism in closed position, typical of 2 (other location to be where gate is open, VIF)
- ⑭ Tension or Tensil, not compression.
- ⑮ Corner Post, 2 1/2" diameter, for corner post see 5 .
- ⑯ Slope away from post.
- ⑰ Top & Bottom Rail, 1 5/8" diameter pipe.
- ⑱ Line Post, 2 1/4" diameter pipe.
- ⑲ Stretcher Bar, typical

**NOT TO SCALE**

APPROVED BY	DATE		FENCE CHAIN LINK	STD. PLAN NO.
	JUNE 2016			M-03
CITY ENGINEER				

