

City of Oakley
ADDENDUM NO. 1 to contract documents for
OAKLEY RECREATION CENTER PROJECT
CIP # 194

BID OPENING DATE: March 8, 2018 at 2:00pm

Notice is hereby given that the following clarifications and revisions are made to the above referenced contract documents:

Updates to the Plans and Specifications pages:

Part III:

Section	Title	Changes
07 41 13.16	STANDING-SEAM METAL ROOF PANELS	Revise section 1.1-A-B-2 as follows (changes in bold): <p style="text-align: center;">Section 07 54 19 “Polyvinyl-Chloride (PVC) Roofing”.</p> Revise section 2.4-A as follows: General: Preformed roof insulation boards manufactured by PVC roof membrane manufacturer.
07 21 00	THERMAL INSULATION	Revise section 1.1-A-B-4 as follows (changes in bold): <p style="text-align: center;">Section 07 54 19 “Polyvinyl-Chloride (PVC) Roofing”.</p>
07 54 23	THERMOPLASTIC-POLYOLEFIN (TPO) ROOFING	Delete section 07 54 23 for THERMOPLASTIC-POLYOLEFIN (TPO) ROOFING and see replacement product in section 07 54 19 - POLYVINYL-CHLORIDE (PVC) ROOFING.
07 54 19	POLYVINYL-CHLORIDE (PVC) ROOFING	Revised roofing product. See attached full specification section.

08 71 00	DOOR HARDWARE	Revise Group 14 as follows (changes in bold):
----------	---------------	---

8	EA	HW HINGE	5BB1HW 4.5 X 4.5	652	IVE
1	EA	PANIC HARDWARE	5547- WDC -DT-LBR	626	VON
1	EA	PANIC HARDWARE	5547- WDC -NL-LBR	626	VON
1	EA	MORTISE CYLINDER	26-091	626	SCH
2	EA	OH STOP & HOLDER	90H	630	GLY
2	EA	CONCEALED CLOSER	2030 SERIES ST-2211	689	LCN
1	EA	SEAL	188S-BK	S-BK	ZER
2	EA	MEETING STILE	328AA	AA	ZER
2	EA	DOOR BOTTOM	360AA	A	ZER
1	EA	THRESHOLD	PER DETAIL		

31 10 00	SITE PREPARATION	Additional language about imported fill material and stockpile backfill material is added under section 3.1E. See attached full specification section.
33 40 00	STORM DRAINAGE UTILITES	<ul style="list-style-type: none"> • Sub-Section 1.2B Geotechnical Report is Referenced. • Sub-Section 2.5 Bedding Material For Storm Drain Piping is added. • Sub-Section 2.6 Subsequent Backfill Material for Storm Drain Piping is added. • Sub-Section 3.1A Referencing the specific city standard trenching plans. See attached full specification section.

Drawing Set:

Civil:

- C5.0 1. The elevations at the stairs leading to the existing building were adjusted to match the latest site plan. See attached full sheet C5.0.

Architecture:

- A2.3 1. Revise roofing note to indicate PVC roofing per attached ASK-02a.
- A8.3 1. Revise roofing note on detail 3/A8.3 to indicate PVC roofing per attached ASK-02b.
2. Revise roofing note on detail 8/A8.3 to indicate PVC roofing per attached ASK-02b.
- A9.7 1. Detail 2 revised to indicate drop in lavatory. See ASK-01.

Plumbing:

- P0.1 1. Revise Lavatory L-1 type as indicated. See attached full sheet P0.1.

Electrical:

- E0.3 1. Revise fixture LR1 as indicated. See attached full sheet E0.3.
- E2.1 1. Revise size of fixture LR1 as indicated. See attached full sheet E2.1.
- E3.3 1. A/V system clarification to note which devices are by others and which devices are by the Contractor. See attached full sheet E3.3.
- E6.1 1. Panel schedule revisions based on lighting revisions. See attached full sheet E6.1.

All bidders shall acknowledge receipt and acceptance of Addendum No. 1 by signing in the space provided at the end of this Addendum and submitting the signed addendum with their proposal.



Jason Kabalin
Associate Engineer
February 22, 2018

Contractor Signature

Date

Company Name

SECTION 07 54 19 - POLYVINYL-CHLORIDE (PVC) ROOFING

PART 1 - GENERAL

1.1 SUMMARY

A. Section Includes:

1. Mechanically fastened, polyvinyl chloride (PVC) roofing system.
2. Vapor retarder.
3. Roof insulation.
4. Cover board.
5. Walkways.

B. Related Requirements:

1. Section 06 16 00 "Sheathing" for wood-based, structural-use roof deck panels.
2. Section 07 62 00 "Sheet Metal Flashing and Trim" for metal roof flashings and counterflashings.
3. Section 07 92 00 "Joint Sealants" for joint sealants, joint fillers, and joint preparation.

1.2 DEFINITIONS

- A. Roofing Terminology: Definitions in ASTM D 1079 and glossary in NRCA's "The NRCA Roofing Manual: Membrane Roof Systems" apply to work of this Section.

1.3 PREINSTALLATION MEETINGS

A. Preinstallation Roofing Conference: Conduct conference at Project site.

1. Meet with Owner, Architect, Owner's insurer if applicable, testing and inspecting agency representative, roofing Installer, roofing system manufacturer's representative, deck Installer, air barrier Installer, and installers whose work interfaces with or affects roofing, including installers of roof accessories and roof-mounted equipment.
2. Review methods and procedures related to roofing installation, including manufacturer's written instructions.
3. Review and finalize construction schedule, and verify availability of materials, Installer's personnel, equipment, and facilities needed to make progress and avoid delays.
4. Examine deck substrate conditions and finishes for compliance with requirements, including flatness and fastening.
5. Review structural loading limitations of roof deck during and after roofing.
6. Review base flashings, special roofing details, roof drainage, roof penetrations, equipment curbs, and condition of other construction that affects roofing system.
7. Review governing regulations and requirements for insurance and certificates if applicable.
8. Review temporary protection requirements for roofing system during and after installation.
9. Review roof observation and repair procedures after roofing installation.

1.4 ACTION SUBMITTALS

A. Product Data: For each type of product.

1. For insulation and roof system component fasteners, include copy of FM Approvals' RoofNav listing.

- B. Sustainable Design Submittals: Provide documentation of compliance with applicable requirements set forth in Section 01 81 13.33 "Sustainable Design Requirements - CALGreen."

1. Product Test Reports: For roof materials, documentation indicating that roof materials comply with Solar Reflectance Index requirements.
2. Product Data: For adhesives and sealants, indicating VOC content.
- C. Shop Drawings: Include roof plans, sections, details, and attachments to other work, including the following:
 1. Layout and thickness of insulation.
 2. Base flashings and membrane terminations.
 3. Flashing details at penetrations.
 4. Tapered insulation thickness and slopes.
 5. Roof plan showing orientation of steel roof deck and orientation of roof membrane, fastening spacings, and patterns for mechanically fastened roofing system.
 6. Insulation fastening patterns for corner, perimeter, and field-of-roof locations.
 7. Tie-in with air barrier.
- D. Samples for Verification: For the following products:
 1. Roof membrane and flashing, of color required.
 2. Walkway pads or rolls, of color required.
- E. Wind Uplift Resistance Submittal: For roofing system, indicating compliance with wind uplift performance requirements.

1.5 INFORMATIONAL SUBMITTALS

- A. Qualification Data: For Installer and manufacturer.
- B. Product Test Reports: For roof membrane and insulation, tests performed by independent qualified testing agency indicating compliance with specified requirements.
- C. Evaluation Reports: For components of roofing system, from ICC-ES.
- D. Field Test Reports:
 1. Fastener-pullout test results and manufacturer's revised requirements for fastener patterns.
- E. Sample Warranties: For manufacturer's special warranties.

1.6 CLOSEOUT SUBMITTALS

- A. Maintenance Data: For roofing system to include in maintenance manuals.

1.7 QUALITY ASSURANCE

- A. Installer Qualifications: A qualified firm that is approved, authorized, or licensed by roofing system manufacturer to install manufacturer's product and that is eligible to receive manufacturer's special warranty.

1.8 DELIVERY, STORAGE, AND HANDLING

- A. Deliver roofing materials to Project site in original containers with seals unbroken and labeled with manufacturer's name, product brand name and type, date of manufacture, approval or listing agency markings, and directions for storing and mixing with other components.
- B. Store liquid materials in their original undamaged containers in a clean, dry, protected location and within the temperature range required by roofing system manufacturer. Protect stored liquid material from direct sunlight.

1. Discard and legally dispose of liquid material that cannot be applied within its stated shelf life.
- C. Protect roof insulation materials from physical damage and from deterioration by sunlight, moisture, soiling, and other sources. Store in a dry location. Comply with insulation manufacturer's written instructions for handling, storing, and protecting during installation.
- D. Handle and store roofing materials, and place equipment in a manner to avoid permanent deflection of deck.

1.9 FIELD CONDITIONS

- A. Weather Limitations: Proceed with installation only when existing and forecasted weather conditions permit roofing system to be installed according to manufacturer's written instructions and warranty requirements.

1.10 WARRANTY

- A. Special Warranty: Manufacturer agrees to repair or replace components of roofing system that fail in materials or workmanship within specified warranty period.
 1. Special warranty includes roof membrane, base flashings, roof insulation, fasteners, cover boards, vapor barriers, walkway products, and other components of roofing system.
 2. Warranty Period: 20 years from date of Substantial Completion.
- B. Special Project Warranty: Submit roofing Installer's warranty, on warranty form at end of this Section, signed by Installer, covering the Work of this Section, including all components of roofing system such as roof membrane, base flashing, roof insulation, fasteners, cover boards, vapor retarders, and walkway products, for the following warranty period:
 1. Warranty Period: Three years from date of Substantial Completion.

PART 2 - PRODUCTS

2.1 PERFORMANCE REQUIREMENTS

- A. General Performance: Installed roofing and base flashings shall withstand specified uplift pressures, thermally induced movement, and exposure to weather without failure due to defective manufacture, fabrication, installation, or other defects in construction. Roof system and flashings shall remain watertight.
 1. Accelerated Weathering: Roof membrane shall withstand 2000 hours of exposure when tested according to ASTM G 152, ASTM G 154, or ASTM G 155.
 2. Impact Resistance: Roof membrane shall resist impact damage when tested according to ASTM D 3746, ASTM D 4272/D 4272M, or the "Resistance to Foot Traffic Test" in FM Approvals 4470.
- B. Material Compatibility: Roofing materials shall be compatible with one another and adjacent materials under conditions of service and application required, as demonstrated by roof membrane manufacturer based on testing and field experience.
- C. Wind Uplift Resistance: Design roofing system to resist wind uplift pressures indicated in Drawings when tested according to FM Approvals 4474, UL 580, or UL 1897.
- D. Solar Reflectance Index (SRI): Not less than 78 when calculated according to ASTM E 1980, based on testing identical products by a qualified testing agency.

- E. Energy Performance: Roofing system shall have an initial solar reflectance of not less than 0.70 and an emissivity of not less than 0.75 when tested according to CRRC-1.
- F. Exterior Fire-Test Exposure: ASTM E 108 or UL 790, Class A; for application and roof slopes indicated; testing by a qualified testing agency. Identify products with appropriate markings of applicable testing agency.

2.2 POLYVINYL CHLORIDE (PVC) ROOFING

- A. PVC Sheet: ASTM D 4434/D 4434M, Type III, fabric reinforced.
 - 1. Manufacturers: Subject to compliance with requirements, provide products by the following, from the following product lines:
 - a. Duro-Last Roofing, Inc; Duro-Tuff Series.
 - b. Sika Sarnafil; Sarnaplan Series.
 - 2. Thickness: 50 mils (1.27 mm).
 - 3. Exposed Face Color: White.
- B. Source Limitations: Obtain components for roofing system from roof membrane manufacturer or manufacturers approved by roof membrane manufacturer.

2.3 AUXILIARY ROOFING MATERIALS

- A. General: Auxiliary materials recommended by roofing system manufacturer for intended use and compatible with other roofing components.
 - 1. Adhesives and Sealants: Comply with requirements set forth in Section 01 81 13.33 "Sustainable Design Requirements - CALGreen."
- B. Sheet Flashing: Manufacturer's standard sheet flashing of same material, type, reinforcement, thickness, and color as PVC sheet.
- C. Prefabricated Pipe Flashings: As recommended by roof membrane manufacturer.
- D. Bonding Adhesive: Manufacturer's standard, water based.
- E. Metal Termination Bars: Manufacturer's standard, predrilled stainless steel or aluminum bars, approximately 1 by 1/8 inch (25 by 3 mm) thick; with anchors.
- F. Fasteners: Factory-coated steel fasteners and metal or plastic plates complying with corrosion-resistance provisions in FM Approvals 4470, designed for fastening roofing components to substrate, and acceptable to roofing system manufacturer.
- G. Miscellaneous Accessories: Provide pourable sealers, preformed cone and vent sheet flashings, preformed inside and outside corner sheet flashings, T-joint covers, lap sealants, termination reglets, and other accessories.

2.4 VAPOR RETARDER

- A. Self-Adhering-Sheet Vapor Retarder: Polyethylene film laminated to layer of butyl rubber adhesive, minimum 30-mil- (0.76-mm-) total thickness; maximum permeance rating of 0.1 perm (6 ng/Pa x s x sq. m); cold applied, with slip-resisting surface and release paper backing. Provide primer when recommended by vapor retarder manufacturer.

2.5 ROOF INSULATION

- A. General: Preformed roof insulation boards manufactured or approved by PVC roof membrane manufacturer.
- B. Polyisocyanurate Board Insulation: ASTM C 1289, Type II, Class 1, Grade 2, felt or glass-fiber mat facer on both major surfaces.
 - 1. Thickness: As indicated in Drawings, except not less than 2 inches.
- C. Tapered Insulation: Provide factory-tapered insulation boards.
 - 1. Material: Match roof insulation.
 - 2. Minimum Thickness: 1/4 inch (6.35 mm).
 - 3. Slope:
 - a. Saddles and Crickets: 1/2 inch per foot (1:24) unless otherwise indicated on Drawings.

2.6 INSULATION ACCESSORIES

- A. General: Roof insulation accessories recommended by insulation manufacturer for intended use and compatibility with other roofing system components.
- B. Fasteners: Factory-coated steel fasteners and metal or plastic plates complying with corrosion-resistance provisions in FM Approvals 4470, designed for fastening roof insulation and cover boards to substrate, and acceptable to roofing system manufacturer.
- C. Cover Board: ASTM C 1177/C 1177M, glass-mat, water-resistant gypsum board.
 - 1. Products: Subject to compliance with requirements, provide one of the following:
 - a. Georgia-Pacific Building Products; Dens Deck Prime.
 - 2. Thickness: 1/4 inch (6 mm).
 - 3. Surface Finish: Factory primed.

2.7 WALKWAYS

- A. Flexible Walkways: Factory-formed, nonporous, heavy-duty, slip-resisting, surface-textured walkway pads or rolls, approximately 3/16 inch (5 mm) thick and acceptable to roofing system manufacturer.
 - 1. Size: Approximately 36 by 60 inches (914 by 1524 mm).
 - 2. Color: Contrasting with roof membrane.

PART 3 - EXECUTION

3.1 EXAMINATION

- A. Examine substrates, areas, and conditions, with Installer present, for compliance with requirements and other conditions affecting performance of the Work.
 - 1. Verify that roof openings and penetrations are in place, curbs are set and braced, and roof-drain bodies are securely clamped in place.
 - 2. Verify that wood blocking, curbs, and nailers are securely anchored to roof deck at penetrations and terminations and that nailers match thicknesses of insulation.
- B. Proceed with installation only after unsatisfactory conditions have been corrected.

3.2 PREPARATION

- A. Clean substrate of dust, debris, moisture, and other substances detrimental to roofing system installation according to roofing system manufacturer's written instructions. Remove sharp projections.
- B. Prevent materials from entering and clogging roof drains and conductors and from spilling or migrating onto surfaces of other construction. Remove roof-drain plugs when no work is taking place or when rain is forecast.
- C. Perform fastener-pullout tests according to roof system manufacturer's written instructions.
 - 1. Submit test result within 24 hours of performing tests.
 - a. Include manufacturer's requirements for any revision to previously submitted fastener patterns required to achieve specified wind uplift requirements.

3.3 ROOFING INSTALLATION, GENERAL

- A. Install roofing system according to roofing system manufacturer's written instructions.
- B. Complete terminations and base flashings and provide temporary seals to prevent water from entering completed sections of roofing system at end of workday or when rain is forecast. Remove and discard temporary seals before beginning work on adjoining roofing.
- C. Install roof membrane and auxiliary materials to tie in to existing roofing to maintain weathertightness of transition.
- D. Coordinate installation and transition of roofing system component serving as an air barrier with air barrier specified under Section 07 25 00 "Weather Barriers."

3.4 VAPOR RETARDER INSTALLATION

- A. Self-Adhering-Sheet Vapor Retarder: Prime substrate if required by manufacturer. Install self-adhering-sheet vapor retarder over area to receive vapor retarder, side and end lapping each sheet a minimum of 3-1/2 and 6 inches (90 and 150 mm), respectively.
 - 1. Extend vertically up parapet walls and projections to a minimum height equal to height of insulation and cover board.
 - 2. Seal laps by rolling.
- B. Completely seal vapor retarder at terminations, obstructions, and penetrations to prevent air movement into roofing system.

3.5 INSULATION INSTALLATION

- A. Coordinate installing roofing system components so insulation is not exposed to precipitation or left exposed at end of workday.
- B. Comply with roofing system and insulation manufacturer's written instructions for installing roof insulation.
- C. Installation Over Wood Panel Decking:
 - 1. Install base layer of insulation with joints staggered not less than 24 inches (610 mm) in adjacent rows.

- a. Trim insulation neatly to fit around penetrations and projections, and to fit tight to intersecting sloping roof decks.
 - b. Make joints between adjacent insulation boards not more than 1/4 inch (6 mm) in width.
 - c. At internal roof drains, slope insulation to create a square drain sump with each side equal to the diameter of the drain bowl plus 24 inches (610 mm).
 - 1) Trim insulation so that water flow is unrestricted.
 - d. Fill gaps exceeding 1/4 inch (6 mm) with insulation.
 - e. Cut and fit insulation within 1/4 inch (6 mm) of nailers, projections, and penetrations.
 - f. Mechanically attach base layer of insulation using mechanical fasteners specifically designed and sized for fastening specified board-type roof insulation to wood panel decks.
 - 1) Fasten insulation to resist specified uplift pressure at corners, perimeter, and field of roof.
2. Install upper layers of insulation and tapered insulation with joints of each layer offset not less than 12 inches (305 mm) from previous layer of insulation.
- a. Staggered end joints within each layer not less than 24 inches (610 mm) in adjacent rows.
 - b. Trim insulation neatly to fit around penetrations and projections, and to fit tight to intersecting sloping roof decks.
 - c. Make joints between adjacent insulation boards not more than 1/4 inch (6 mm) in width.
 - d. At internal roof drains, slope insulation to create a square drain sump with each side equal to the diameter of the drain bowl plus 24 inches (610 mm).
 - 1) Trim insulation so that water flow is unrestricted.
 - e. Fill gaps exceeding 1/4 inch (6 mm) with insulation.
 - f. Cut and fit insulation within 1/4 inch (6 mm) of nailers, projections, and penetrations.
 - g. Adhere each layer of insulation to substrate using adhesive, with one of the following methods:
 - 1) Set each layer of insulation in ribbons of bead-applied insulation adhesive, firmly pressing and maintaining insulation in place.
 - 2) Set each layer of insulation in a uniform coverage of full-spread insulation adhesive, firmly pressing and maintaining insulation in place.

3.6 INSTALLATION OF COVER BOARDS

- A. Install cover boards over insulation with long joints in continuous straight lines with end joints staggered between rows. Offset joints of insulation below a minimum of 6 inches (150 mm) in each direction.
 1. Trim cover board neatly to fit around penetrations and projections, and to fit tight to intersecting sloping roof decks.
 2. At internal roof drains, conform to slope of drain sump.
 - a. Trim cover board so that water flow is unrestricted.
 3. Cut and fit cover board tight to nailers, projections, and penetrations.

3.7 MECHANICALLY FASTENED ROOFING INSTALLATION

- A. Mechanically fasten roof membrane over area to receive roofing according to roofing system manufacturer's written instructions.
- B. Unroll roof membrane and allow to relax before installing.
- C. Start installation of roofing in presence of roofing system manufacturer's technical personnel.
- D. Accurately align roof membrane, and maintain uniform side and end laps of minimum dimensions required by manufacturer. Stagger end laps.
- E. Mechanically fasten or adhere roof membrane securely at terminations, penetrations, and perimeter of roofing.
- F. Apply roof membrane with side laps shingled with slope of roof deck where possible.
- G. In-Seam Attachment: Secure one edge of PVC sheet using fastening plates or metal battens centered within seam, and mechanically fasten PVC sheet to roof deck.
- H. Seams: Clean seam areas, overlap roof membrane, and hot-air weld side and end laps of roof membrane and sheet flashings to ensure a watertight seam installation.
 - 1. Test lap edges with probe to verify seam weld continuity. Apply lap sealant to seal cut edges of roof membrane and sheet flashings.
 - 2. Verify field strength of seams a minimum of twice daily, and repair seam sample areas.
 - 3. Repair tears, voids, and lapped seams in roof membrane that do not comply with requirements.
- I. Spread sealant bed over deck-drain flange at roof drains, and securely seal roof membrane in place with clamping ring.

3.8 BASE FLASHING INSTALLATION

- A. Install sheet flashings and preformed flashing accessories, and adhere to substrates according to roofing system manufacturer's written instructions.
- B. Apply bonding adhesive to substrate and underside of sheet flashing at required rate, and allow to partially dry. Do not apply to seam area of flashing.
- C. Flash penetrations and field-formed inside and outside corners with cured or uncured sheet flashing.
- D. Clean seam areas, overlap, and firmly roll sheet flashings into the adhesive. Hot-air weld side and end laps to ensure a watertight seam installation.
- E. Terminate and seal top of sheet flashings and mechanically anchor to substrate through termination bars.

3.9 WALKWAY INSTALLATION

- A. Flexible Walkways: Install walkway products according to manufacturer's written instructions.
 - 1. Provide 6-inch (76-mm) clearance between adjoining pads.
 - 2. Heat weld to substrate or adhere walkway products to substrate with compatible adhesive according to roofing system manufacturer's written instructions.

3.10 FIELD QUALITY CONTROL

- A. Testing Agency: Owner will engage a qualified testing agency to inspect substrate conditions, surface preparation, roof membrane application, sheet flashings, protection, and drainage components, and to furnish reports to Architect.
- B. Final Roof Inspection: Arrange for roofing system manufacturer's technical personnel to inspect roofing installation on completion, in presence of Architect, and to prepare inspection report.
- C. Repair or remove and replace components of roofing system where inspections indicate that they do not comply with specified requirements.
- D. Additional testing and inspecting, at Contractor's expense, will be performed to determine if replaced or additional work complies with specified requirements.

3.11 PROTECTING AND CLEANING

- A. Protect roofing system from damage and wear during remainder of construction period. When remaining construction does not affect or endanger roofing, inspect roofing system for deterioration and damage, describing its nature and extent in a written report, with copies to Architect and Owner.
- B. Correct deficiencies in or remove roofing system that does not comply with requirements, repair substrates, and repair or reinstall roofing system to a condition free of damage and deterioration at time of Substantial Completion and according to warranty requirements.
- C. Clean overspray and spillage from adjacent construction using cleaning agents and procedures recommended by manufacturer of affected construction.

END OF SECTION 07 54 19

SECTION 31 10 00

SITE PREPARATION

PART 1 - GENERAL

1.1 RELATED WORK

- A. Section 02 40 00: Selective Demolition
- B. Section 32 12 00: Flexible Paving
- C. Section 32 16 00: Curb, Gutter, Sidewalks, Driveways

1.2 REFERENCES

- A. Current Caltrans Standard Specifications:
 - 1. Section 15 – Existing Highway Facilities
 - 2. Section 17 – Clearing and Grubbing
- B. Geotechnical Investigation Report provided by BSK Associates, dated March 1, 2017

1.3 SUBMITTAL

1.4 SUMMARY

- A. The work consists of removing objectionable material from within the limits of work.

PART 2 - PRODUCTS (NOT USED)

PART 3 - EXECUTION

3.1 DEMOLITION, STRIPPING, GRUBBING AND ROUGH GRADING

- A. Demolition
 - 1. Existing concrete and asphalt concrete paving, concrete curbs, and walks shall be sawcut, broken up and removed where shown on the plans for new construction. In addition, the base rock material underneath paved areas shall be removed where no new concrete or asphalt surfacing is to be placed. In areas to receive new paving, existing aggregate base may remain in place unless otherwise specified.
- B. Stripping
 - 1. Existing topsoil shall be stripped to a depth of 6” (or deeper where directed by the Project Manager) as necessary to remove all vegetation, organic matter, or other objectionable material in those areas to be graded.
 - 2. Topsoil not containing vegetation shall be stockpiled on-site for later use as topsoil backfill to the extent needed for the project.

- C. Grubbing:
1. In unpaved areas, where existing vegetation has been removed as shown on the drawings, neatly cut and remove all roots greater than one inch in diameter, to a depth of one foot.
 2. In areas to be paved, neatly cut and remove all encountered roots to a depth of at least two feet below finished grade.
- D. Excavation Around Trees to Remain:
1. Where trenching for utilities is required within drip lines, tunneling under and around roots shall be by hand digging. Main lateral roots and tap roots shall not be cut.
 2. Where excavation for new construction is required within the drip line of trees, hand excavation shall be employed to minimize damage to root systems. Roots shall be relocated in backfill areas wherever possible. If large main lateral roots are encountered, they shall be exposed beyond excavation limits as required to bend and relocate without breaking.
 3. If encountered immediately adjacent to the location of new construction and relocation is not practical, roots shall be cut approximately 6 inches back from new construction. Project Manager approval is required to cut roots greater than 3/4 inches in diameter.
 4. Exposed roots shall not be allowed to dry out before permanent backfill is placed. Temporary earth cover shall be provided, or roots shall be packed with wet peat moss or 4 layers of wet untreated burlap and temporarily supported and protected from damage until permanently relocated and covered with backfill.
 5. Branching structure shall be thinned in accordance with National Arborists Association "Pruning Standards and Practices" to balance loss to root system caused by damage or cutting of root system. Thinning shall not exceed 30% of existing branching structure.
- E. Rough Grading and Earthwork
1. Existing stockpiled material shall be used on-site as backfill to meet the proposed subgrade elevations.
 2. A BSK representative should be present on-site during grading to visually confirm the suitability of the on-site soil to be used as fill and backfill, especially the existing stockpile material.
 3. Base Bid: Existing stockpiled material shall be used as backfill based on the order of work listed below:
 - a. Building Site (1st Priority)
 - b. Parking lot (2nd Priority)
 - c. Stockpiled in Field (3rd Priority)
 4. Add Alternate #1: Existing stockpiled material shall be used as backfill based on the order of work listed below:
 - a. Building Site (1st Priority)
 - b. Parking Lot (2nd Priority)
 - c. Field (3rd Priority)
 5. Contractor shall refer to the geotechnical investigation report provided by BSK Associates dated March 1, 2017 for subgrade preparation and backfill compaction requirements.
 6. Maximum particle size for fill material should be limited to 3 inches, with at least 90 percent by weight passing 1-inch sieve.

- 7. If there is not enough stockpile material to meet the proposed subgrade elevations at the building and parking lot site contractor shall strip additional material from the field to be used as backfill as necessary. Contractor shall notify the engineer if there is a shortage of engineered fill for the building and parking lot site and shall provide the shortage quantity in cubic yards. Engineer shall provide the location for striping additional backfill material and provide new finish grade elevations in the field.
- 8. Contractor shall notify engineer if there is any remaining engineered fill from the existing stockpile after the completion of backfilling the building, parking lot and field to proposed subgrade elevations.
- 9. If there is a shortage of on-site backfill material, imported fill material shall be granular in nature and conform to the following minimum criteria:

Imported Fill Criteria	
Plasticity Index	15 or Less
Liquid Limit	Less than 30%
Percent Passing #200 Sieve	8% - 40%
R-Value*	50 or Greater

*R-value requirement applies to import fill to be placed within the upper 2 feet below finished pavement subgrade and within 3 feet laterally of the pavement limits.

- 10. Imported fill shall not be more corrosive than the on-site soils and should not be classified as being more corrosive than “moderately corrosive”.
- 11. Open graded materials such as crushed rock and pea gravel are not recommended for use as backfill for excavations.

3.2 TREE TRIMMING

- A. Contractor shall advise Project Manager of all trees (roots or branches) that are in the way of his/her work or operations.

3.3 DISPOSAL

- A. All non-hazardous debris, site strippings, and objectionable material becomes the property of the Contractor and shall be removed and disposed of in a legal manner off the Owner's property.
- B. Contractor shall ensure optimal diversion of construction waste materials generated by the Work from landfill disposal.
- C. Disposal shall be performed within 24 hours after removal of the material and shall not be left until the final clean-up period.

PART 4 - MEASUREMENT AND PAYMENT

4.1 MEASUREMENT

- A. All work involved with the BASE BID ITEMS, including but not limited to TREE REMOVAL will be measured by “each” complete in place, unless otherwise specified in the Contract Documents.

- B. All work involved in both the BASE BID and ADD ALTERNATE #1 including but not limited to CLEARING AND GRUBBING, and ROUGH GRADING AND BACKFILLING will be measured by “each” complete in place, unless otherwise specified in the Contract Documents.

4.2 PAYMENT

- A. CLEARING AND GRUBBING shall be at the cost indicated in the Bid Schedule. The contract price paid per lump sum basis for clearing and grubbing shall include but not limited to full compensation for furnishing all labor, equipment, materials, and incidentals for doing all the work involved for clearing and grubbing including but not limited to the removal of irrigation piping and appurtenances, tree root balls, tree stumps, large cobbles, and other miscellaneous items, as specified on the Plans and in the Standard Specifications, these Technical Specifications and the Special Provisions, and as directed by the Engineer. Additionally, no payment will be made for work, equipment, or materials not covered in these plans and specifications, but necessary to insure a completed project as specified.
- B. ROUGH GRADING AND BACKFILLING shall be at the cost indicated in the Bid Schedule. The contract price paid per lump sum basis for rough grading and backfilling shall include but not limited to full compensation for furnishing all labor, equipment, materials, and incidentals for doing all the work involved in grading and backfilling including the utilization of the existing stockpiled material and stripping additional engineered fill from the field as necessary to meet the proposed subgrade elevations, as specified on the Plans and in the Standard Specifications, these Technical Specifications and the Special Provisions, and as directed by the Engineer. Additionally, no payment will be made for work, equipment, or materials not covered in these plans and specifications, but necessary to insure a completed project as specified.
- C. TREE REMOVAL shall be at the cost indicated in the Bid Schedule. The contract prices paid per lump sum basis for tree removal includes, but not limited to, full compensation for furnishing all labor, material, tools, equipment, and incidentals required to remove and dispose of existing trees as shown on the Plans, as specified in the Standard Specifications, these Technical Specifications and the Special Provisions, and as directed by the Engineer. Additionally, no payment will be made for work, equipment, or materials not covered in these plans and specifications, but necessary to insure a completed project as specified.

END OF SECTION

SECTION 33 40 00

STORM DRAINAGE UTILITIES

PART 1 - GENERAL

1.1 RELATED WORK

- A. City of Oakley Standard Drawings

1.2 REFERENCES

- A. City of Oakley Standard Drawings
 - 1. SD-03 Pipe Trench Detail and SD-04 Pipe Trench Notes
- B. Geotechnical Investigation Report provided by BSK Associates dated March 1, 2017
- C. American Society for Testing and Materials (ASTM):
 - 1. C76 Reinforced Concrete Culvert, Storm Drain, and Sewer Pipe
 - 2. C150 Portland Cement
 - 3. F477 Elastomeric Seals (Gaskets) for Joining Plastic Pipe
 - 4. C478 Precast Reinforced Concrete Manhole Sections
 - 5. D3034 Type PSM Polyvinyl Chloride (PVC) Sewer Pipe and Fittings
 - 6. D2729 Perforated PVC Drain Pipe
- D. California Department of Transportation (Caltrans) Standard Specifications:
 - 1. Section 26 Aggregate Bases
 - 2. Section 51 Concrete Structures
 - 3. Section 52 Reinforcement
 - 4. Section 55 Steel Structures
 - 5. Section 61 Culvert and Drainage Pipe Joints
 - 6. Section 62 Alternative Culvers
 - 7. Section 63 Cast in Place Concrete Pipe
 - 8. Section 64 Plastic Pipe
 - 9. Section 65 Reinforced Concrete Pipe
 - 10. Section 66 Corrugated Metal Pipe
 - 11. Section 68 Subsurface Drains
 - 12. Section 70 Miscellaneous Facilities
 - 13. Section 90 Portland Cement Concrete
- E. California Code of Regulations Title 8, Industrial Relations and CAL/OSHA Construction Safety Orders
- F. Contra Costa County Provision C.3. of the Municipal Regional Stormwater Permit (MRP)
- G. National Pollutant Discharge Elimination System General Permit (NPDES)

1.3 SUMMARY

- A. The work described in this section includes the materials for storm drainage piping, appurtenances and utility structures.

PART 2 - PRODUCTS

2.1 POLYVINYL CHLORIDE (PVC) PIPE

- A. Polyvinyl chloride pipe and fittings shall conform to ASTM D3034, SDR 35 with bell and spigot type rubber-gasketed joints.
- B. Schedule 80 polyvinyl chloride (PVC) pipe in accordance with ASTM D1784, shall be used to connect the perforated under drain pipe to the catch basins within bio-treatment areas.

2.2 PERFORATED UNDERDRAIN

- A. Perforated underdrain shall be polyvinyl Chloride (PVC) pipe up to and including 15 inches in diameter, conforming to ASTM D3034, SDR 35. Perforations shall be 3/8 inch size. Joints shall be a bell and spigot assembly with elastomeric sealing gaskets. Sealing gaskets shall meet the requirements of ASTM F477. Solvent cement joints shall not be allowed. All pipe joints shall be made using manufactured PVC couplings. Band type couplings shall not be allowed.

2.3 CATCH BASIN AND MANHOLES

- A. Precast drainage structures shall conform to Section 70-1.02H and 71-1.03 of the CDT Standard Specifications and ASTM C478 and shall be of the size and shape shown on the drawings. Equivalent poured-in-place structures may be used at Contractor's option.
- B. Grates for catch basins shall have reticuline bars as shown on the plans suitable for use in areas with bicycle traffic per City Standard Plans

2.4 PORTLAND CEMENT CONCRETE

- A. Concrete shall conform to Section 90 of the CDT standard Specifications.
- B. Cement shall be Type II cement conforming to ASTM Designation C150 as modified by Section 90 of the CDT Standard Specifications.
- C. Aggregate shall be 3/4" maximum size conforming to Section 90 of the CDT Standard Specifications.
- D. Water shall be clear and free from injurious amounts of oil, acid, alkali, organic matter or other deleterious substances.
- E. Reinforcing bars shall conform to the requirements of ASTM A615 Grade 40 and deformed in accordance with Section 52 of the CDT Standard Specifications.

2.5 BEDDING MATERIAL FOR STORM DRAIN PIPING

- A. Storm drain pipe bedding material shall be granular in nature with a minimum durability index of 30 and comply with the gradation requirements listed in the table below:

Sieve Sizes	Percentage Passing
1"	100
3/4"	90-100
3/8"	20-55
#4	0-10
#8	0-5

- B. See the Geotechnical Report provided by BSK Associates dated March 1, 2017 for pipe bedding compaction requirements.
- C. See City of Oakley Standard Plan SD-03 and SD-04 for additional trenching notes.

2.6 SUBSEQUENT BACKFILL MATERIAL FOR STORM DRAIN PIPING

- A. Native on-site soil shall be used as subsequent backfill material complying with the geotechnical report provided by BSK Associates dated March 1, 2017.
- B. The native backfill material shall be free of vegetation, organic materials, debris and refuse, and any other deleterious matter.
- C. The native backfill material shall not contain concrete, stones or clods larger than 3 inches in any dimension and shall contain sufficient fines to fill voids and ensure compaction requirements are met.
- D. A BSK representative should be present on-site during grading to visually confirm the suitability of the on-site soil to be used as fill and backfill, especially the existing stockpile material.
- E. If the native on-site soil is determined to be non-suitable for trench backfill material, then 3/4" maximum class 2 aggregate base complying with Caltrans Standard Specifications Section 26 shall be used as backfill material.
- F. See the Geotechnical Report provided by BSK Associates dated March 1, 2017 for backfill compaction requirements.

2.7 BIORETENTION AREAS

- A. Permeable Material shall be class 2 and comply with Section 68, "Subsurface Drains" of the CDT Standard Specifications.
- B. Bioretention soil mix shall comply with the requirements set forth by Provision C.3. of the Municipal Regional Stormwater Permit (MRP).
- C. See landscape plans for bioretention planting and vegetation.

PART 3 - EXECUTION

3.1 STORM DRAIN PIPE INSTALLATION

- A. Storm drain piping shall be installed in conformance with the City of Oakley Standard Plans SD-03 and SD-04.

3.2 BIORETENTION AREAS

- A. Excavate trenches for PVC pipe as indicated on the plans. When not indicated, excavate to a width equal to the outside diameter of the pipe plus 12 inches and to a depth of 2 inches minimum below the grade established for the invert of the pipe.
- B. Lay pipe to line and grade indicated. If pipe is of the bell-and-spigot type, lay bells in crosscuts cut in trench. Lay pipe with bell end uphill.
- C. Fill space below the pipe invert with a layer of permeable material as indicated, upon which the pipe shall be laid with perforations down. Sections shall be joined with sleeve couplings furnished by the pipe manufacturer or other appropriate method as determined by the pipe-ends configuration and approved by the Engineer. Employ appropriate equipment to draw pipe sections together.
- D. Rocks, bricks, broken concrete or asphalt shall not be used to give intermediate support to pipes. Large stones or other hard objects shall not be left in contact with the pipes.
- E. Fill excavations for underdrains with drainage or filter aggregates as indicated. Place drainage aggregate and compact as required to fill voids and prevent settlement, without damaging the underdrain pipe.

PART 4 - MEASUREMENT AND PAYMENT

4.1 MEASUREMENT

- A. All work involved with BASE BID ITEMS including but not limited to installing PVC STORM DRAIN PIPE, STORM DRAIN CLEANOUTS, AREA DRAINS, and BIORETENTION AREAS will be measured "each" complete in place, unless otherwise specified in the Contract Documents.

- B. All work involved with both BASE BID and ADD ALTERNATE #1 ITEMS, including but not limited to CATCH BASINS and PVC PERFORATED PIPE, will be measured by “each” complete in place, unless otherwise specified in the Contract Documents.

4.2 PAYMENT

- A. All PVC STORM DRAIN PIPE shall be at the cost indicated in the Bid Schedule. The contract prices paid per linear foot for all pvc storm drain pipe shall include, but not limited to, furnishing all labor, materials, tools, equipment and incidentals required for doing all the work involved with placing new pvc storm drain pipe, including trenching excavation, compaction, backfill, pipe connections and fittings, permits, cleaning, deflection testing, pipeline leakage testing, inspection and pavement restoration to finish grade, as shown on the Plans, as specified in the Standard Specifications, these Technical Specifications and the Special Provisions, and as directed by the Engineer. Additionally, no payment will be made for work, equipment, or materials not covered in these plans and specifications, but necessary to insure a completed project as specified.
- B. All PVC PERFORATED PIPE shall be at the cost indicated in the Bid Schedule. The contract prices paid per linear foot for all pvc perforated pipe shall include, but not limited to, furnishing all labor, materials, tools, equipment and incidentals required for doing all the work involved with placing new pvc perforate pipe, including trenching excavation, compaction, backfill, pipe connections and fittings, permits, cleaning, inspection and pavement restoration to finish grade, as shown on the Plans, as specified in the Standard Specifications, these Technical Specifications and the Special Provisions, and as directed by the Engineer. Additionally, no payment will be made for work, equipment, or materials not covered in these plans and specifications, but necessary to insure a completed project as specified.
- C. STORM DRAIN CLEANOUTS shall be at the cost indicated in the Bid Schedule. The contract unit price paid each for new storm drain cleanouts shall include, but not limited to, full compensation for furnishing all labor, supervision, materials, tools, equipment, and incidentals required for doing all the work involved with placing new storm drain cleanout, including excavation, backfill, pipe connections and fittings, cleaning, inspection and pavement restoration to finish grade, as shown on the Plans, as specified in the Standard Specifications, these Technical Specifications and the Special Provisions, and as directed by the Engineer. Additionally, no payment will be made for work, equipment, or materials not covered in these plans and specifications, but necessary to insure a completed project as specified.
- D. NEW CATCH BASINS, DRAIN INLETS, AND AREA DRAINS shall be at the cost indicated in the Bid Schedule. The contract unit prices paid each for new catch basins, drain inlets, and area drains shall include, but not limited to, full compensation for furnishing all labor, supervision, materials, tools, equipment, and incidentals required for doing all the work involved with placing new catch basins, drain inlets, and area drains, including compaction, excavation, backfill, hydrostatic pressure test, cleaning, inspection and pavement restoration to finish grade, as shown on the Plans, as specified in the Standard Specifications, these Technical Specifications and the Special Provisions, and as directed by the Engineer. Additionally, no payment will be made for work, equipment, or materials not covered in these plans and specifications, but necessary to insure a completed project as specified.

- E. **BIORETENTION AREAS** shall be at the price indicated in the Bid Schedule. The contract lump sum price paid for bioretention areas shall include, but not limited to full compensation for furnishing all labor, materials, tools, equipment, and incidentals required for doing all the work involved in constructing the bioretention areas, including compaction, excavation and backfill, class 2 permeable drain rock, bioretention soil mix, planting, moisture barrier liner, curb retaining walls and lateral bracing walls complete in place, as shown on the Plans, as specified in the Standard Specifications, there Technical Specifications and the Special Provisions, and as directed by the Engineer. Additionally, no payment will be made for work, equipment, or materials not covered in these plans and specifications, but necessary to insure a completed project as specified.

END OF SECTION

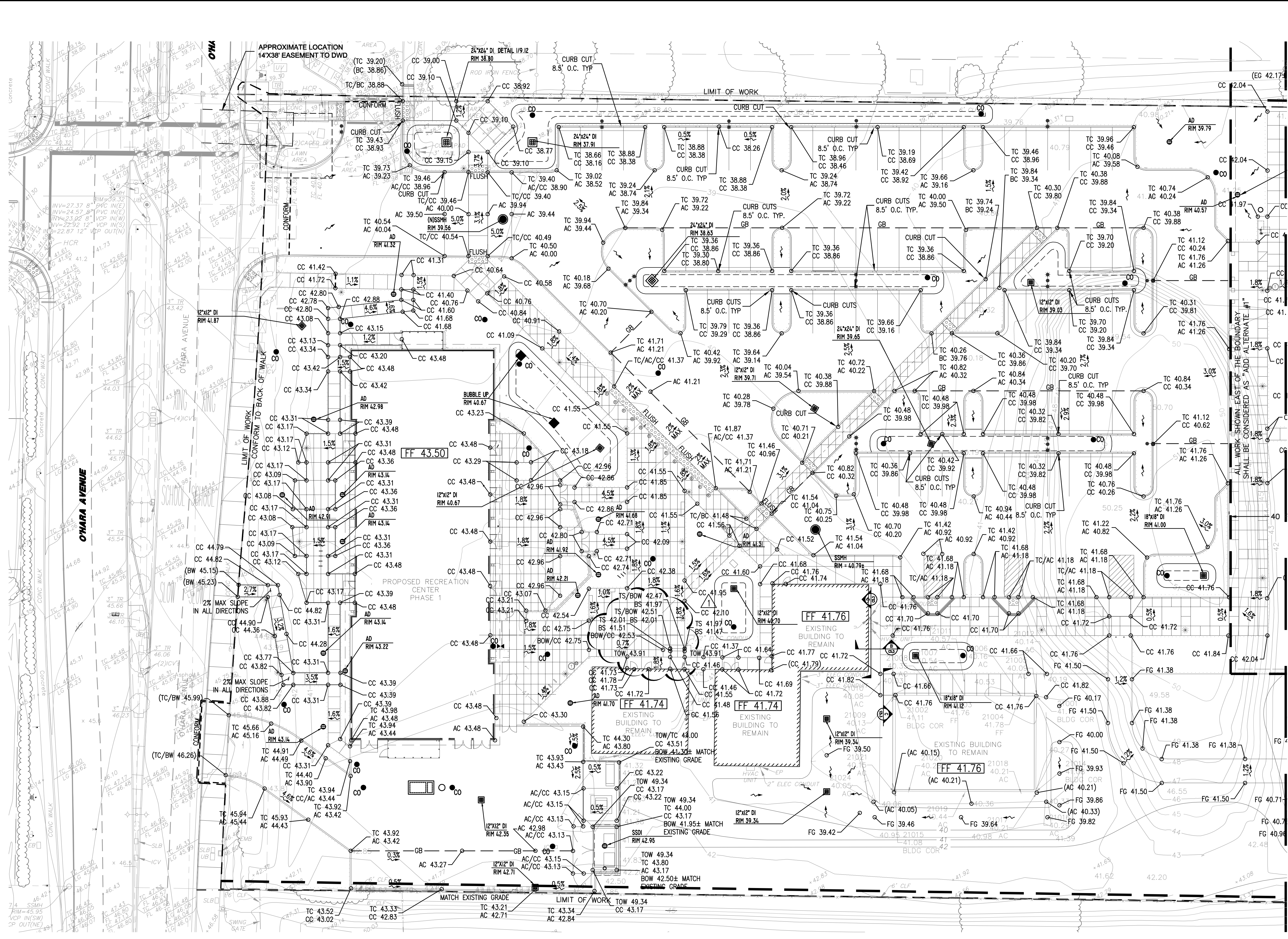

LEGEND
 --- GRADE BREAK
 --- LIMIT OF WORK
 --- CONFORM

- GRADING NOTES**
- ALL ADA PATH OF TRAVELS SHALL HAVE A MAXIMUM CROSS SLOPE OF 2.0% AND A MAXIMUM LONGITUDINAL SLOPE OF 5.0%.
 - VERTICAL CHANGE IN FRONT OF BUILDING ENTRANCES SHALL NOT EXCEED 1/4" WITHOUT EDGE TREATMENT. 1/4" MAX VERTICAL OFFSET ALONG ALL PATHS OF TRAVEL WHICH INCLUDE ALL DOORS, LANDINGS, WALK WAYS, PATIO AREAS AND ALIKE
 - SLOPE OF EXTERIOR PAVING SHALL NOT EXCEED 1/4" PER FOOT (2%) UP TO DOOR'S THRESHOLD FOR A MINIMUM DISTANCE OF 5 FEET OUT FROM THE EXTERIOR DOOR OPENINGS
 - SEE SHEET C4.0 FOR UTILITY STRUCTURE RIM ELEVATIONS.
 - BASE BID:** EXISTING STOCKPILED MATERIAL SHALL BE USED ON-SITE AS BACKFILL TO MEET THE PROPOSED SUBGRADE ELEVATIONS BASED ON THE ORDER OF WORK LISTED BELOW
 - BUILDING SITE (1ST PRIORITY)
 - PARKING LOT (2ND PRIORITY)
 - STOCKPILE IN FIELD (3RD PRIORITY)
 - ADD ALTERNATE #1:** EXISTING STOCKPILED MATERIAL SHALL BE USED ON-SITE AS BACKFILL TO MEET THE PROPOSED SUBGRADE ELEVATIONS BASED ON THE ORDER OF WORK LISTED BELOW
 - BUILDING SITE (1ST PRIORITY)
 - PARKING LOT (2ND PRIORITY)
 - STOCKPILE IN FIELD (3RD PRIORITY)
- SEE SPECIFICATION SECTION 31 10 00 SITE PREPARATION FOR ADDITIONAL ROUGH GRADING INFORMATION
- CONSTRUCTION EQUIPMENT SHALL NOT BE ALLOWED TO DRIVE OVER OR COMPACT THE BOTTOM OF BIOHAZARDS AND INFILTRATION BASINS
 - SEE SHEET C5.3 FOR ADA PARKING STALL SLOPES AND SPOT ELEVATIONS

ABBREVIATIONS

AC ASPHALT CONCRETE
 BS BOTTOM OF STEP
 BOW BOTTOM OF WALL
 BW BACK OF WALK
 CC CONCRETE PAVEMENT
 EG EXISTING GRADE
 FF FINISH FLOOR
 FG FINISHED GRADE
 GB GRADE BREAK
 TC TOP OF CURB
 TOW TOP OF WALL
 TS TOP OF STEP

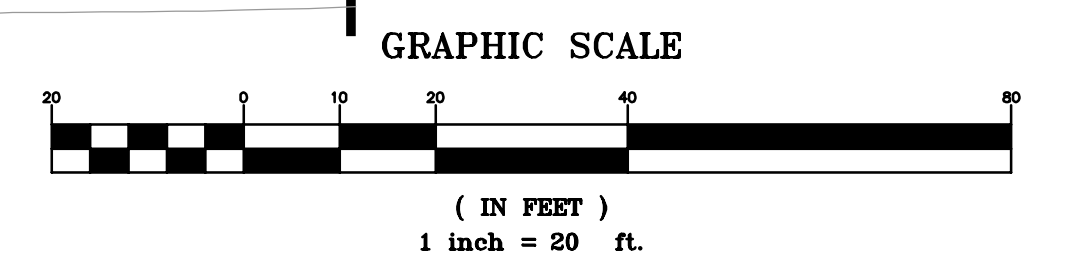
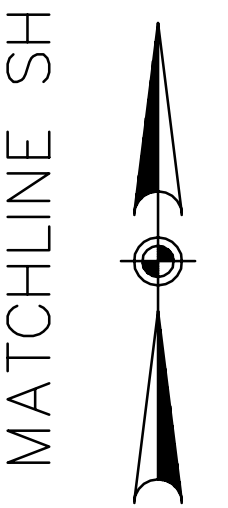

4670 WILLOW RD
 SUITE 250
 PLEASANTON, CA 94566
 925-396-7700
 925-396-7799 (FAX)

REGISTERED PROFESSIONAL ENGINEER
 CIVIL
 STATE OF CALIFORNIA
 No. 77988

OAKLEY RECREATION CENTER
 CONTRA COSTA COUNTY CALIFORNIA
 OAKLEY

ISSUE
 RE-BID SET
 AS NOTED
 DESIGN SR
 DRAWN AR
 APPROVED JL
 DATE: 02/22/18
 02/14/18
 02/22/18
 4
 JOB NO: 17-005

DRAWING NUMBER:

T.O. MIRROR
7'-0" A.F.F.

1
A9.7

1/4" ANGLE
BRACKET

BACKSPLASH

3/4" PLY WD
UNDERLAYMENT

LAV

TRAP WRAPPED
W/ INSUL.

MIRROR

SEALANT
APPLIED TO
BASE OF
MIRROR

COUNTER

1"x3" STL. TUBE,
PAINTED; SEE
1/A9.7 FOR
SUPPORT PLAN

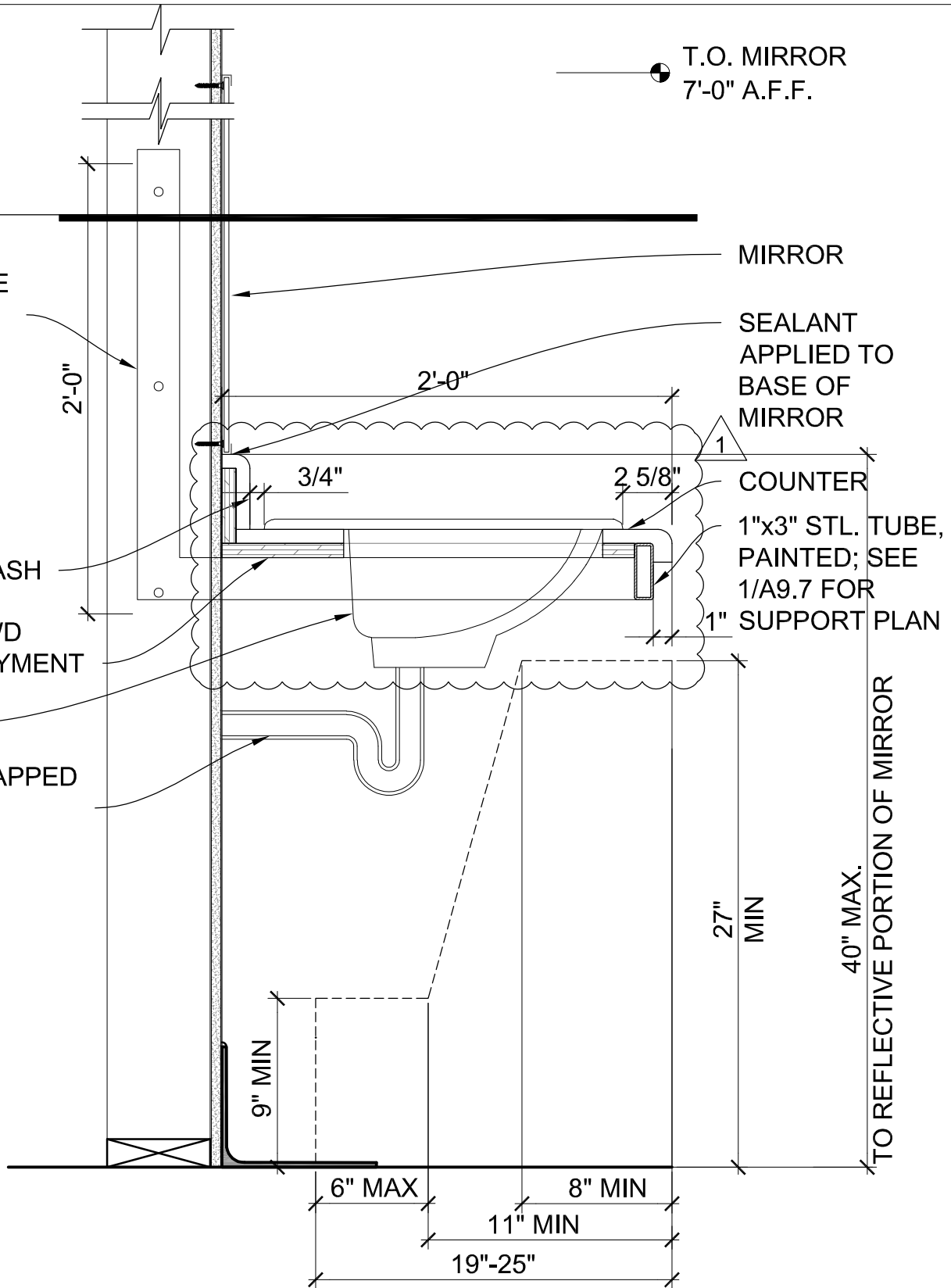

TO REFLECTIVE PORTION OF MIRROR
40" MAX.

27" MIN

9" MIN

6" MAX

11" MIN

8" MIN

19"-25"

SEE 1/A9.7 FOR
PLAN DETAIL

2

RESTROOM COUNTER SECTION

A9.7 SCALE: 1-1/2" = 1'-0"

SIEGEL & STRAIN Architects
6201 Doyle Street Suite B
Emeryville, CA 94608
510 / 547-8092
www.siegelstrain.com

Oakley Recreation Center
Oakley, Contra Costa County, CA

Reference: 2/A9.7

Issued With: Addendum #1

Drawn By: CS

Issue Date: 02/22/2018

AD1
ASK-
01

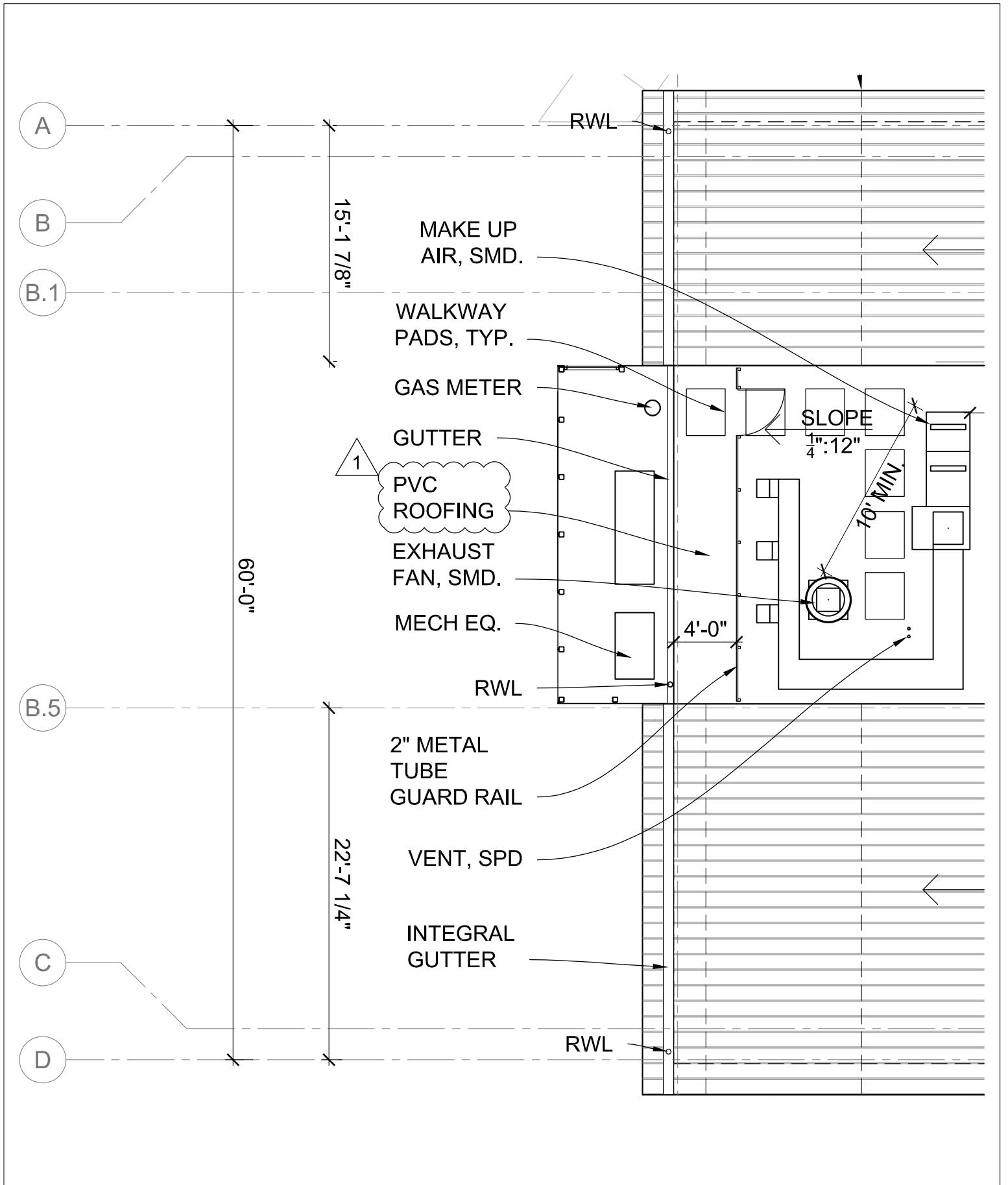

SIEGEL & STRAIN Architects
 6201 Doyle Street Suite B
 Emeryville, CA 94608
 510 / 547-8092
 www.siegelstrain.com

Oakley Recreation Center
 Oakley, Contra Costa County, CA

Reference: 1/A2.3

Issued With: Addendum #1

Drawn By: CS

Issue Date: 02/22/2018

AD1
ASK-
02a

NOTE: ROOF ASSEMBLY R-VALUE: R-46

UNVENTED ROOF ASSEMBLY CONFORMS TO CBC 1203.3-5.1.2. AIR PERMEABLE INSULATION SHALL BE INSTALLED DIRECTLY UNDER THE STRUCTURAL SHEATHING, RIGID BOARD OR SHEET INSULATION SHALL BE INSTALLED DIRECTLY ABOVE THE STRUCTURAL ROOF SHEATHING.

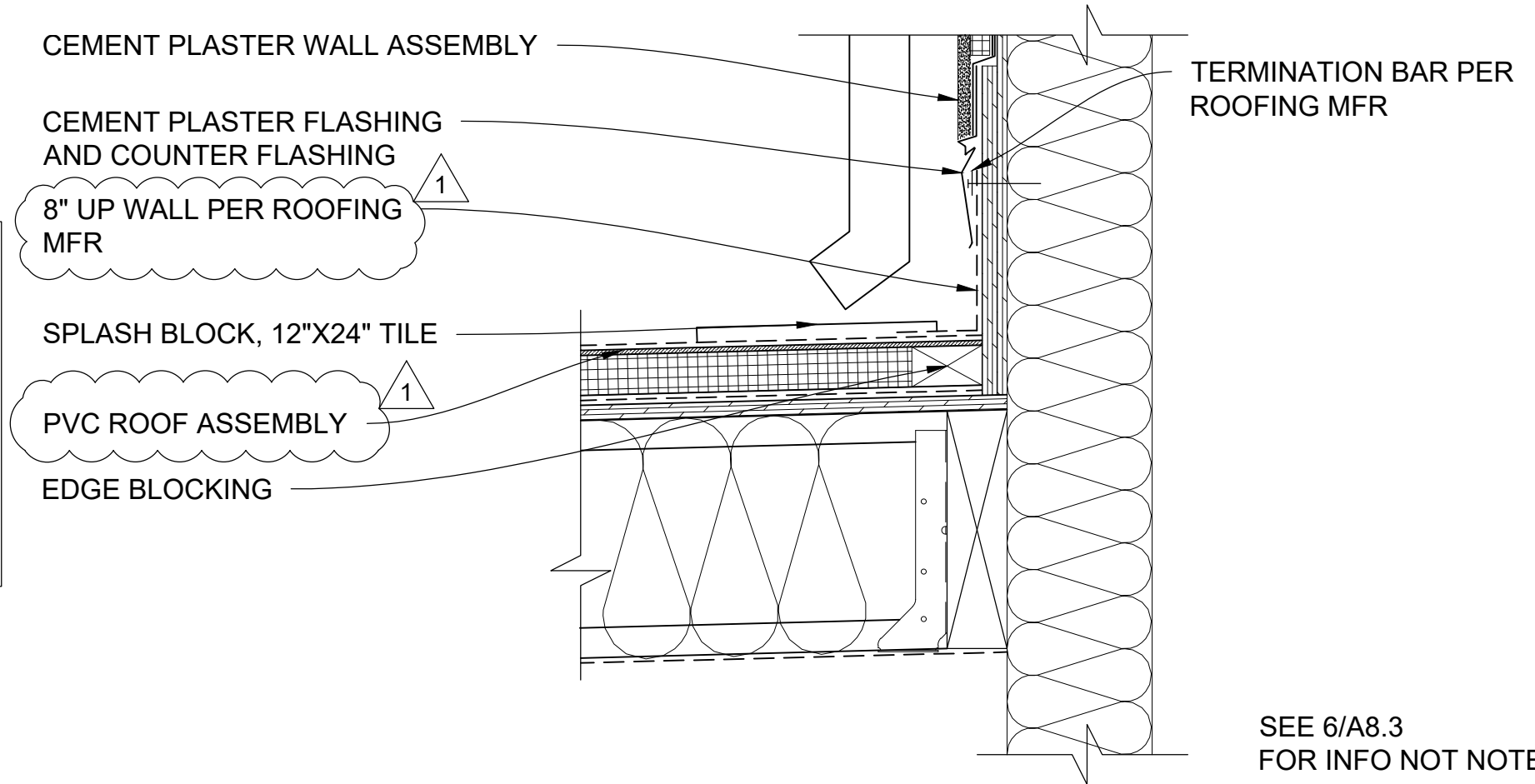

SEE 6/A8.3 FOR INFO NOT NOTED

3 FLAT ROOF AT WALL
A8.3 SCALE: 1-1/2" = 1'-0"

SIEGEL & STRAIN Architects 6201 Doyle Street Suite B Emeryville, CA 94608 510 / 547-8092 www.siegelstrain.com	Oakley Recreation Center Oakley, Contra Costa County, CA		AD1 ASK- 02b
	Reference: 3/A8.3	Issued With: Addendum #1	
	Drawn By: CS	Issue Date: 02/22/2018	

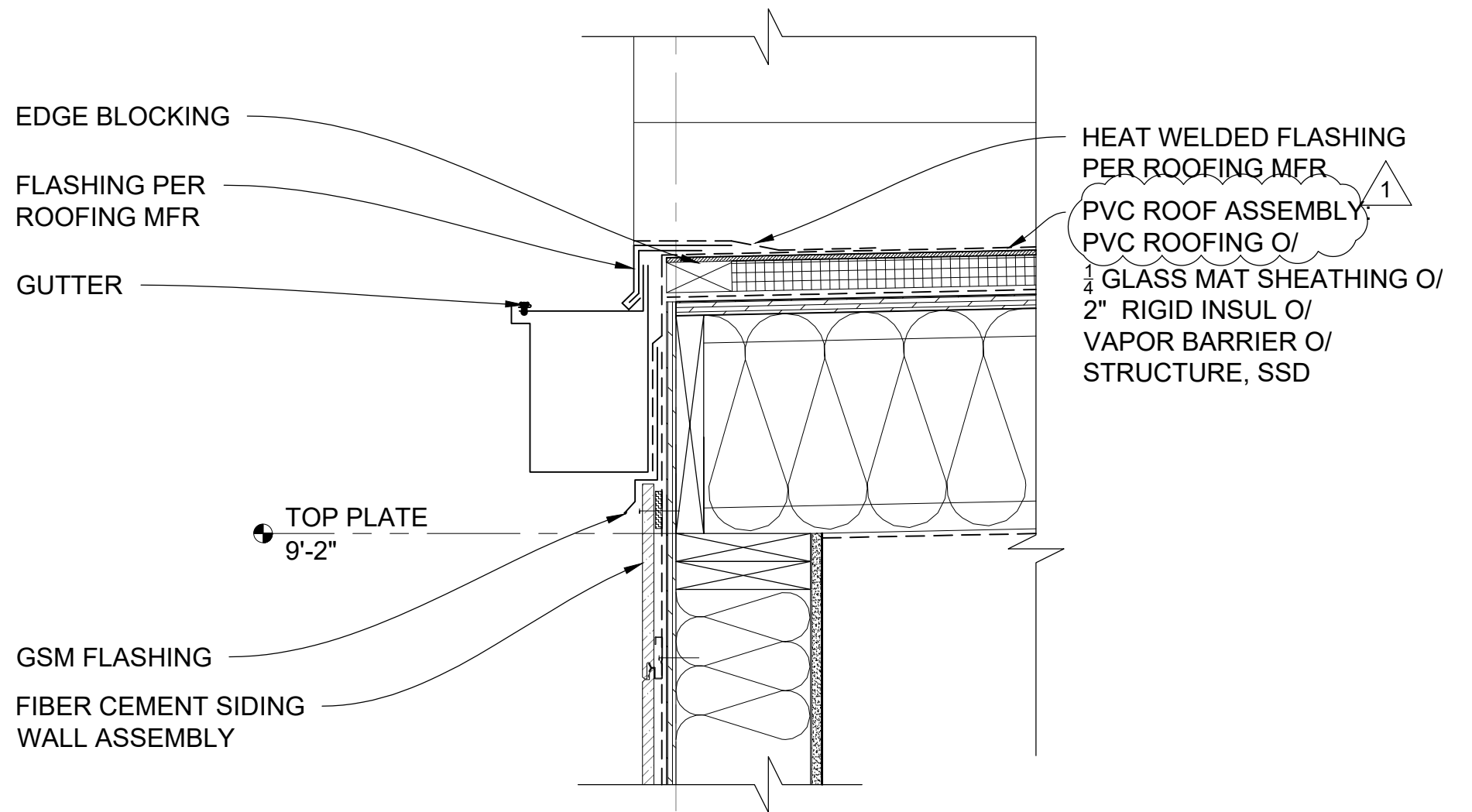

6 ROOF EAVE AT FLAT ROOF
 A8.3 SCALE: 1-1/2" = 1'-0"

SIEGEL & STRAIN Architects 6201 Doyle Street Suite B Emeryville, CA 94608 510 / 547-8092 www.siegelstrain.com	Oakley Recreation Center Oakley, Contra Costa County, CA		AD1 ASK- 02c
	Reference: 6/A8.3	Issued With: Addendum #1	
	Drawn By: CS	Issue Date: 02/22/2018	

GENERAL NOTES

- BEFORE COMMENCEMENT OF WORK, THE CONTRACTOR SHALL VERIFY THE EXACT LOCATIONS, ELEVATIONS AND CHARACTERISTICS OF ALL UTILITIES AND PIPING, AND SHALL IMMEDIATELY NOTIFY THE ARCHITECT OF ANY DISCREPANCIES.
- EXACT LOCATIONS AND MOUNTING HEIGHTS OF PLUMBING FIXTURES SHALL BE OBTAINED FROM THE ARCHITECTURAL DRAWINGS. SEE ARCHITECTURAL DRAWINGS FOR ADA FIXTURE LOCATIONS AND MOUNTING HEIGHTS. (INSULATE ALL EXPOSED HOT AND COLD WATER AND DRAIN PIPING BELOW ADA LAVATORIES AND SINKS AND OFFSET P-TRAP AGAINST WALL. ALSO, ALL FLUSH VALVES SHALL BE TO WIDE SIDE OF STALL.)
- TRAPS FOR ALL LAVATORIES AND SINKS SHALL TRAP STRAIGHT BACK TO WALL WITH ALL REQUIRED OFFSETS HAPPENING WITHIN THE WALL. THE CONTRACTOR SHALL MAKE ALL ARRANGEMENTS WITH UTILITY COMPANIES FOR SERVICE IN THE NAME OF THE OWNER AND SHALL PAY ALL MATERIAL AND LABOR COSTS INCIDENTAL TO AN OPERABLE UTILITY SERVICE AS REQUIRED BY THE DESIGNATED GOVERNING AUTHORITIES OF THE CITY.
- ALL PLUMBING WORK SHALL BE INSTALLED SO AS TO AVOID INTERFERENCE WITH ELECTRICAL AND MECHANICAL EQUIPMENT AND STRUCTURAL FRAMING.
- THE CONTRACTOR SHALL COORDINATE THE LOCATION OF ALL CEILING ACCESS PANELS WITH THE ARCHITECTURAL REFLECTED CEILING PLANS AND THE ELEC. LIGHTING LAYOUT.
- THE PLUMBING CONTRACTOR SHALL PROVIDE THE WATER, SEWER AND STORM DRAIN SYSTEMS TO A POINT OF CONNECTION SHOWN ON FLOOR PLANS AND SHALL MEET THE INVERT ELEVATION AS FIELD VERIFIED WHILE MAINTAINING REQUIRED PIPE GRADE.
- ANY ALTERATIONS TO A STRUCTURAL MEMBER, SUCH AS CUTTING, BORING, BRAZING, DRILLING, WELDING, ETC. SHALL HAVE PRIOR WRITTEN APPROVAL OF ARCHITECT AND STRUCTURAL ENGINEER.
- ALL CLEANOUTS SHALL BE INSTALLED WHERE READILY ACCESSIBLE. THE CONTRACTOR SHALL COORDINATE ALL CLEANOUT LOCATIONS WITH EQUIPMENT, CABINETS, ETC., AND THE ARCHITECT PRIOR TO ANY INSTALLATION.
- CONTRACTOR TO PROVIDE WATER HAMMER ARRESTORS AS MANUFACTURED BY JAY R. SMITH. WATER HAMMER ARRESTORS SHALL BE INSTALLED PER MANUFACTURER'S RECOMMENDATIONS ON ALL DOMESTIC WATER BRANCH LINES SERVING FIXTURES.
- ALL PLUMBING FIXTURE VENTS TO TERMINATE A MIN. OF 12 INCHES FROM ANY VERTICAL SURFACE AND 10 FEET FROM ANY OUTSIDE AIR INTAKES.
- ALL VALVES, UNIONS, ETC. TO BE SAME SIZE AS PIPE UNLESS OTHERWISE INDICATED ON DRAWINGS.
- CONTRACTOR SHALL COORDINATE LAYOUT OF ALL BELOW GRADE PIPING AND COMPONENTS WITH GENERAL CONTRACTOR PRIOR TO BID TO DETERMINE EXTENT OF REQUIRED SAW CUTTING, EXCAVATION, AND SUBSEQUENT REPAIR/RESTORATION OF ALL AFFECTED HARDSCAPE AND SOFTSCAPE SURFACES. ALL SUCH ITEMS SHALL BE INCLUDED IN BID.
- BEFORE FABRICATION OR INSTALLATION THE CONTRACTOR SHALL VERIFY EXACT LOCATIONS OF ALL MECHANICAL EQUIPMENT AND EQUIPMENT PROVIDED UNDER ANOTHER SECTION OF SPECIFICATIONS. EXACT ROUGH-IN LOCATIONS AND REQUIREMENTS SHALL BE COORDINATED IN FIELD.
- ALL POINTS OF CONNECTION SHALL BE COORDINATED WITH THE GENERAL CONTRACTOR PRIOR TO BID.
- ALL WASTE AND VENT PIPING SHALL SLOPE AT 2% UNLESS OTHERWISE INDICATED.
- ALL VALVES, WATER HAMMER ARRESTORS OR OTHER EQUIPMENT SHOWN IN WALLS OR ABOVE NON-ACCESSIBLE CEILINGS SHALL BE INSTALLED BEHIND AN ACCESS PANEL.
- THESE DRAWINGS SHALL BE READ IN CONJUNCTION WITH AND BE CONSIDERED TO BE A PART OF SEPARATE AND COMPLETE MECHANICAL SPECIFICATIONS.
- CONNECTION BETWEEN INCOMPATIBLE MATERIALS ABOVE GRADE AND INSIDE BUILDING SHALL BE MADE WITH TWO (2) DIELECTRIC UNIONS SEPARATED BY A SIX INCH (6") SECTION OF RED BRASS PIPE.
- ALL EXTERIOR GAS COCKS, WATER SHUT OFF VALVES AND/OR SEWER CLEANOUTS BELOW GROUND SHALL BE INSTALLED IN YARD BOXES WITH THE COVERS CONSPICUOUSLY MARKED "GAS", "WATER", AND "SEWER" RESPECTIVELY.
- THE CONTRACTOR SHALL VERIFY THE EXACT ELEVATIONS AND LOCATION OF EXISTING DRAINAGE SYSTEM PIPING PRIOR TO CONNECTION OF ANY PIPING.
- ALL HORIZONTAL PIPING LINES EXTENDED AND CONNECTED TO EQUIPMENT SHALL BE RUN AT THE HIGHEST POSSIBLE ELEVATIONS AND NOT LESS THAN 6" ABOVE THE FLOOR TO PROVIDE CLEARANCE FOR CLEANING. AT WALL OR COLUMN LOCATIONS, PIPING ROUGH-IN SHALL BE STUBBED IN WALLS WHENEVER POSSIBLE.
- THE CONTRACTOR SHALL BE RESPONSIBLE FOR PATCHING AND REPAIRING ALL AREAS WHICH ARE DAMAGED BY HIS OPERATIONS. IN ADDITION, THE CONTRACTOR SHALL RESTORE TO THEIR ORIGINAL CONDITION ALL EXISTING STRUCTURE AND NEW CONSTRUCTION DAMAGED BY HIS OPERATIONS.
- THE CONTRACTOR SHALL BE RESPONSIBLE FOR PATCHING AND REPAIRING ALL PAVED AREAS WHICH ARE EXCAVATED AND/OR DAMAGED BY HIS OPERATIONS. IN ADDITION, THE CONTRACTOR SHALL RESTORE TO THEIR ORIGINAL CONDITION ALL PLANTED AREAS DAMAGED BY HIS OPERATIONS.
- ALL PATCHING AND REPAIRING OF CONCRETE PAVING AND/OR WALKS SHALL BE UNDER ANOTHER SECTION OF THE SPECIFICATIONS.
- ALL EXISTING PIPING DAMAGED DURING EXCAVATION SHALL BE REPAIRED WITH MATERIALS TO MATCH EXISTING BY THE CONTRACTOR AT NO COST TO THE OWNER.
- ALL CUTTING OF EXISTING PAVING, WALKS AND/OR FLOORS SHALL BE BY MACHINE SAW CUTTING. HOLES FOR PIPES IN CONCRETE WALLS OR FLOORS SHALL BE DONE BY CORE DRILLING EQUIPMENT.
- ALL PIPING, EXCEPT PIPING OF NONFERROUS MATERIAL, INSTALLED WITHIN THE GROUND SHALL BE PROTECTED AGAINST CORROSION BY A PROTECTIVE COVERING SUITABLE FOR THE PURPOSE AND SUBJECT TO THE APPROVAL OF THE BUILDING OFFICIAL. ANY PIPING SUBJECT TO UNDUE CORROSIVE ACTION SHALL BE PROTECTED IN A MANNER SUITABLE FOR THE PURPOSE AND SUBJECT TO THE APPROVAL OF THE BUILDING OFFICIAL.
- ALL PENETRATIONS AND OPENINGS IN PARTY WALLS AND ROOF/FLOOR/CEILING ASSEMBLIES DUE TO PLUMBING WORK SHALL BE SEALED LINED, INSULATED OR OTHERWISE TREATED TO MAINTAIN THE REQUIRED FIRE AND SOUND RATING.

M/E/P COMPONENT ANCHORAGE NOTES

ALL MECHANICAL, PLUMBING, AND ELECTRICAL COMPONENTS SHALL BE ANCHORED OR INSTALLED PER THE DETAILS ON THE DSA APPROVED CONSTRUCTION DOCUMENTS. WHERE NO DETAIL IS INDICATED, THE FOLLOWING COMPONENTS SHALL BE ANCHORED OR BRACED TO MEET THE FORCED AND DISPLACEMENT REQUIREMENTS PRESCRIBED IN THE 2016 CBC, SECTIONS 1616A.1.23 THROUGH 1616A.1.26 AND ASCE 7-10 CHAPTER 26 AND 13.

- ALL PERMANENT EQUIPMENT AND COMPONENTS.
- TEMPORARY OR MOVABLE EQUIPMENT THAT IS PERMANENTLY ATTACHED (E.G. HARD WIRED) TO THE BUILDING UTILITY SERVICES SUCH AS ELECTRICITY, GAS OR WATER.
- MOVABLE EQUIPMENT WHICH IS STATIONED IN ONE PLACE FOR MORE THAN 8 HOURS AND HEAVIER THAN 400 POUNDS ARE REQUIRED TO BE ANCHORED WITH TEMPORARY ATTACHMENTS.

THE ATTACHMENT OF THE FOLLOWING MECHANICAL AND ELECTRICAL COMPONENTS SHALL BE POSITIVELY ATTACHED TO THE STRUCTURE, BUT NEED NOT BE DETAILED ON THE PLANS. THESE COMPONENTS SHALL HAVE FLEXIBLE CONNECTIONS PROVIDED BETWEEN THE COMPONENT AND ASSOCIATED DUCTWORK, PIPING AND CONDUIT.

A. COMPONENTS WEIGHING LESS THAN 400 POUNDS AND HAVE A CENTER OF MASS LOCATED 4 FEET OR LESS ABOVE THE ADJACENT FLOOR OR ROOF LEVEL THAT DIRECTLY SUPPORT THE COMPONENT.

B. COMPONENTS WEIGHING LESS THAN 20 POUNDS, OR IN THE CASE OF DISTRIBUTED SYSTEMS, LESS THAN 5 POUNDS PER FOOT, WHICH ARE SUSPENDED FROM A ROOF OR FLOOR OR HUNG FROM A WALL.

FOR THOSE ELEMENTS THAT DO NOT REQUIRE DETAILS ON THE APPROVED DRAWINGS, THE INSTALLATION SHALL BE SUBJECT TO THE APPROVAL OF THE STRUCTURAL ENGINEER OF RECORD AND THE DSA DISTRICT STRUCTURAL ENGINEER. THE PROJECT INSPECTOR WILL VERIFY THAT ALL COMPONENTS AND EQUIPMENT HAVE BEEN ANCHORED IN ACCORDANCE WITH ABOVE REQUIREMENTS.

PIPING DISTRIBUTION BRACING NOTES

PIPING, DUCTWORK, AND ELECTRICAL DISTRIBUTION SYSTEMS SHALL BE BRACED TO COMPLY WITH THE FORCES AND DISPLACEMENTS PRESCRIBED IN ASCE 7-10 SECTION 13.3 AS DEFINED IN ASCE 7-10 SECTION 13.6.8, 13.6.7 AND 13.6.5.6 AND 2016 CBC SECTION 1616A.1.23, 1616A.1.24, 1616A.1.25 AND 1616A.1.26.

THE BRACING AND ATTACHMENTS TO THE STRUCTURE SHALL BE DETAILED ON THE APPROVED DRAWINGS OR THEY SHALL COMPLY WITH ONE OF THE OSHPD PRE-APPROVAL OF MANUFACTURER'S CERTIFICATIONS (OPM) AS MODIFIED TO SATISFY ANCHORAGE REQUIREMENTS OF ACI 318-11, APPENDIX D.

COPIES OF THE OPM MANUAL(S) SHALL BE AVAILABLE ON THE JOB SITE PRIOR TO THE START OF HANGING AND BRACING OF THE PIPE, DUCTWORK, AND ELECTRICAL DISTRIBUTION SYSTEMS.

THE STRUCTURAL ENGINEER OF RECORD SHALL VERIFY THE ADEQUACY OF THE STRUCTURE TO SUPPORT THE HANGER AND BRACE LOADS.

PLUMBING LEGEND

SYMBOL	ABBREVIATION	DESCRIPTION
—W—	W	SANITARY WASTE/SEWER PIPING
—GW—	GW	GREASE WASTE PIPING
—SD—	SD	STORM DRAIN PIPING
—OFD—	OFD	OVERFLOW DRAIN PIPING
-----	V	WASTE/SANITARY VENT PIPING
—GV—	GV	GREASE VENT PIPING
		DEMO PIPING
-----	(E)W	EXISTING SANITARY SEWER PIPING
-----	(E)V	EXISTING SANITARY VENT PIPING
-----	CW	DOMESTIC COLD WATER PIPING
-----	HW	DOMESTIC HOT WATER PIPING
-----	HWR	DOMESTIC HOT WATER RETURN PIPING
-----	(E)CW	EXISTING COLD WATER PIPING
-----	(E)HW	EXISTING HOT WATER PIPING
-----	(E)HWR	EXISTING HOT WATER RETURN PIPING
—G—	G	NATURAL GAS PIPING
—MPG—	MPG	MEDIUM PRESSURE NATURAL GAS PIPING
—G—	(E)G	EXISTING NATURAL GAS PIPING
—MPG—	(E)MPG	EXISTING MEDIUM PRESSURE NATURAL GAS PIPING
—CD—	CD	CONDENSATE DRAIN PIPING
c		PIPE GOING DOWN
o		PIPE GOING UP
∩		TEE
⊙	FCO	FLOOR CLEANOUT/CLEANOUT TO GRADE
⊙		P-TRAP
⊙	POC	POINT OF CONNECTION
	WCO	WALL CLEANOUT
⊏		PIPE CAP
⊕	HB	HOSE BIBB
⊕	SOV	SHUT-OFF VALVE
⊕	SOVAP	SHUT-OFF VALVE IN ACCESS PANEL
⊕	SOVYB	SHUT-OFF VALVE IN YARD BOX
⊕		PLUG VALVE
⊕		GAS COCK VALVE
⊕		CHECK VALVE
⊕	FD	FLOOR DRAIN
⊕	FS	FLOOR SINK
XX-X		EQUIPMENT OR FIXTURE
	CONT.	CONTINUED/CONTINUATION
	DFM	DISTANCE FROM METER
	FR.	FROM
	BEL.	BELOW
	DN.	DOWN
	VTR	VENT THROUGH ROOF
	AP	ACCESS DOOR
	NIC	NOT IN CONTRACT
	REF.	REFERENCE
	S.A.D.	SEE ARCHITECTURAL DRAWINGS
	S.M.D.	SEE MECHANICAL DRAWINGS
	S.C.D.	SEE CIVIL DRAWINGS
	S.S.D.	SEE STRUCTURAL DRAWINGS
	SF	SQUARE FEET

PLUMBING FIXTURE SCHEDULE

FIXTURE	MARK	ROUGH IN CONNECTIONS				DESCRIPTION
		HW	CW	WASTE	VENT	
WATER CLOSET	WC-1	--	1"	4"	2"	AMERICAN STANDARD MADERA FLOWISE 3451.001 FLOOR MOUNTED WATER CLOSET WITH EVERCLEAN, ELONGATED BOWL, VITREOUS CHINA, 1-1/2" TOP SPUD, POWERFUL DIRECT-FED SIPHON JET ACTION. FLUSH VALVE: SLOAN CROWN 111-1.28 PISTON OPERATED, CHROME PLATED, HIGH EFFICIENCY 1.28 GPF. TOILET SEAT: BEMIS 1955CT OPEN FRONT LESS COVER, ELONGATED, HEAVY DUTY, INJECTION MOLDED SOLID PLASTIC. CARRIER: SEE SECTION 22 00 00.
WATER CLOSET (ADA)	WC-2	--	1"	4"	2"	AMERICAN STANDARD MADERA FLOWISE 3461.001 FLOOR MOUNTED WATER CLOSET WITH EVERCLEAN, ELONGATED BOWL, VITREOUS CHINA, 1-1/2" TOP SPUD, POWERFUL DIRECT-FED SIPHON JET ACTION. FLUSH VALVE: SLOAN CROWN 111-1.28 PISTON OPERATED, CHROME PLATED, HIGH EFFICIENCY 1.28 GPF. TOILET SEAT: BEMIS 1955CT OPEN FRONT LESS COVER, ELONGATED, HEAVY DUTY, INJECTION MOLDED SOLID PLASTIC. CARRIER: SEE SECTION 22 00 00.
URINAL	UR-1	--	3/4"	2"	2"	AMERICAN STANDARD 6590.001 WASHBROOK WALL MOUNTED, VITREOUS CHINA, WASHOUT FLUSH ACTION, 3/4" TOP SPUD. FLUSH VALVE: AMERICAN STANDARD 6047.111.002 EXPOSED FLUSHOMETER 0.125 GPF, DURABLE CHROME-PLATED CAST BRASS CONSTRUCTION, 3/4" TOP SPUD, MANUAL PISTON. CARRIER: SEE SECTION 22 00 00.
URINAL (ADA)	UR-2	--	3/4"	2"	2"	AMERICAN STANDARD 6590.001 WASHBROOK WALL MOUNTED, VITREOUS CHINA, WASHOUT FLUSH ACTION, 3/4" TOP SPUD. FLUSH VALVE: AMERICAN STANDARD 6047.111.002 EXPOSED FLUSHOMETER 0.125 GPF, DURABLE CHROME-PLATED CAST BRASS CONSTRUCTION, 3/4" TOP SPUD, MANUAL PISTON. CARRIER: SEE SECTION 22 00 00.
LAVATORY	L-1	1/2"	1/2"	2"	2"	AMERICAN STANDARD RONDALYN 0491.019 COUNTER MOUNTED 19 1/8" LAVATORY, VITREOUS CHINA, WITH FRONT OVERFLOW. FAUCET: AMERICAN STANDARD 6056.204 ELECTRONIC FAUCET, SOLID BRASS CONSTRUCTION, AC PERMANENT POWER, 0.35 GPM PRESSURE COMPENSATING VANDAL RESISTANT NON-AERATING SPRAY. STRAINER/ANGLE STOPS/P-TRAP/PIPE WRAP. SEE SECTION 22 00 00.
THEMOSTATIC MIXING VALVE	TMV-1	3/4"	3/4"			CHICAGO FAUCET 131 ABNE 3/8" COMPRESSION INLETS AND OULETS, BRASS BODY CONSTRUCTION.
BACKWATER VALVE	BV-1	--	--	4"	--	MIFAB BV1204-R-1 CAST IRON BACKWATER VALVE, NO HUB INLET/OUTLET, GASKETED BOLTED COVER, AUTOMATIC PVC FLAPPER, NICKEL BRONZE ACCESS COVER.
DRINKING FOUNTAIN	DF-1	--	1/2"	2"	2"	ELKAY E2H20 LZWS-EDFP217K BOTTLE FILLER WITH INTEGRAL SOFT SIDES FOUNTAIN, STAINLESS STEEL, ELECTRONIC BOTTLE FILLER SENSOR, FRONT BUBBLER ACTIVATION, 115V/60Hz, 1.0 AMPS. MOUNTING FRAME: ELKAY MFWS200
MOP SINK	MS-1	3/4"	3/4"	3"	2"	FLORESTONE MODEL 85 24"x24"x12" MOP SINK, MOLDED TERRAZZO. FAUCET: AMERICAN STANDARD 8350.243 WALL MOUNTED, CAST BRASS BODY, METAL LEVER HANDLES WITH HOT AND COLD INDICATORS, VANDAL-RESISTANT SCREWS, VACUUM BREAKER, SPOUT WITH BUCKET HOOK AND THREADED HOSE.
FLOOR SINK	FS-1	-	-	SEE PLANS	SEE PLANS	ZURN #Z1910 FLOOR SINK DURA-COATED CAST IRON BODY WITH BOTTOM OUTLET, COMBINATION INVERTIBLE MEMBRANE CLAMP AND ADJUSTABLE COLLAR AND MEDIUM DUTY GRATE.
FLOOR DRAIN	FD-1	-	-	SEE PLANS	SEE PLANS	ZURN #Z415B FLOOR DRAIN DURA-COATED CAST IRON BODY WITH BOTTOM OUTLET, COMBINATION INVERTIBLE MEMBRANE CLAMP AND ADJUSTABLE COLLAR WITH SEEPAGE SLOTS AND "TYPE B" POLISHED NICKEL BRONZE, LIGHT DUTY STRAINER.
HOSE BIBB	HB-1	-	3/4"	-	-	ACORN #8121 3/4" HOSE BIBB FLUSH MOUNT, COMPLETE WITH VACUUM BREAKER.
HOSE BIBB	HB-2	-	3/4"	-	-	ACORN #8104 3/4" HOSE BOX RECESSED WITH CAM LOCK, REMOVABLE LOOSE KEY WHEEL HANDLE, COMPLETE WITH VACUUM BREAKER.
TRAP PRIMER	TP-1	-	1/2"	-	-	PRECISION PLUMBING PRODUCTS P2-500 TRAP PRIMER, CORROSION RESISTANT BRASS, PISTON OPERATED.

NOTES:
 1. ITEM DESCRIPTIONS INCLUDED IN THIS SCHEDULE ARE INTENDED TO DESCRIBE GENERAL FIXTURE CONFIGURATIONS, AND DO NOT INCLUDE ALL REQUIREMENTS. REFER TO SPECIFICATION SECTION 22 00 00 FOR ADDITIONAL REQUIREMENTS.
 2. REFER TO ARCHITECTURAL DRAWINGS FOR MOUNTING HEIGHTS AND REQUIRED CLEARANCES OF ALL FIXTURES.
 3. ALL FIXTURES, TRIM, AND VALVING SHALL COMPLY WITH CALIFORNIA'S LEAD FREE PLUMBING LAW, HEALTH AND SAFETY CODE AND CA ASSEMBLY BILL 1953.

GAS WATER HEATER SCHEDULE

ITEM	MANUFACTURER	MODEL NO.	SERVICE	STORAGE (GAL.)	MBH	VOLT	PHASE	RECOVERY @ 90°F (GAL.)	INLET TEMP (°F)	OUTLET TEMP (°F)	OPERATING WEIGHT (LBS)
GWH-1	AO SMITH	BTL-154	DOMESTIC WATER	81	154	120	1	164	60	140	1548

CIRCULATION PUMP SCHEDULE

ITEM	LOCATION	MANUFACTURER	MODEL NO.	SERVICE	TYPE	ACCESSORIES	CAPACITY		MOTOR			
							GPM	HEAD	HORSE POWER	VOLT	PHASE	AMPS
CP-1	GWH-1	TACO PUMPS	IL-003	HOT WATER RETURN	CARTRIDGE	N/A	1	1	1/40	115	1	0.43

LIST OF APPLICABLE CODES

LIST OF CODES AND STANDARDS MODEL CODE EDITIONS EFFECTIVE JANUARY 1, 2016

2016 CA BUILDING CODE TITLE 24 PART 2 VOLUME #1 AND #2

2016 CA ELECTRICAL CODE TITLE 24 PART 3

2016 CA MECHANICAL CODE TITLE 24 PART 4

2016 CA PLUMBING CODE TITLE 24 PART 5

2016 CA FIRE CODE TITLE 24 PART 9

2016 CA BUILDING STANDARDS TITLE 24 PART 9

SHEET INDEX

P0.1	GENERAL NOTES, LEGEND & SCHEDULES
P0.2	DETAILS
P0.3	DETAILS
P0.4	CALCS & GAS DIAGRAM
P2.0	PLUMBING UNDERFLOOR PLAN
P2.1	PLUMBING FIRST FLOOR PLAN
P2.2	PLUMBING ROOF PLAN
P3.1	PLUMBING PARTIAL FLOOR PLAN

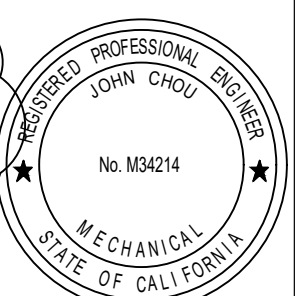

OAKLEY RECREATION CENTER
 CONTRA COSTA COUNTY CALIFORNIA
 OAKLEY
 PLUMBING GENERAL NOTES, LEGEND AND SCHEDULES

No.	Revisions
1	RE-BID SET 02/14/18
4	ADDENDUM 1 02/27/18

Date: 02/22/18
 Scale: NONE
 Design: SCH
 Drawn:
 Approved: JC
 Job No: 17-005

Drawing Number:
P0.1

LUMINAIRE SCHEDULE

LU1 DESCRIPTION: RECESSED LINEAR LED LUMINAIRE WITH EXTRUDED ALUMINUM HOUSING AND MACHINED ALUMINUM END CAPS. WHITE INTERNAL REFLECTOR AND CONTINUOUS HIGH TRANSMISSION FROSTED LENS. NOMINAL 12' LENGTH; NOMINAL 1840 LUMEN OUTPUT PER 4'; CEILING MOUNTING HARDWARE TO BE VERIFIED AS INDICATED ON THE DRAWINGS. 2.25" W X 3.325"H. FLANGE FINISH TO BE DETERMINED BY THE ARCHITECT. WET LOCATION LISTED.

MANUFACTURER: ALIGHT #ACL5-M12'-LS-30-U-HE-XP-FINISH-D-EC-Q
 POWER SUPPLY: INTEGRAL ELECTRONIC SWITCHING POWER SUPPLY
 LIGHT SOURCE: INTEGRAL 3000K LEDS WITH 460 NOMINAL LUMENS PER FT.
 WATTS / VOLTAGE: 60W/120V

LUMINAIRE SCHEDULE

LR1 DESCRIPTION: PENDANT MOUNTED DIRECT/INDIRECT LED LUMINAIRE. STEEL AND ALUMINUM BODY WITH WHITE POWDER COATED STEEL TOP COVER PLATE. THREE STAINLESS STEEL SUSPENSION CABLES WITH DUAL SILVER BRAIDED POWER CABLE AND CANOPIES. SECTIONAL OPAL POLYCARBONATE UP AND DOWNLIGHT DIFFUSERS. 60% DOWNLIGHT AND 40% UPLIGHT. 8" NOMINAL DIAMETER. FINISH TO BE DETERMINED BY THE ARCHITECT. SEPARATE UP/DOWN DIMMING.

MANUFACTURER: BETA CALCO #95 0190-30-S1-FINISH-OD-SS
 POWER SUPPLY: INTEGRAL ELECTRONIC 0-10V DIMMING
 LIGHT SOURCE: INTEGRAL 3000K LEDS WITH 39221 NOMINAL LUMEN OUTPUT
 WATTS / VOLTAGE: 396W/120V

LR2 DESCRIPTION: SIMILAR TO TYPE LR1 EXCEPT 4" DIAMETER AND 25% LUMEN REDUCTION WITH 9483 LUMEN DOWNLIGHT DISTRIBUTION AND 3774 UPLIGHT DISTRIBUTION.

MANUFACTURER: BETA CALCO #95 0170-30-S1-FINISH-PR2-OD-SS
 POWER SUPPLY: INTEGRAL ELECTRONIC 0-10V DIMMING
 LIGHT SOURCE: INTEGRAL 3000K LEDS WITH 13250 NOMINAL LUMEN OUTPUT
 WATTS / VOLTAGE: 135W/120V

LS1 DESCRIPTION: POLE MOUNTED LED AREA LIGHT WITH DIE-CAST LOW COPPER ALUMINUM ALLOY CONSTRUCTION, STAINLESS STEEL FASTENERS AND HARDWARE, AND TOOL-LESS ACCESS. 29" NOMINAL PROJECTION X 15.5" WIDTH X 4" NOMINAL LUMINAIRE HEIGHT. IES TYPE IV OPTICAL DISTRIBUTION WITH SPILL LIGHT CONTROL. DIE-CAST POWER SUPPLY CHAMBER. INTEGRAL ELECTRONIC POWER SUPPLY. SPECIAL POLYESTER POWDERCOAT FINISH TO BE DETERMINED BY THE ARCHITECT. FLUSH MOUNTED TO 4" OUTSIDE DIAMETER, 18" HIGH STRAIGHT ROUND STEEL POLE WITH FULL BASE COVER, HANDHOLE, AND MATCHING FINISH.

MANUFACTURER: MCGRAW EDISON #GLEON-AF-02-LED-E1-SL4-FINISH(Super Durable 038/90015 Pearl Dark Gray)-8030-600-HSS
 POLE: MCGRAW EDISON #RSS-4-M-20'(MOD TO 18')-S-FINISH(Super Durable 038/90015 Pearl Dark Gray)-DRILLING-1
 POWER SUPPLY: INTEGRAL ELECTRONIC SWITCHING POWER SUPPLY
 LIGHT SOURCE: INTEGRAL 3000K LEDS WITH 6000 NOMINAL LUMEN OUTPUT
 WATTS / VOLTAGE: 67W/120V

LS2 DESCRIPTION: SIMILAR TO TYPE LS1 EXCEPT WITH (2) TYPE III DISTRIBUTION HEADS ON A SINGLE POLE AT 180 DEGREES OPPOSING MOUNTING POSITION.

MANUFACTURER: MCGRAW EDISON #(2) GLEON-AF-02-LED-E1-SL3-FINISH(Super Durable 038/90015 Pearl Dark Gray)-8030-600-HSS
 POLE: MCGRAW EDISON #RSS-4-M-20'(MOD TO 18')-S-FINISH(Super Durable 038/90015 Pearl Dark Gray)-DRILLING-2
 POWER SUPPLY: INTEGRAL ELECTRONIC SWITCHING POWER SUPPLY
 LIGHT SOURCE: INTEGRAL 3000K LEDS WITH 6000 NOMINAL LUMEN OUTPUT
 WATTS / VOLTAGE: 134W/120V

LS3 DESCRIPTION: SIMILAR TO TYPE LS1 EXCEPT WITH (1) TYPE III DISTRIBUTION AND (1) TYPE IV DISTRIBUTION HEADS ON A SINGLE POLE AT 180 DEGREES OPPOSING MOUNTING POSITION.

MANUFACTURER: MCGRAW EDISON #(1) GLEON-AF-02-LED-E1-SL3-FINISH(Super Durable 038/90015 Pearl Dark Gray)-8030-600-HSS / (1) GLEON-AF-02-LED-E1-SL4-FINISH(Super Durable 038/90015 Pearl Dark Gray)-8030-600-HSS
 POLE: MCGRAW EDISON #RSS-4-M-20'(MOD TO 18')-S-FINISH(Super Durable 038/90015 Pearl Dark Gray)-DRILLING-2
 POWER SUPPLY: INTEGRAL ELECTRONIC SWITCHING POWER SUPPLY
 LIGHT SOURCE: INTEGRAL 3000K LEDS WITH 6000 NOMINAL LUMEN OUTPUT
 WATTS / VOLTAGE: 134W/120V

SIEGEL & STRAIN Architects
 6201 Doyle Street Suite B
 Emeryville, CA 94608
 510 / 547-8092
 www.siegelstrain.com

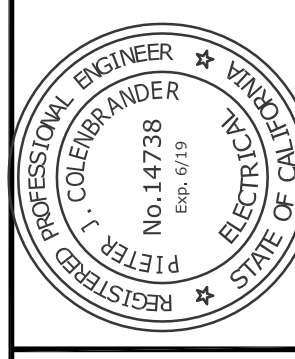

OAKLEY RECREATION CENTER
 OAKLEY
 CONTRA COSTA COUNTY
 CALIFORNIA

Date: 02/22/18	No.	Issue
Scale: AS NOTED	-	REBID SET
Design: DDP/JC	1	ADDENDUM 1
Drawn: TV		
Approved:		
Job No: 17-005		

Drawing Number:
E0.3

LUMINAIRE SCHEDULE

NUMBERED SHEET NOTES

- 10 WALL MOUNTED AT 8'-6" A.F.F. TO THE BOTTOM OF THE LUMINAIRE.
- 11 WALL MOUNTED AT 7'-9" A.F.F. TO THE BOTTOM OF THE LUMINAIRE. S.A.D.
- 12 PENDANT MOUNTED AT 7'-6" A.F.F. TO THE BOTTOM OF THE LUMINAIRE.
- 13 PENDANT MOUNTED AT 11'-6" A.F.F. TO THE BOTTOM OF THE LUMINAIRE.
- 14 RECESSED AT 18" A.F.F. TO THE CENTERLINE OF THE LUMINAIRE.
- 15 BOTH UP AND DOWNLIGHT POWER FEEDS ON INVERTER.
- 16 INDICATES DIMMING CONTROL CHANNEL IN COMMUNITY ROOM.
- 17 SEE SHEET E2.2 FOR LIGHTING IN THE MECHANICAL ATTIC.
- 18 ROOM CONTROLLER AND DIMMER FOR PLATFORM LIGHTS.
- 19 ROOM CONTROLLER FOR LOBBY LIGHTS.
- 20 (2) 6-BUTTON KEYPADS FOR (11) ZONE EXTERIOR OVERRIDE.

NUMBERED SHEET NOTES

- 1 REFER TO KITCHEN DRAWINGS FOR LIGHTING AND LIGHTING CONTROLS INTEGRATED WITH EXHAUST HOOD.
- 2 MASTER SCENE RECALL STATION.
- 3 REMOTE SCENE RECALL STATIONS: TYPICAL OF (4).
- 4 PROVIDE AN EMERGENCY LIGHTING CONTROL MODULE FOR ALL SWITCHED LIGHT FIXTURES ON EMERGENCY INVERTER. THIS INCLUDES EMERGENCY FIXTURES CONTROLLED BY OCCUPANCY SENSORS. SEE RELAY SCHEDULES AND DETAILS E5.3. MOUNT CONTROL MODULE/TEST SWITCH 7'-6" A.F.F. AND ALIGN WITH LIGHT SWITCH BELOW WHEREVER POSSIBLE.
- 5 BEAM MOUNTED ACCENT LIGHT.
- 6 PENDANT MOUNTED AT CONSISTENT DISTANCE FROM CURVED CEILING. SEE ARCHITECTURAL ELEVATIONS.
- 7 WALL MOUNTED AT 8'-6" A.F.F. TO THE BOTTOM OF THE LUMINAIRE.
- 8 CONCEALED LED COVE UPLIGHT.
- 9 PENDANT MOUNTED AT 7'-6" A.F.F. TO THE BOTTOM OF THE LUMINAIRE.

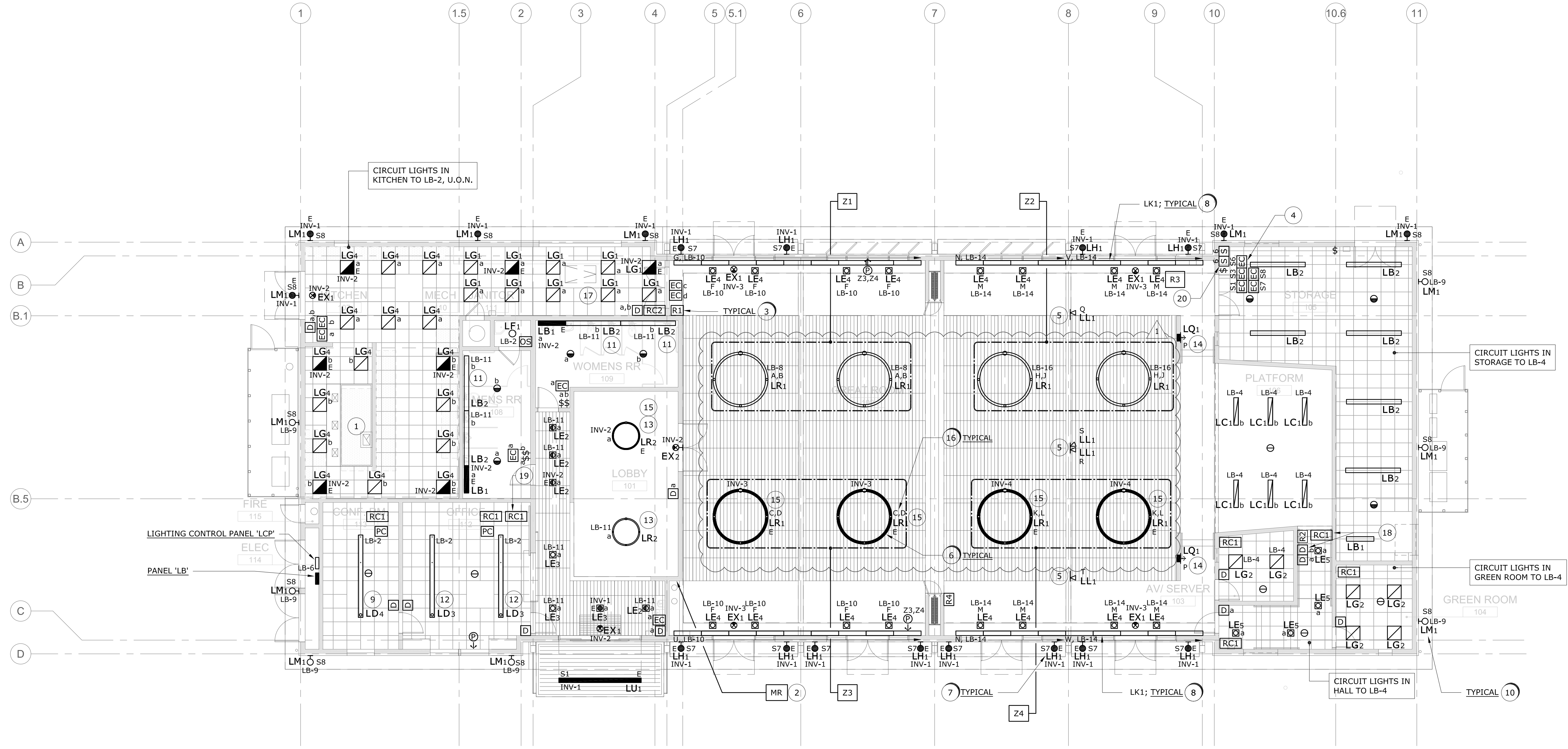

FLOOR PLAN - LIGHTING
SCALE: 1/8" = 1'-0"

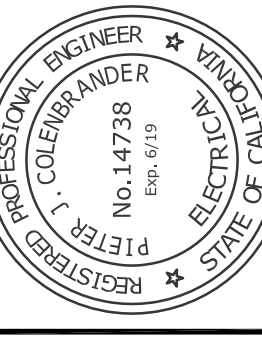
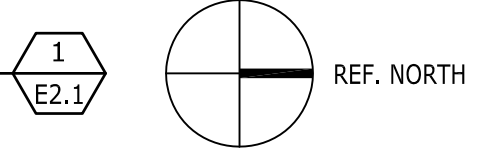

No.	1
Date	02/22/18
Scale	AS NOTED
Design	DOF/IC
Drawn	TV
Approved	
Sub No.	F-005

GENERAL SHEET NOTES

- SEE ARCHITECTURAL PLANS AND ELEVATIONS FOR EXACT DEVICE LOCATIONS.
- COORDINATE ROUGH-IN BOX REQUIREMENTS WITH ACTUAL AV EQUIPMENT PROVIDED FOR PROJECT.

SIEGEL & STRAIN Architects
 6201 Doyle Street Suite B
 Emeryville, CA 94608
 510 / 547-6092
 www.siegelstrain.com

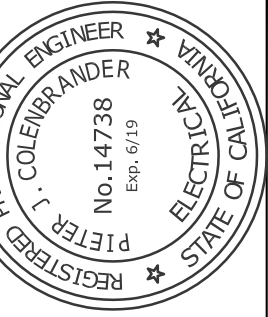

OAKLEY RECREATION CENTER
 CONTRA COSTA COUNTY CALIFORNIA
 OAKLEY

FLOOR PLAN - AV SYSTEM

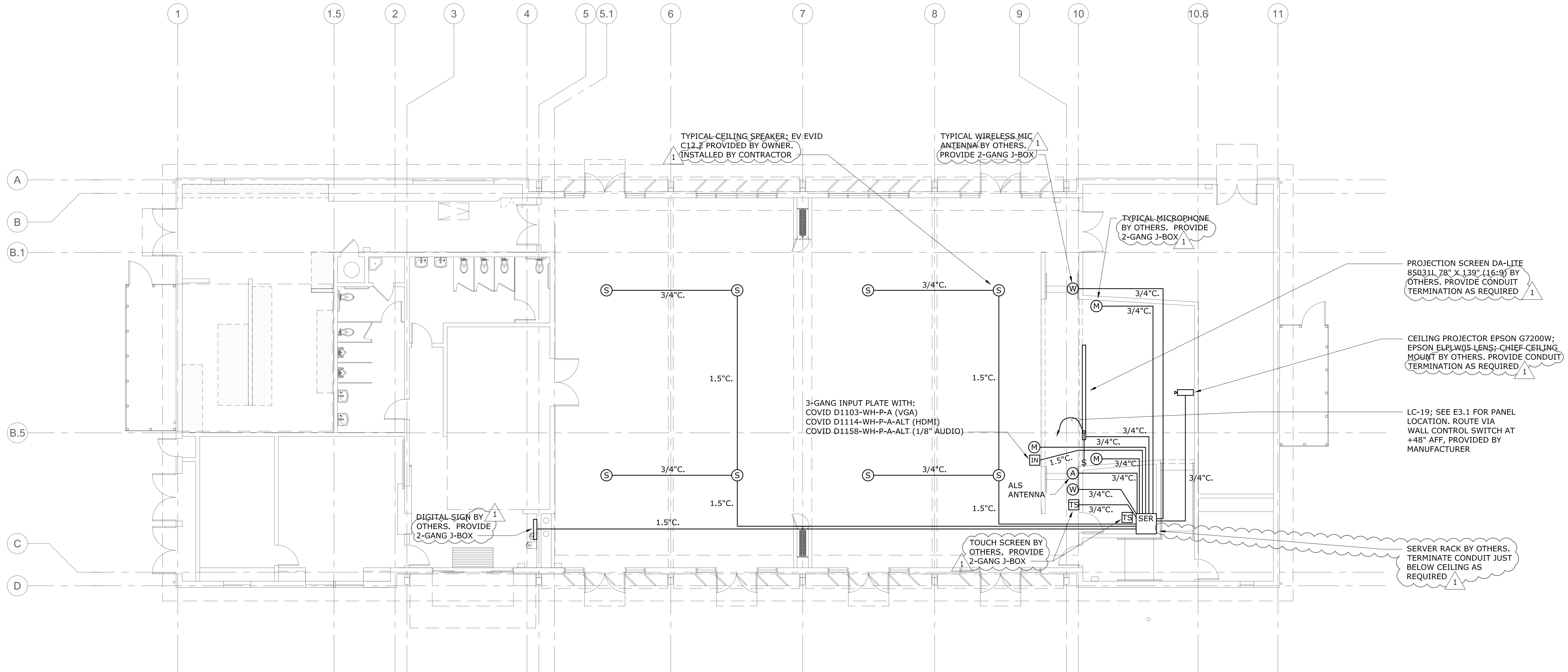

FLOOR PLAN - AV SYSTEM
 SCALE: 1/8" = 1'-0"

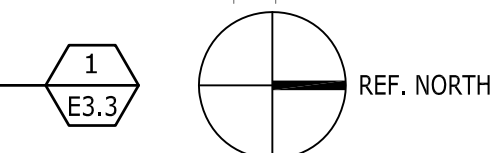

Date:	02/22/18	Issue	
Scale:	AS NOTED	REBID SET	02/14/18
Design:	DOF/JC	ADDENDUM 1	02/22/18
Drawn:	RS/TV		
Approved:			
Job No.:	17-005		

Drawing Number:
E3.3

INVERTER OUTPUT PANEL INV			
VOLTS:	120		
PHASE:	1		
BUSSING:	3 PH		
POLES:	6P		
LOAD DESCRIPTION	KVA	BRKR.	CKT
LTG - EXTERIOR	0.87	20/1	1
LTG - LOBBY, KITCHEN, MEN, WOMEN	0.4	20/1	2
LTG - GREAT ROOM	0.95	20/1	3
LTG - GREAT ROOM	0.95	20/1	4
SPARE		20/1	5
SPARE		20/1	6
PHASE A: 3170 VA			
26.42 MAX AMPS			

INVERTER UNIT SPECIFICATIONS INV

- ALL EMERGENCY SOURCE CIRCUITS SHALL BE INSTALLED IN SEPARATE RACEWAYS (FROM NORMAL POWER), PER 2014 NEC 700.10(B), OR APPLICABLE CODE AT THE TIME OF PERMITTING.
- REFER ALSO TO SPECIFICATIONS SECTION 265101. UNIT SHALL BE DUAL-LITE "SPECTRON LSN" OR APPROVED EQUAL NO. D124-375129-A2006-EML-IBS-S-FSL-PMPA3.
- UNIT SHALL BE 120V 1PH 2W INPUT, 120V OUTPUT, RATED 3.7KVA WITH 20AMP OUTPUT CIRCUIT BREAKERS.
- INPUT SHALL BE EQUIPPED WITH ANSI 62.41 SURGE PROTECTION AND 1HZ NOMINAL SYNCHRONIZING SLEW RATE.
- OUTPUT VOLTAGE STATIC REGULATION SHALL BE +/- 5% FOR 100% RESISTIVE LOAD.
- OUTPUT DISTORTION SHALL BE 5% THD MAXIMUM.
- OVERLOAD RATING: 150% MOMENTARY; 120% FOR 5 MINUTES.
- TRANSFER TIME: NO BREAK
- BATTERY SHALL BE SEALED LEAD CALCIUM, 10 YEAR LIFE, 90 MINUTE RUN TIME, WITH AUTO-DISCONNECT FOR LOW BATTERY VOLTAGE.
- PROVIDE RS232 PORT FOR EXTERNAL COMMUNICATIONS.
- INVERTER SHALL BE PWM TYPE.
- PROVIDE MAINTENANCE BAYS.
- PROVIDE IN NEMA 1 ENCLOSURE, FRONT ACCESS ONLY.
- PROVIDE FACTORY STARTUP AND TEST OF UNIT TO THE SATISFACTION OF BUILDING INSPECTION AUTHORITIES AND WITH MAXIMUM 4 HOURS OF PERSONNEL TRAINING FOLLOWING STARTUP.
- AUTO SELF TESTING.
- PROVIDE (6) OUTPUT CIRCUIT BREAKERS RATED 20AMPS EACH WITH DEDICATED CIRCUITS FOR EACH OF THE EMERGENCY LIGHTING LOADS. SEE INVERTER LOAD SCHEDULE, SHEET E6.1.
- SEISMIC QUALIFIED.
- SUBMIT FOR REVIEW AND APPROVAL.

PANEL LB											
VOLTS:	120 / 208										
PHASE:	3 PH										
WIRE:	4 W										
BUSSING:	100A										
POLES:	42P										
LOAD DESCRIPTION	TYPE	A	B	C	BRKR.	CKT.	CKT.	BRKR.	A	B	C
LTG - SITE BOLLARD	L	0.53			20/1	1	2	20/1	0.97		
LTG - SITE BOLLARD	L		0.60		20/1	3	4	20/1		1.01	
LTG - PARKING POLE LTS	L			1.45	20/1	5	6	20/1			0.20
LTG - PARKING POLE LTS	L	1.29			20/1	7	8	20/1	1.46		
LTG - EXTERIOR BUILDING	L		1.02		20/1	9	10	20/1		0.57	
LTG - ATTIC, LOBBY, WOMEN, MEN	L			0.95	20/1	11	12	20/1			
SPARE					20/1	13	14	20/1	0.82		
SPARE					20/1	15	16	20/1		1.46	
SPARE					20/1	17	18	20/1			
SPARE					20/1	19	20	20/1			
SPARE					20/1	21	22	20/1			
SPARE					20/1	23	24	20/1		3.18	
SPARE					25	26					
SPARE					27	28					
SPARE					29	30					
SPARE					31	32					
SPARE					33	34					
SPARE					35	36					
SPARE					37	38					
SPARE					39	40					
SPARE					41	42					
TOTALS: 1.82 1.62 2.40 3.05 3.04 3.38											
DEMAND LOAD SUMMARY											
TYPE "M": NON-CONTINUOUS / MISC. LOADS	0.00	100%	0.00								
TYPE "L": LIGHTING / CONTINUOUS LOADS	15.31	125%	19.14								
TYPE "R": RECEPTACLES (FIRST 10KVA)	0.00	100%	0.00								
TYPE "R": RECEPTACLES (OVER 10KVA)	0.00	50%	0.00								
TYPE "H": HVAC / MECHANICAL LOADS	0.00	100%	0.00								
TOTALS:	15.31		19.14								
PHASE A: 4.87 KVA											
PHASE B: 4.68 KVA											
PHASE C: 5.78 KVA											
48.17 MAX AMPS / PHASE											

PANEL 'LCP'															
Load Schedule w/ Panel Terminations															
Project: Oakley Rec Center						Panel ID: LCP									
Creator: RHDD						Feed Feed Through									
Date: 2/21/2018						Revision: 02									
Cabinet Voltage: 120V															
Area	Room #	Zone Name	Zone #	Circuit #	Voltage	Module Type	Module #	Output #	Fixture Type	Load Type	Dis. (Y/N)	Fixture Watts	Qty	Total Watts	Mod. Watt
EXTERIOR		LINEAR DOWNLIGHTS AT ENTRY	S1		120	DRH40BFLV4	1	1	SWITCHED	N				5	
EXTERIOR		BOLLARDS	S2		120		1	2	SWITCHED	N				498	
EXTERIOR		BOLLARDS	S3A		120		1	3	SWITCHED	N				301	
EXTERIOR		BOLLARDS	S3B		120		1	4	SWITCHED	N				262	
EXTERIOR		POLE LIGHTS	S5A		120		1	5	SWITCHED	N				420	
					120		1	6	SWITCHED	N					
					120		1	7	SWITCHED	N					
					120		1	8	SWITCHED	N					
EXTERIOR		POLE LIGHTS	S5B		120	DRH40BFLV4	2	1	SWITCHED	N				420	
EXTERIOR		POLE LIGHTS	S5C		120		2	2	SWITCHED	N				430	
EXTERIOR		SITE LIGHTS	S6		120		2	3	SWITCHED	N				5	
EXTERIOR		SCISSORS AT DOORS	S7		120		2	4	SWITCHED	N				5	
EXTERIOR		BUILDING WALL MOUNTED	S8		120		2	5	SWITCHED	N				203	
EXTERIOR		SPRINKLER LIGHTING AT ROOF	S9		120		2	6	SWITCHED	N				240	
					120		2	7	SWITCHED	N					
					120		2	8	SWITCHED	N					
EXTERIOR		POLE LIGHTS	S4A		120	DRH40BFLV4	2	1	SWITCHED	N				483	
EXTERIOR		POLE LIGHTS	S4B		120		2	2	SWITCHED	N				483	
EXTERIOR		POLE LIGHTS	S4C		120		2	3	SWITCHED	N				483	
					120		2	4							
EXTERIOR		MONUMENT BRN	S11		120		2	5	SWITCHED	N				190	
					120		2	6	SWITCHED	N					
					120		2	7	SWITCHED	N					
					120		2	8	SWITCHED	N					
COMMUNITY ROOM	102	RING PENDANT UPLIGHT - SOUTH	A		120	DRH40BFLV4	3	1	LRI	0-10V	Y	190	2	380	
COMMUNITY ROOM	102	RING PENDANT DOWNLIGHT - SOUTH	B		120		3	2	LRI	0-10V	Y	285	2	570	
COMMUNITY ROOM	102	EM RING PENDANT UPLIGHT - SOUTH	C		120		3	3	LRI	0-10V	Y	190	2	380	
COMMUNITY ROOM	102	EM RING PENDANT DOWNLIGHT - SOUTH	D		120		4	1	LRI	0-10V	Y	285	2	570	
COMMUNITY ROOM	102	RING PENDANT UPLIGHT - NORTH	E		120	DRH40BFLV4	4	1	LRI	0-10V	Y	190	2	380	
COMMUNITY ROOM	102	RING PENDANT UPLIGHT - NORTH	H		120		4	2	LRI	0-10V	Y	190	2	380	
COMMUNITY ROOM	102	RING PENDANT DOWNLIGHT - NORTH	J		120		4	3	LRI	0-10V	Y	285	2	570	
COMMUNITY ROOM	102	EM RING PENDANT UPLIGHT - NORTH	K		120		4	4	LRI	0-10V	Y	190	2	380	
COMMUNITY ROOM	102	EM RING PENDANT DOWNLIGHT - NORTH	L		120	DRH40BFLV4	5	1	LRI	0-10V	Y	285	2	570	
COMMUNITY ROOM	102	PROBE TEST DOWNLIGHT - NORTH	M		120		5	2	LRI	0-10V	Y	11	8	130	
COMMUNITY ROOM	102	STEPS/LIGHTS - NORTH	P		120		5	3	LRI	0-10V	Y	2	2	4	
COMMUNITY ROOM	102	COVE UPLIGHTS - SOUTHWEST	G		120		5	4	LRI	0-10V	Y	345	1	345	
COMMUNITY ROOM	102	FLL LIGHT - NORTHWEST	O		120	DRH40BFLV4	6	1	LL1	0-10V	Y	18	1	18	
COMMUNITY ROOM	102	KEY LIGHT - NORTHWEST	R		120		6	2	LL1	0-10V	Y	18	1	18	
COMMUNITY ROOM	102	KEY LIGHT - NORTHEAST	S		120		6	3	LL1	0-10V	Y	18	1	18	
COMMUNITY ROOM	102	FLL LIGHT - NORTHEAST	T		120		6	4	LL1	0-10V	Y	18	1	18	
COMMUNITY ROOM	102	COVE UPLIGHTS - SOUTHEAST	U		120		7	1	LRI	0-10V	Y	345	1	345	
COMMUNITY ROOM	102	COVE UPLIGHTS - NORTHEAST	N		120	DRH40BFLV4	7	2	LRI	0-10V	Y	152	2	304	
COMMUNITY ROOM	102	COVE UPLIGHTS - NORTHWEST	V		120		7	3	LRI	0-10V	Y	190	1	190	
COMMUNITY ROOM	102	COVE UPLIGHTS - NORTHEAST	W		120		7	4	LRI	0-10V	Y	190	1	190	

PANEL LA											
VOLTS:	120 / 208										
PHASE:	3 PH										
WIRE:	4 W										
BUSSING:	225A										
POLES:	54P										
LOAD DESCRIPTION	TYPE	A	B	C	BRKR.	CKT.	CKT.	BRKR.	A	B	C
EXT. AT 115: FIRE SPRINKLER ALARM BELL	M	0.10			20/1	1	2	20/1			
110: GAS WTR/HTGR, GWH, 182IRC PUMP CP-1	H		0.20		20/1	3	4	20/1		0.90	
FANS: F3@108; F4@109; F5@111A; F8@112	H			0.33	20/1	5	6	20/1			0.36
SPARE					20/1	7	8	20/1	0.36		
101: ELEC. SLIDING DOOR 101A	M		1.20		20/1	9	10	20/1		0.36	
101: FAN F6 (1.5HP)	H	1.14			20/2	11	12	20/1			0.54
	H		1.14		20/2	13	14	20/1	0.90		
	H	0.06			15/2	15	16	20/1		0.54	
	H		0.06		15/2	17	18	20/1			0.36
101: FC-1B-1	H	0.93			15/2	19	20	20/1	1.20		
	H		0.93		21	22	20/1		0.72		
109: FC-1B-2	H	0.93			15/2	23	24	20/1		0.90	
	H		0.93		25	26	20/1	0.90			
112: FC-2-1	H		0.93		15/2	27	28	20/1		0.90	
	H			0.93	29	30	20/1			0.30	
113: FC-2-2	H	0.03			15/2	31	32	20/1	0.54		
	H		0.03		33	34	20/1				
112: FC-2-3	H		0.03		15/2	35	36	20/1			
	H	0.03			37	38	20/1				
107: FC-2-4	H		0.12		15/2	39	40	20/1			
</											