



STANDARD PLANS

Prepared By:

The City of Oakley
Public Works and Engineering Department

JUNE 2016

OAKLEY

CALIFORNIA

*3231 Main Street
Oakley, CA 94561*

INTRODUCTION

The City of Oakley presents the first volume of Standard Plans developed by the Public Works and Engineering Department. The City of Oakley has adopted the Caltrans Standard Plans, but the City of Oakley Standard Plans are specific to the City's public improvements. The City Standard Plans will govern between conflicting details with Caltrans and Contra Costa County standard details.

These drawings shall be used in conjunction with the latest edition of the Caltrans Standard Specifications, Standard Specifications for Public Works Construction (i.e. "The GREENBOOK"), and project specific City of Oakley Specifications.

All details pertaining to the design of potable water, recycled water and sanitary sewer systems shall be reviewed and approved by Diablo Water District and Ironhouse Sanitary District respectively.

All curb ramps and accessible routes shall conform to Caltrans Standards, Americans with Disabilities Act Accessibility Guidelines (ADAAG), and Title 24 of the California Building Code.

These drawings are not to scale; therefore, they must be used with care and judgment.

A hard copy of the City of Oakley Standard Plans is available for purchase at the City of Oakley Permit Center located at 3231 Main Street, Oakley, CA 94561.

COMMENTS

The City of Oakley is committed to the quality of this publication and desires to correct any errors, omissions or ambiguities in the next publication of this document. If you have any comments, corrections, or additions you would like to submit for consideration to be included in the next publication, you are encouraged to submit them to:

City of Oakley
Public Works and Engineering Department
3231 Main Street
Oakley, CA 94561

(925) 625-7037

publicworks@ci.oakley.ca.us

TABLE OF CONTENTS

DESCRIPTION	PAGE #
STREETS	
Typical Sections – Major Roads.....	X-01
Typical Sections – Residential.....	X-02
Street End Layout Options.....	X-03
Driveway and Intersection Sight Triangles.....	X-04
Concrete Curb & Gutter.....	C-01
Concrete Vertical Curb.....	C-02
Concrete Divider/ Mowing Band.....	C-03
Concrete Sidewalk - Monolithic & Separated	C-04
Concrete Driveway with Planter	C-05
Concrete Driveway without Planter.....	C-06
Concrete Driveway to Sidewalk Reconstruction.....	C-07
HMA Conform Details.....	C-08
Speed Hump	C-09
STORM DRAIN	
Curb Drain.....	SD-01
Concrete Valley Gutter.....	SD-02
Pipe Trench Detail.....	SD-03
Pipe Trench Notes.....	SD-04
Manhole/Catch Basin & Valve Box Adjustment.....	SD-05
Standard Manhole.....	SD-06
Manhole Frame and Cover.....	SD-07
Type I Curb Inlet.....	SD-08
Type II Inlet.....	SD-09
Type III Landscape Area/Park Inlet.....	SD-10
Reticuline Frame & Grate.....	SD-11
Storm Drain Marker.....	SD-12
ELECTRICAL	
Street Light – Cobra Head Double LED.....	E-01
Street Light – Cobra Head Single LED.....	E-02
Street Light – Decorative Double LED.....	E-03
Street Light – Decorative Single LED.....	E-04
Signal Specifications and Equipment List.....	E-05

TABLE OF CONTENTS (continued)

DESCRIPTION	PAGE #
 SIGNS	
Street Name Sign – Major Street.....	SS-01
Street Name Sign – Minor Street.....	SS-02
Street Name Sign – Location and Mounting.....	SS-03
 LANDSCAPE	
Preferred Tree List.....	L-01
Tree Planting Specifications.....	L-02
Tree Planting	L-03
Shrub Planting	L-04
 IRRIGATION	
Irrigation Equipment List.....	IR-01
Irrigation System Thrust Blocking.....	IR-02
Irrigation Controller.....	IR-03
Irrigation Controller Enclosure Top Opening.....	IR-04
Master Valve and Flow Sensor.....	IR-05
Flow Sensor Detail.....	IR-06
CCU or Field Satellite Grounding Grid.....	IR-07
Irrigation Valve Box Installation.....	IR-08
Irrigation Wire Connection.....	IR-09
Remote Control Valve.....	IR-10
Quick Coupling Valve.....	IR-11
Gate/Ball Valve.....	IR-12
Rotor and Pop-Up Spray Head.....	IR-13
Shrub Bubbler and Flexible Riser	IR-14
Irrigation Electric Meter Pedestal.....	IR-15
 MISCELLANEOUS	
Park Furnishings	M-01
Removable Bollard Park or Trail	M-02
Fence – Chain Link.....	M-03
Solid Waste Trash Enclosure.....	M-04

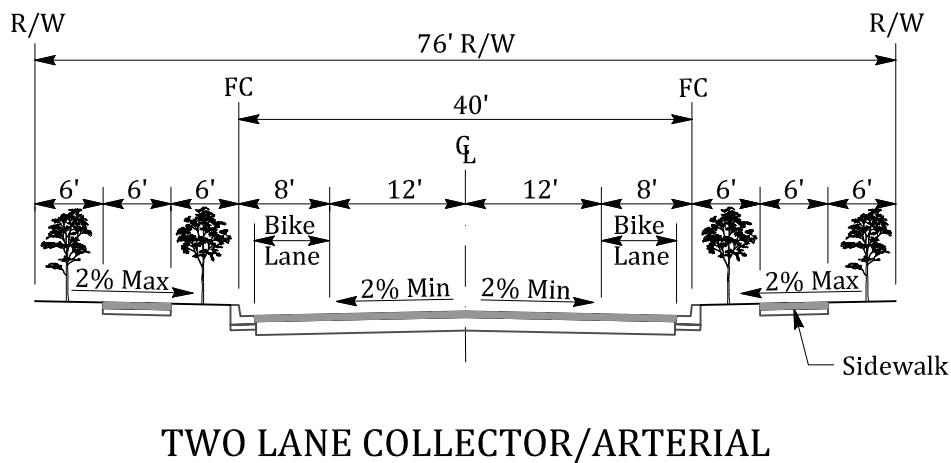
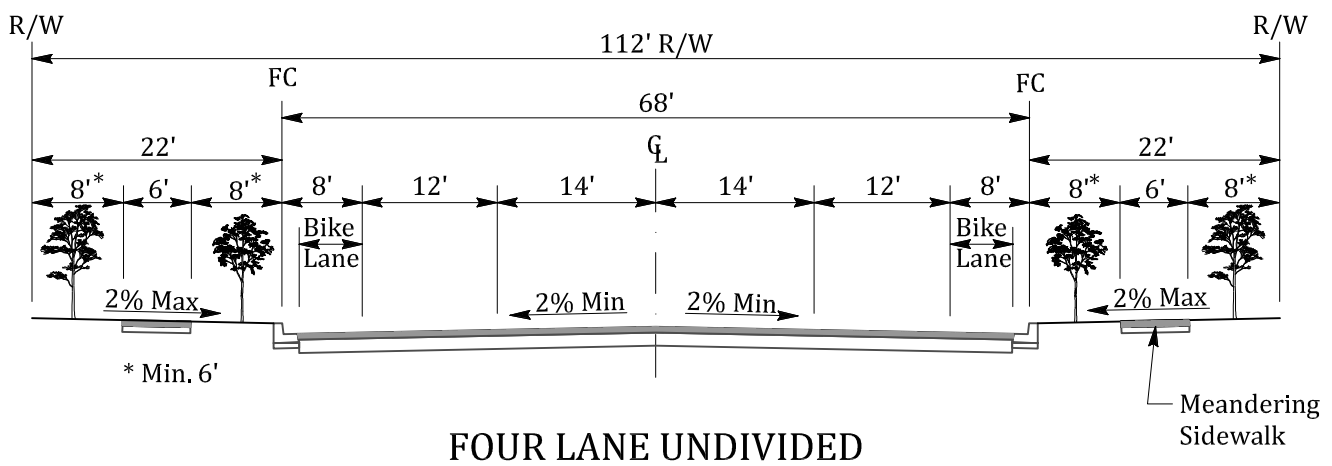
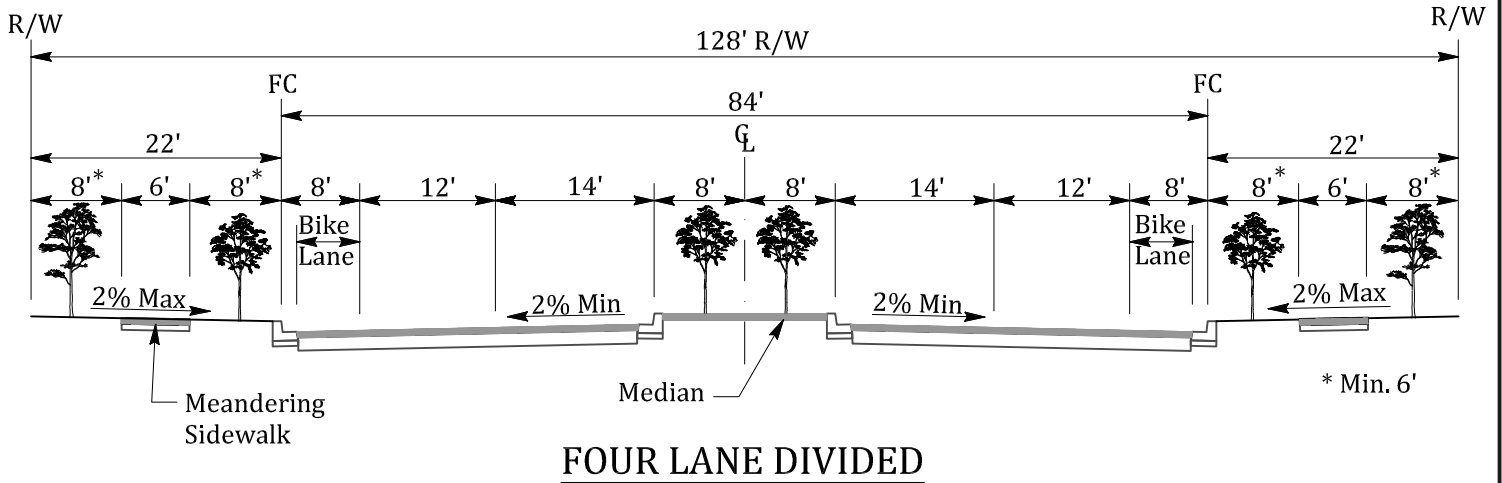

FC = Face of Curb

NOT TO SCALE

APPROVED BY	DATE		TYPICAL SECTIONS MAJOR ROADS	STD. PLAN NO.
 CITY ENGINEER	JUNE 2016			X-01

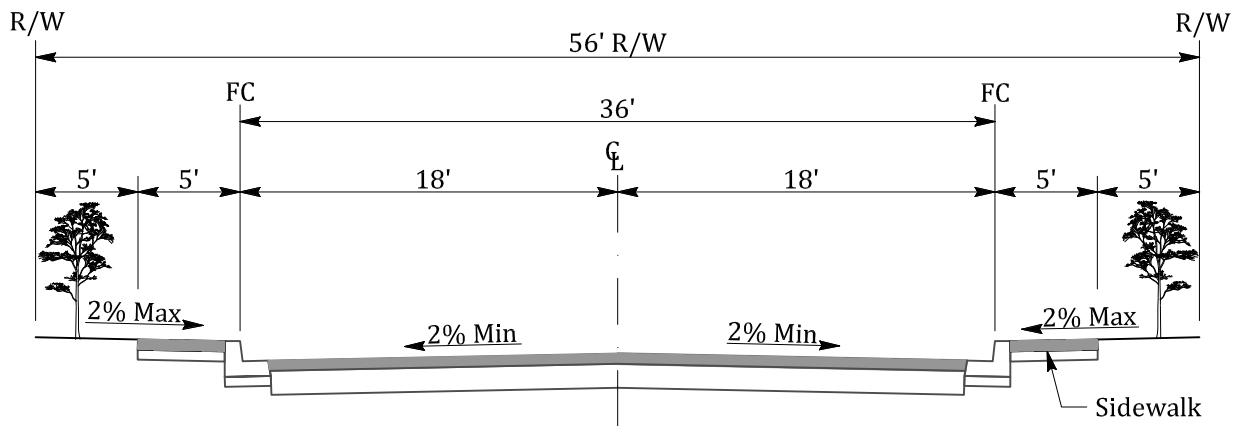

MINOR/RESIDENTIAL STREET

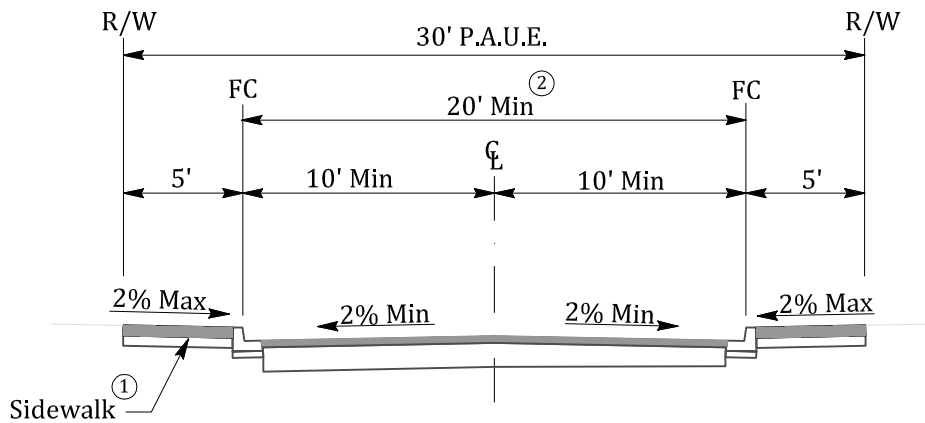

PRIVATE ACCESS ROAD

NOTES:

1. Sidewalk per the approval of the Planning Division.
2. Street widths subject to the approval of the Fire District and Planning Division.

FC=Face of curb

NOT TO SCALE

APPROVED BY	DATE		TYPICAL SECTIONS RESIDENTIAL	STD. PLAN NO.
	JUNE 2016			X-02
CITY ENGINEER				

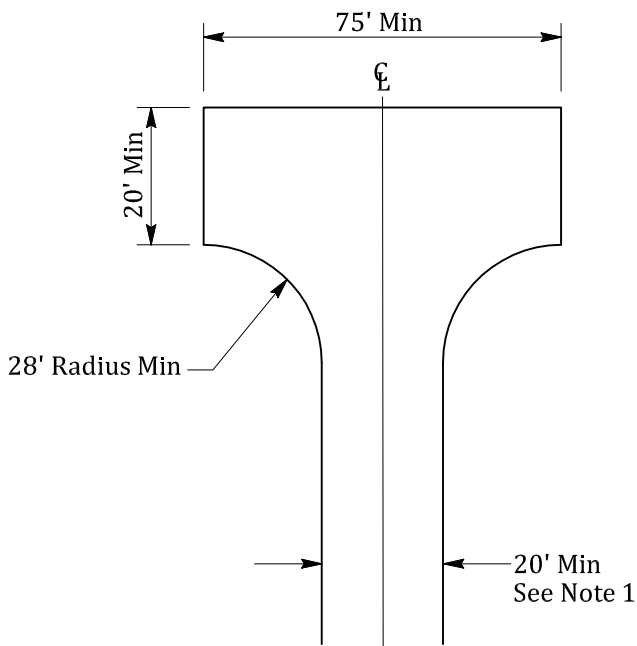

HAMMERHEAD
(Private Only)

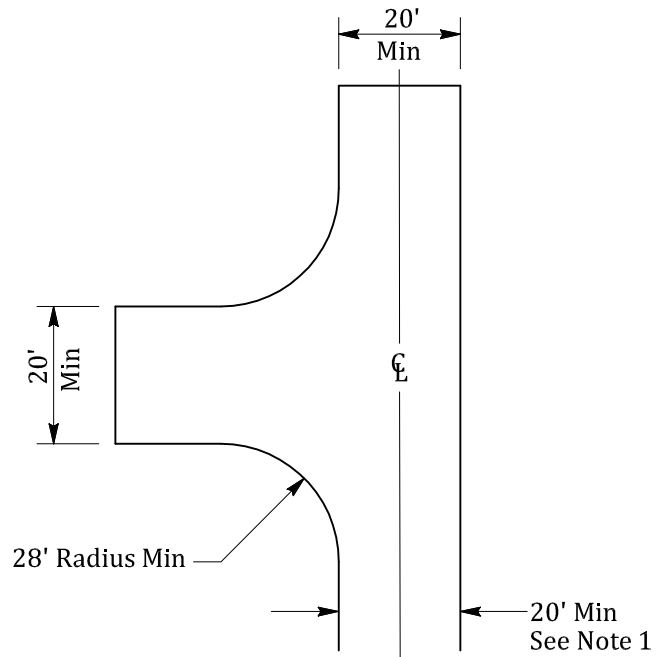

SHUNT
(Private Only)

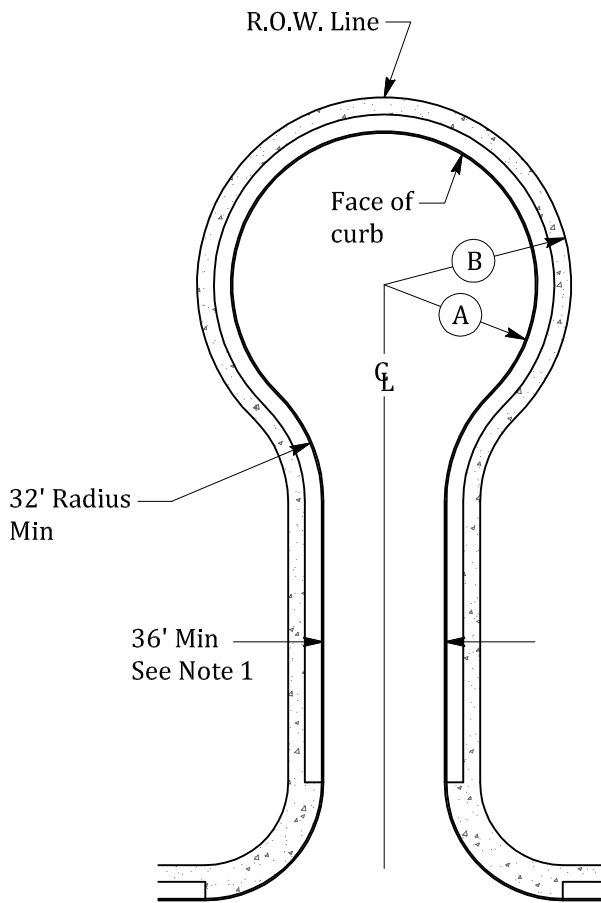

CUL-DE-SAC

ROAD TYPE	RADIUS	
	(A)	(B)
Residential Street	45'	55'
Commercial/ Industrial Street	55'	65'

NOTES:

1. Minimum Roadway widths:
20 Feet - no parking
32 Feet - parking on one side
36 Feet - parking on both sides
2. Cross slope within turnaround shall not exceed 8% grade.
3. Surface shall be all-weather and capable of supporting a 37 ton vehicle.
4. Cul-de-Sac shall have standard curb and gutter, See Std Plan C-01.
5. Standards are minimum City requirements subject to Fire District approval.

NOT TO SCALE

APPROVED BY	DATE		STREET END LAYOUT OPTIONS	STD. PLAN NO.
 CITY ENGINEER	JUNE 2016			X-03

NOTES:

1. Foliage at maturity and berm, if any, shall not exceed 3 feet in height.
2. A visual clearance from the street to 15 feet in height shall be maintained with all tree foliage within the sight triangle.
3. A visual clearance from the sidewalk to 7 feet in height shall be maintained with all tree foliage within the sight triangle.
4. Site specific sight triangle exhibit to be provided upon request by the Public Works and Engineering Department

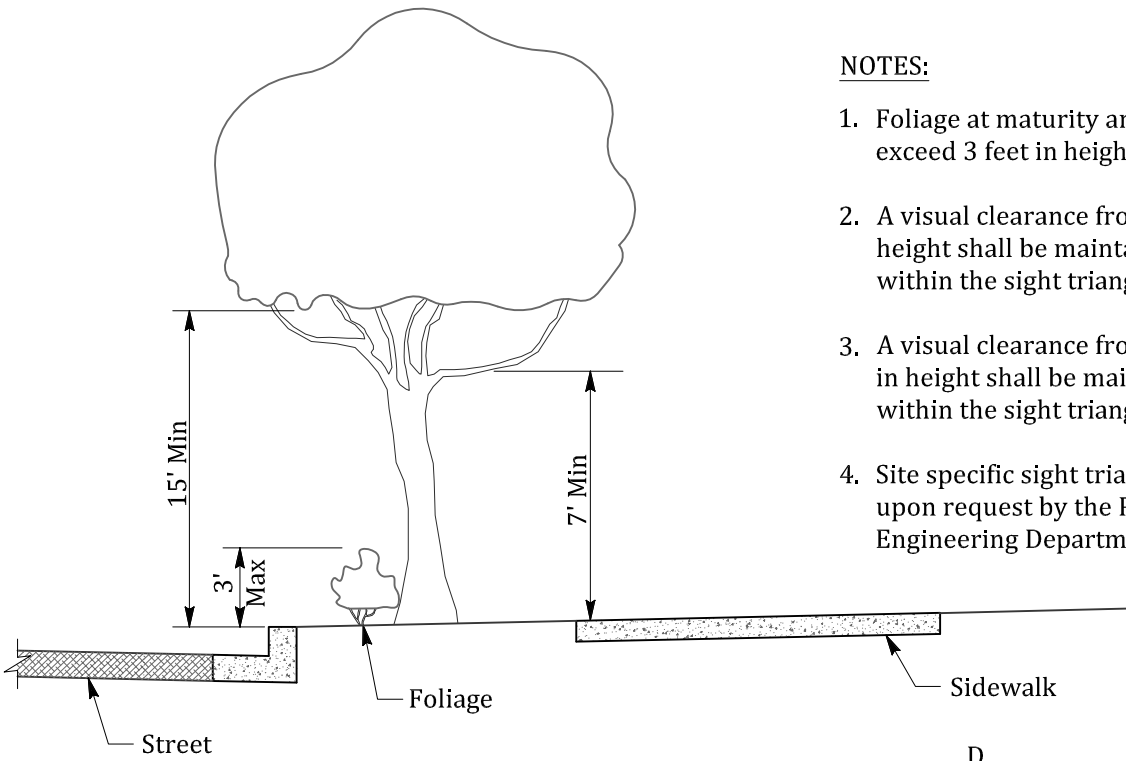

MAJOR ROAD POSTED SPEED LIMIT (MPH)	D MINIMUM DISTANCE (FT)*
25	280
30	335
35	390
40	445
45	500

* AASHTO GREEN BOOK

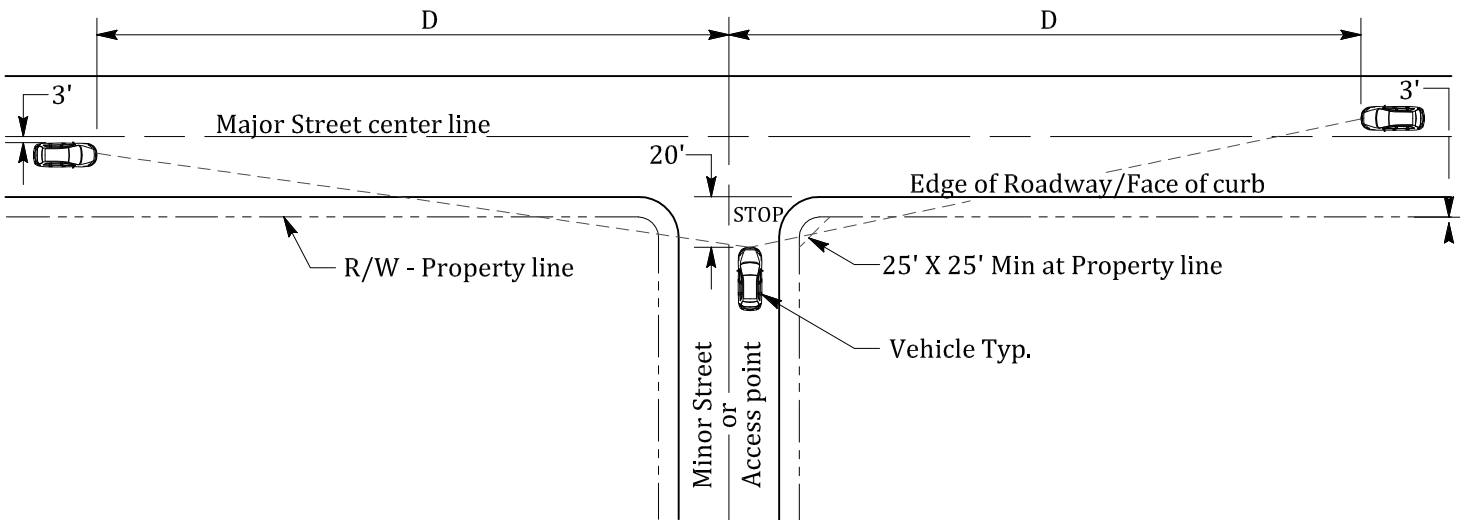

MAJOR STREET WITH STOP CONTROL ON MINOR STREET

NOT TO SCALE

APPROVED BY	DATE		DRIVEWAY AND INTERSECTION SIGHT TRIANGLES	STD. PLAN NO.
	JUNE 2016			X-04
CITY ENGINEER				

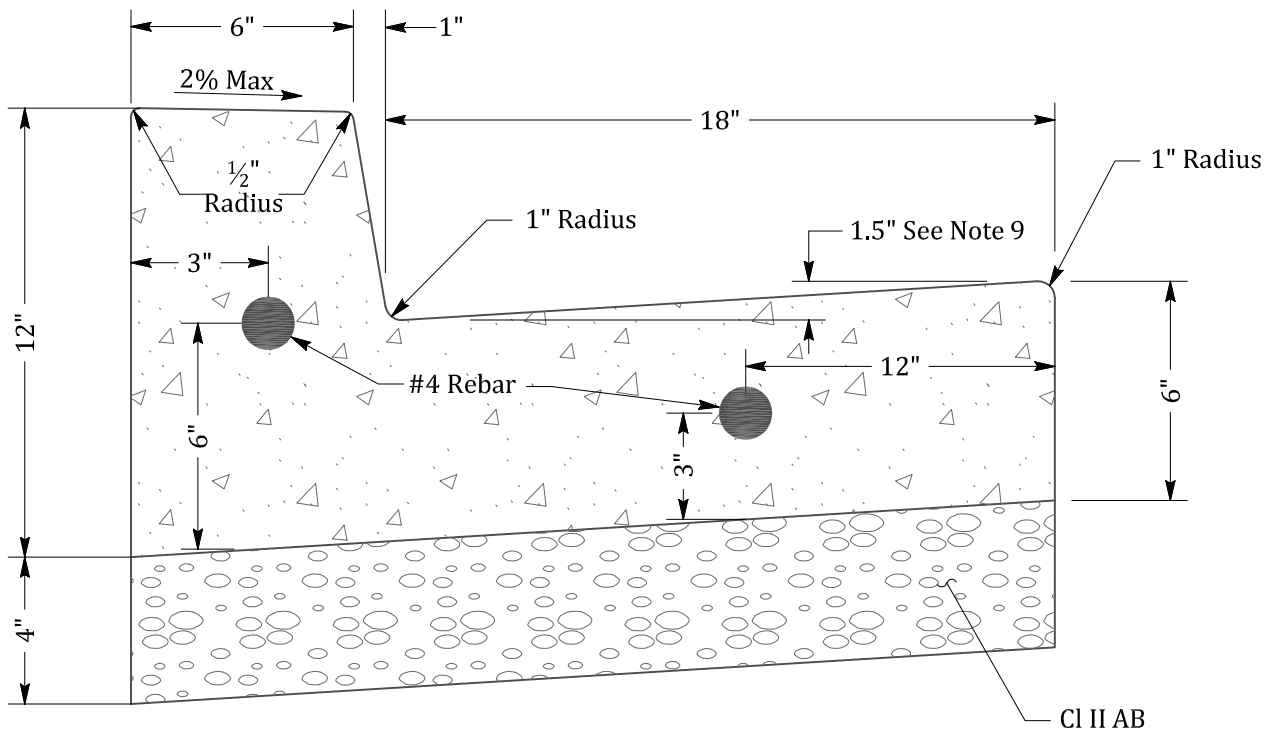

NOTES:

1. All radii less than 100' shall use flexible wood or metal forms to eliminate angular points at 10' section points.
2. Sawcut and remove 18 inch minimum street section for curb and gutter installation on existing streets.
3. 3/4" expansion joints to be placed at driveway sections, curb returns curb ramps & cold joints or a maximum of 30' center to center. Expansion joints shall protrude 1" below the bottom of gutter.
4. Thru joints shall be placed adjacent to catch basins, inlets at points of tangency on streets, and at alley and driveway returns. Maximum spacing shall be 30' pre-molded joint filler, shall be 1/2" wide and conform to AASHTO design M213. Dummy joints shall be placed every 10'.
5. Finished work shall not vary more than 1/8" in grade and 1/4" in alignment.
6. The finished curb shall immediately be sprayed with a transparent curing compound. Curb shall be covered by waterproof paper or plastic membrane in the event of rain or other unsuitable weather. Curing time shall be a minimum of 72 hours.
7. All curb and gutter shall be placed on a minimum of 4" Aggregate Base Class II 95% maximum compaction ASTM D1557.
8. #4 Rebar shall be extended along full length of the curb and gutter.
9. Gutter pan slope shall not exceed 5% at pedestrian curb ramp entry locations. Contractor shall use 1.2" maximum between lip of gutter flow line at these locations.
10. All concrete shall be per current Caltrans Specifications Section 73 "Concrete Curbs and Sidewalks" and Section 90 "Concrete". Concrete shall include two (2) pounds of liquid lamp black per cubic yard of concrete. Liquid lamp black color shall be "Davis A 8090 Black" or equal.
11. All curb and gutter shall have 2-#4 Rebar the entire length and embedded on both end using dowels (one dowel in the center of the gutter, one dowel in the center of the curb).

NOT TO SCALE

APPROVED BY	DATE		CONCRETE CURB AND GUTTER	STD. PLAN NO.
 CITY ENGINEER	APRIL 2017 Rev. 4/19/17			C-01

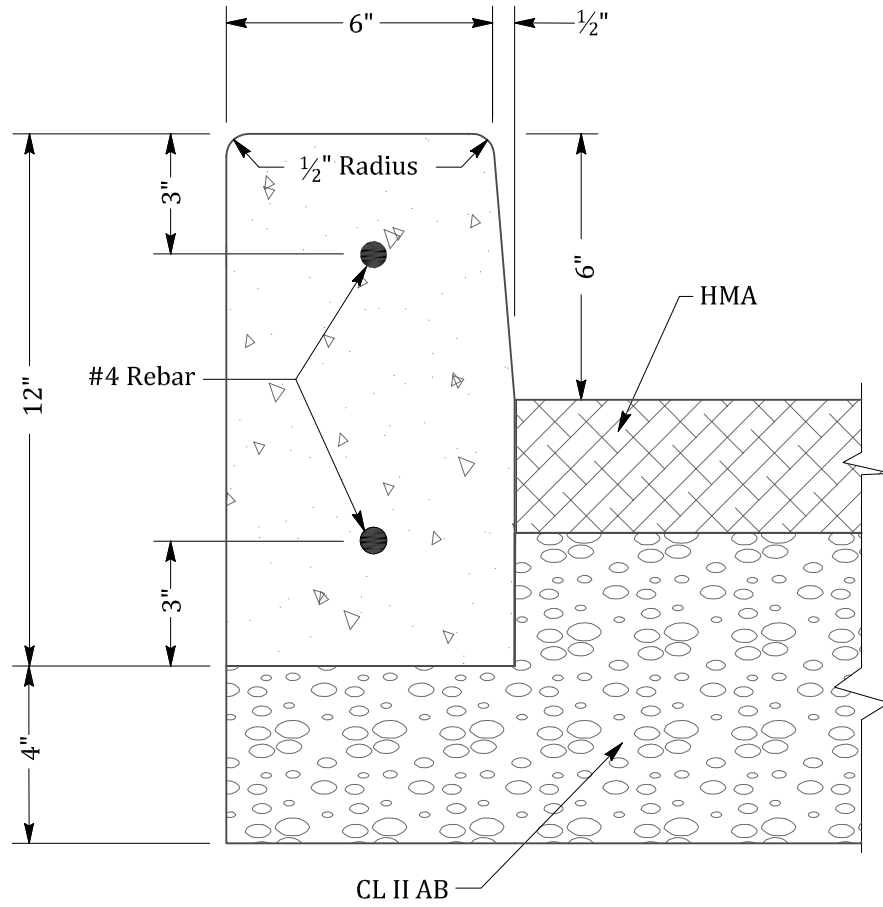

NOTES:

1. The construction notes of Standard Plan C-01 apply to concrete vertical curb.
2. Median islands shall have 8" vertical clearance from Top of Curb to Pavement.

NOT TO SCALE

APPROVED BY	DATE		CONCRETE VERTICAL CURB	STD. PLAN NO.
 CITY ENGINEER	JUNE 2016			C-02

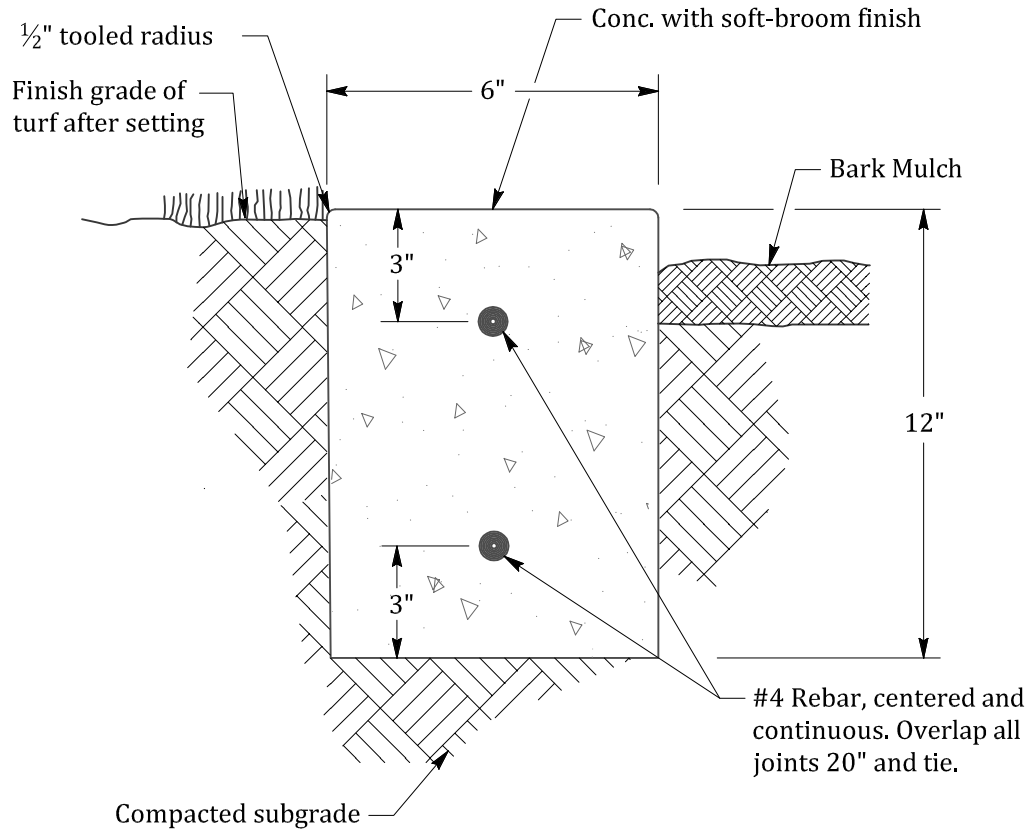

SECTION

NOTES:

1. Provide $\frac{1}{4}$ " wide by $\frac{1}{2}$ " deep score lines at 8'-0" O.C. and expansion joints at 32'-0" O.C.

NOT TO SCALE

APPROVED BY	DATE		CONCRETE DIVIDER/MOWBAND	STD. PLAN NO.
<i>Kevin Rohani</i>	JUNE 2016			C-03
CITY ENGINEER				

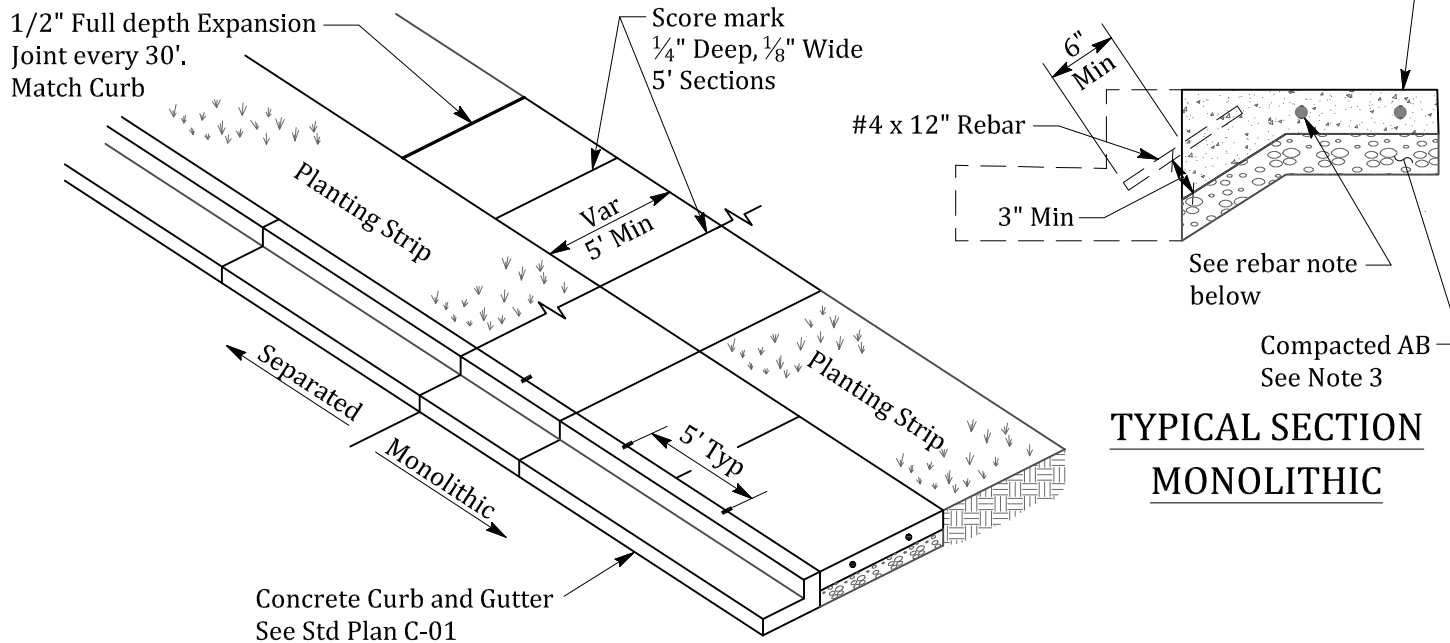

**TYPICAL SECTION
MONOLITHIC**

PLAN VIEW

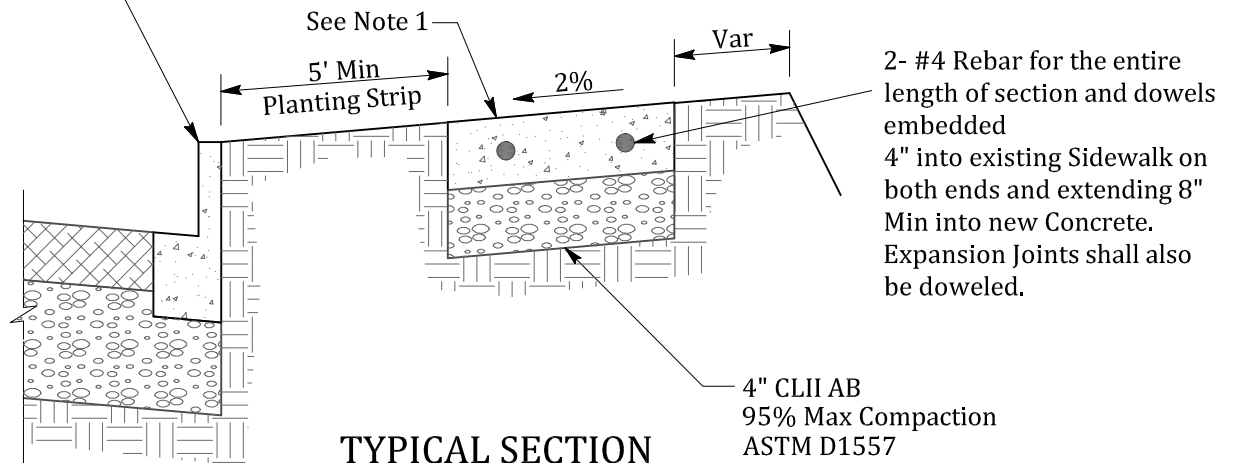

**TYPICAL SECTION
SEPARATED**

NOTES:

1. Sidewalk shall be a minimum of 4". All concrete shall be per current Caltrans Specifications Section 73 "Concrete Curbs and Sidewalks" and Section 90 "Concrete". Concrete shall include two (2) pounds of liquid lamp black per cubic yard of concrete. Liquid lamp black color shall be "Davis A 8090 Black" or equal.
2. Full Expansion Joints shall be placed to match those placed in adjacent Curb & Gutter, with maximum spacing of 30 feet.
3. Subgrade shall have 95% maximum compaction ASTM D1557.
4. Sidewalk shall be at least 6" thick behind Rolled Curb and Residential Driveways and 8" thick behind Commercial Driveways.
5. The finished Sidewalk shall be sprayed with a transparent Curing Compound covered by Waterproof Paper or Plastic Sheeting in the event of rain or other inclement weather; curing time shall be for a minimum of 72 hours.
7. All joints shall be cleaned and edged with an edger having a 1/4" radius.
8. Sidewalk and Planter Strip widths shall conform to dimensions shown in appropriate street cross section details.
9. The width of Sidewalk directly behind Curb without Planter shall be a minimum of 5' from back of curb.
10. Exposed surfaces shall be a light broom finish.

NOT TO SCALE

APPROVED BY	DATE		CONCRETE SIDEWALK MONOLITHIC AND SEPARATED	STD. PLAN NO.
	APRIL 2017			C-04
CITY ENGINEER	Rev. 9/28/17			

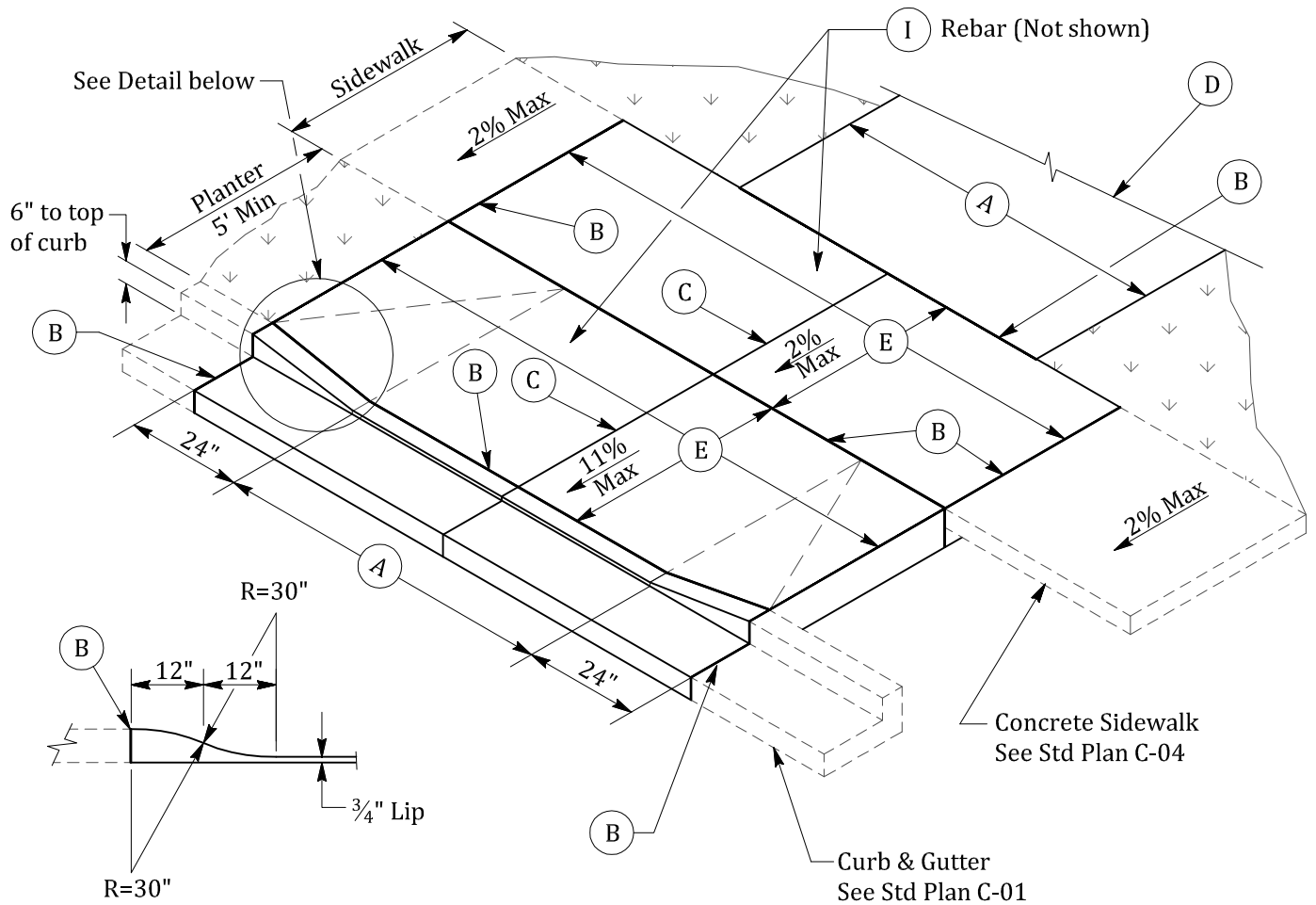

CURB TRANSITION DETAIL

NOTES

- (A) Equals width of Driveway at property line, 14' Min - 30' Max for Residential & 25' Min - 35' Max for Commercial.
- (B) 1/2" wide full depth Expansion Joint.
- (C) Full depth Expansion Joint if (A) is 15' or greater.
- (D) Driveway to be surfaced with asphalt or concrete.
- (E) Driveway concrete shall be a Minimum of 6" thick for Residential & 8" thick for Commercial locations and is to be placed on a minimum of 4" Class II Aggregate Base 95% maximum compaction, ASTM D1557. Over 95% compacted subgrade.
- (F) All concrete shall be per current Caltrans Specifications Section 73 "Concrete Curbs and Sidewalks" and Section 90 "Concrete". Concrete shall include two (2) pounds of liquid lamp black per cubic yard of concrete. Liquid lamp black color shall be "Davis A 8090 Black" or equal.
- (G) Sawcut and remove 18" minimum street section for driveway installation in existing streets.
- (H) All work shall conform to current ADA requirements.
- (I) #4 Rebar 16" O.C. both ways minimum 3" cover.

NOT TO SCALE

APPROVED BY	DATE		CONCRETE DRIVEWAY WITH PLANTER	STD. PLAN NO.
 CITY ENGINEER	APRIL 2017 Rev. 4/19/17			C-05

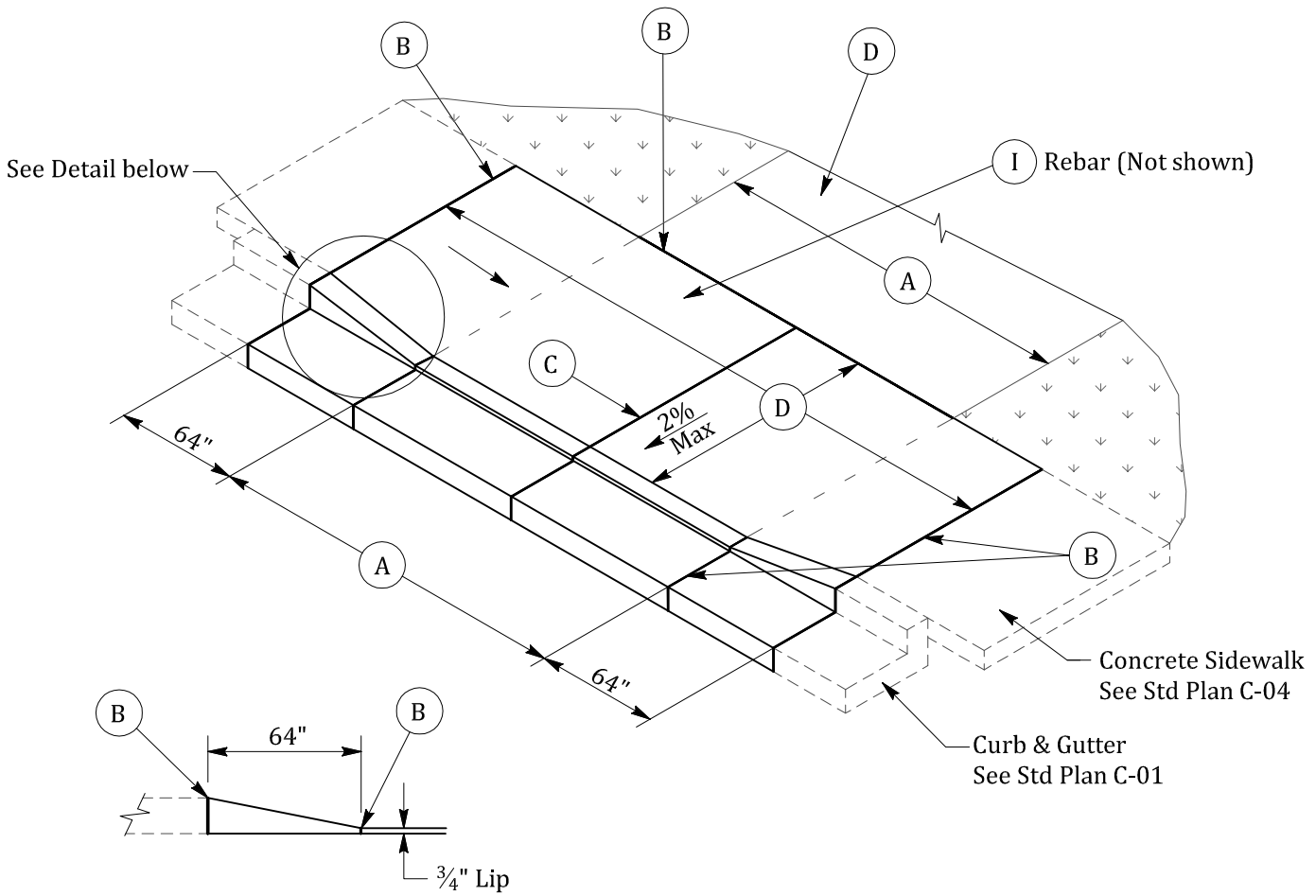

CURB TRANSITION DETAIL

NOTES:

- (A) Equals width of Driveway at property line, minimum width 14' min. - 30' max for residential and 25' min. - 35' max for commercial.
- (B) 1/2" wide full depth Expansion Joint.
- (C) Full depth Expansion Joint if (A) is 15' or greater.
- (D) Driveway to be surfaced with asphalt or concrete.
- (E) Driveway concrete shall be a Minimum of 6" thick for Residential & 8" thick for Commercial locations and is to be placed on a minimum of 4" Class II Aggregate Base 95% maximum compaction, ASTM D1557. Over 95% compacted subgrade.
- (F) All concrete shall be per current Caltrans Specifications Section 73 "Concrete Curbs and Sidewalks" and Section 90 "Concrete". Concrete shall include two (2) pounds of liquid lamp black per cubic yard of concrete. Liquid lamp black color shall be "Davis A 8090 Black" or equal.
- (G) Sawcut and remove 18" minimum street section for driveway installation in existing streets.
- (H) All work shall conform to current ADA requirements.
- (I) #4 Rebar 16" O.C. both ways minimum 3" cover.

NOT TO SCALE

APPROVED BY	DATE		CONCRETE DRIVEWAY WITHOUT PLANTER	STD. PLAN NO.
 CITY ENGINEER	APRIL 2017 Rev. 4/19/17			

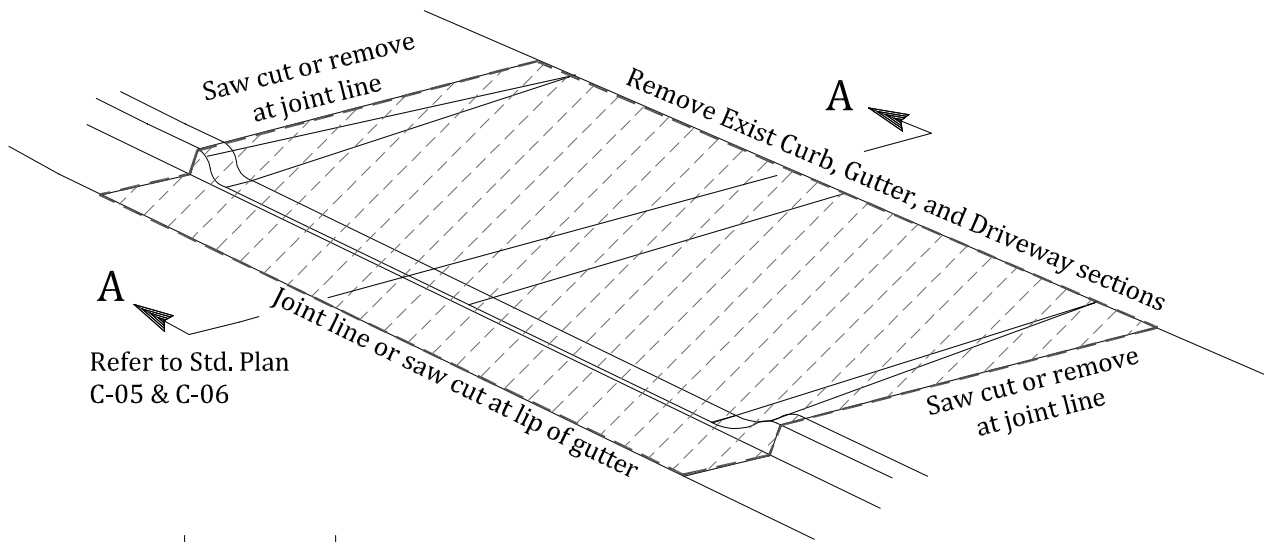

Refer to Std. Plan
C-05 & C-06

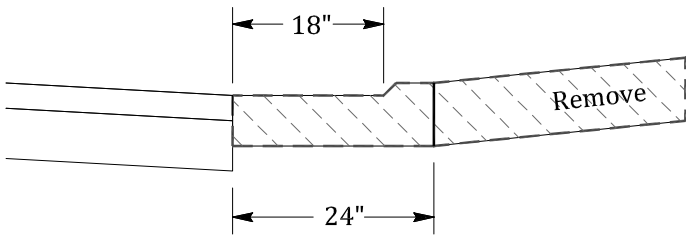

SECTION A-A

NOTE:
Rebar: #4 @ 16" O.C. both ways, Min 3"
concrete coverage

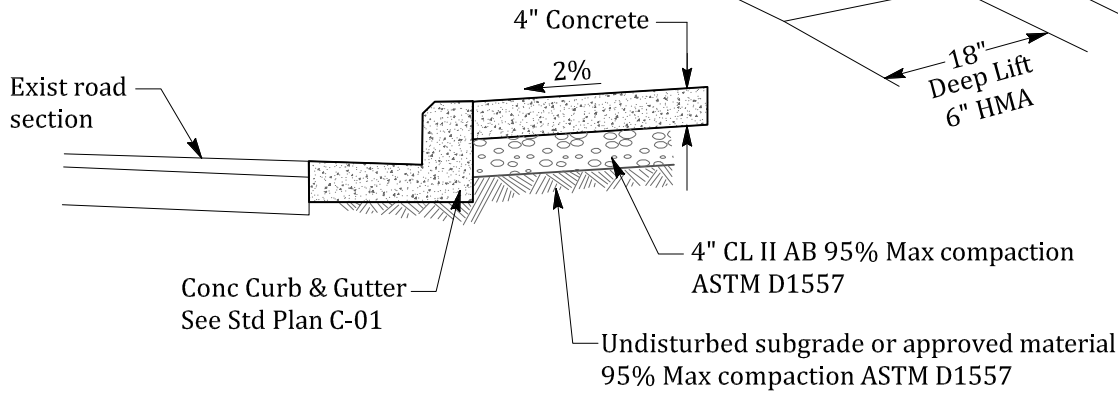
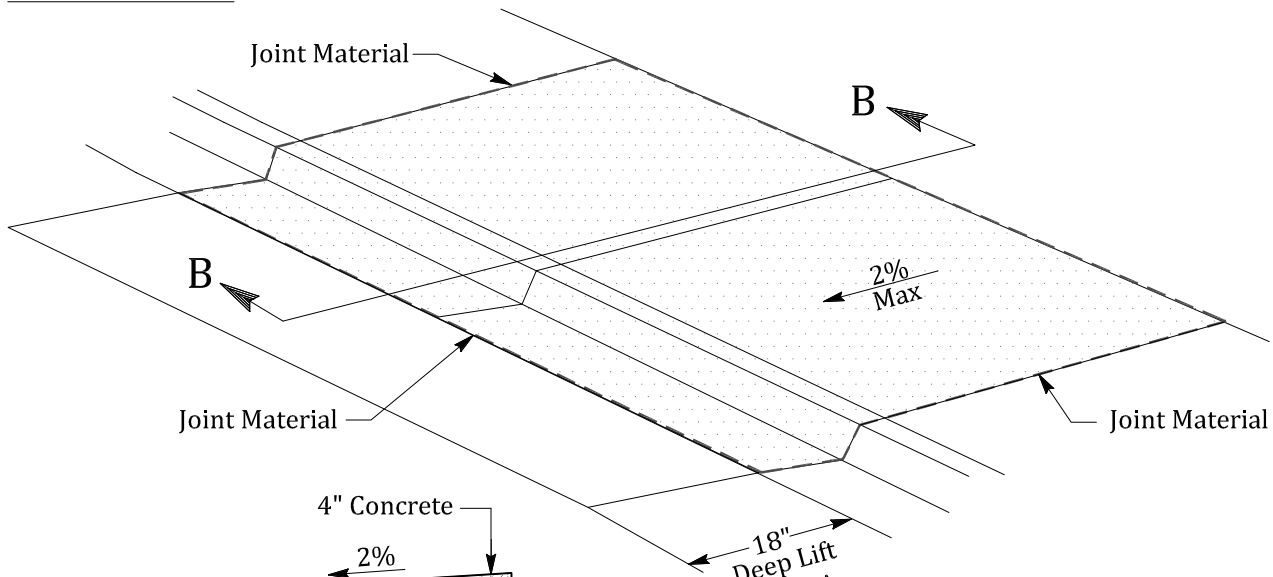

SECTION B-B

NOT TO SCALE

APPROVED BY	DATE		CONCRETE DRIVEWAY TO SIDEWALK RECONSTRUCTION	STD. PLAN NO.
 CITY ENGINEER	JUNE 2016			C-07

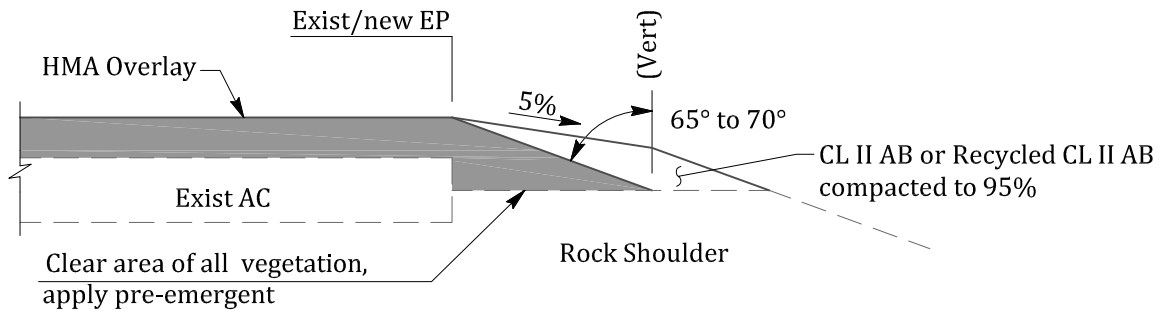

NOTES:

1. Safety edges shall be used on all roads posted 35 mph or higher with paved shoulders 4' or less.
2. Construct safety edge in conformance with project special provisions or City of Oakley Public Works Department Standard Provision for Construction.

SAFETY EDGE

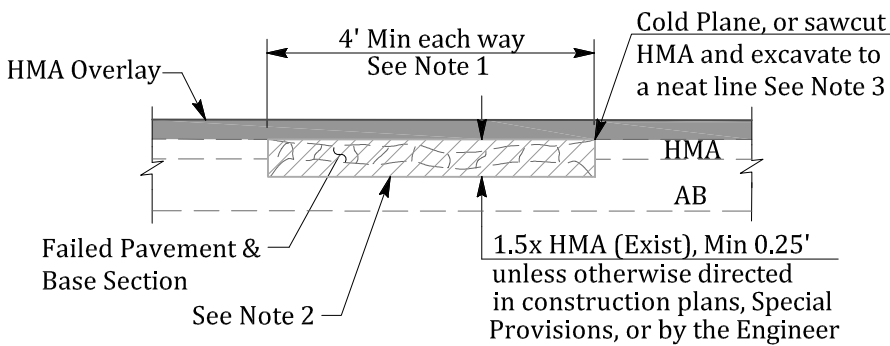

PAVEMENT FAILURE REPAIR DETAIL

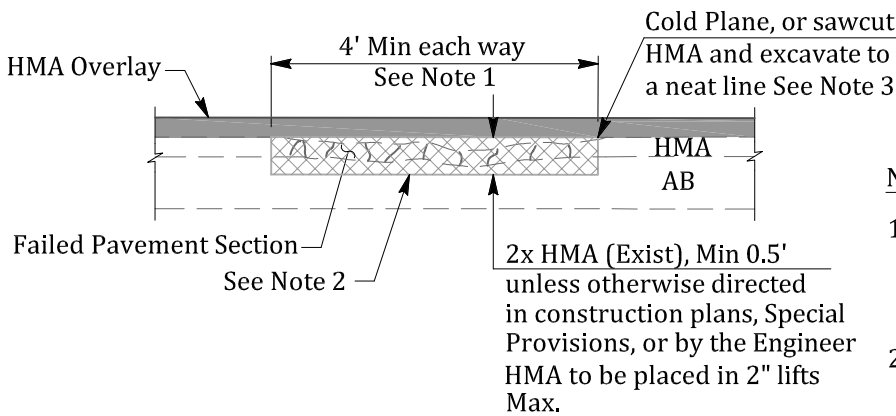

HMA = Hot Mix Asphalt

NOTES:

1. Limits of pavement failure repairs and base failure repairs shall be as marked in the field by the Engineer/Inspector.
2. For pavement failure repairs and base failure repairs recompact the existing road base or subgrade to 95% relative density prior to placing HMA.
3. Place paint binder on all vertical cut faces prior to placing HMA.
4. All sawcut /grind joints shall be sealed using paint binder and fine sand.

BASE FAILURE REPAIR DETAIL

NOT TO SCALE

APPROVED BY	DATE		HMA CONFORM DETAILS	STD. PLAN NO.
 CITY ENGINEER	JUNE 2016			C-08

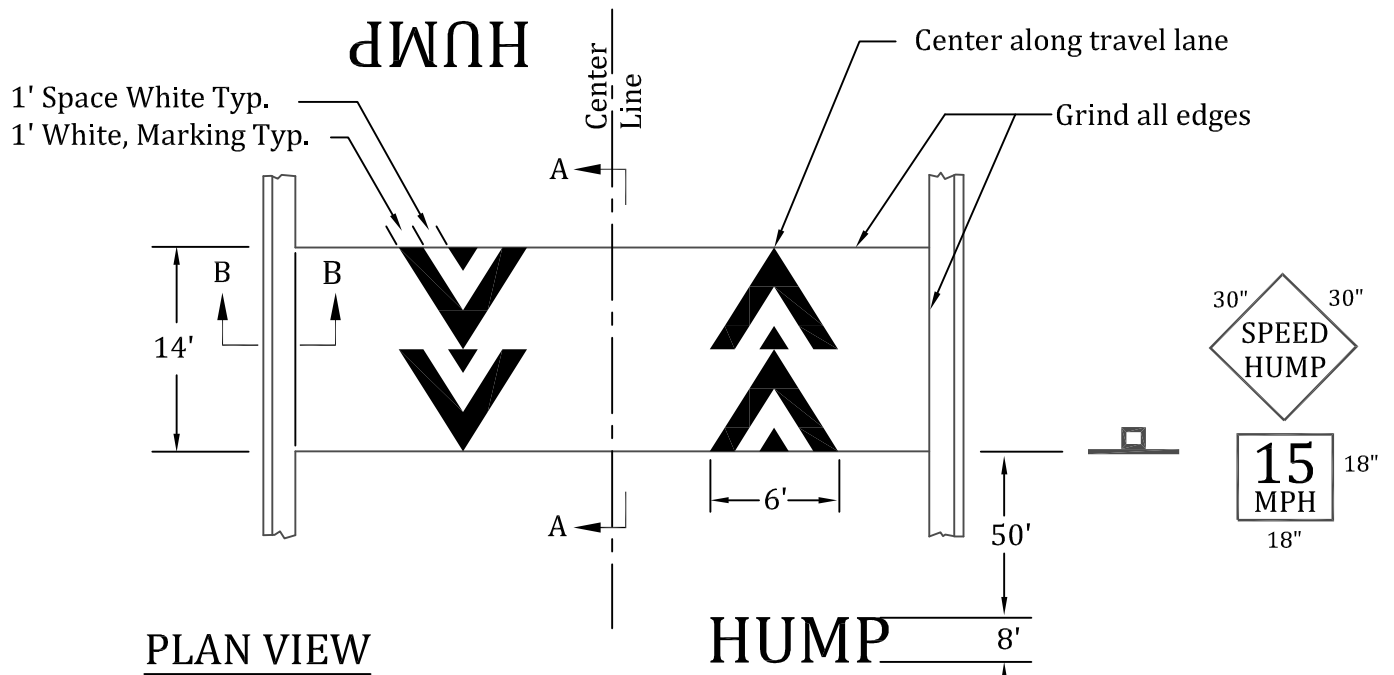

PLAN VIEW

HUMP

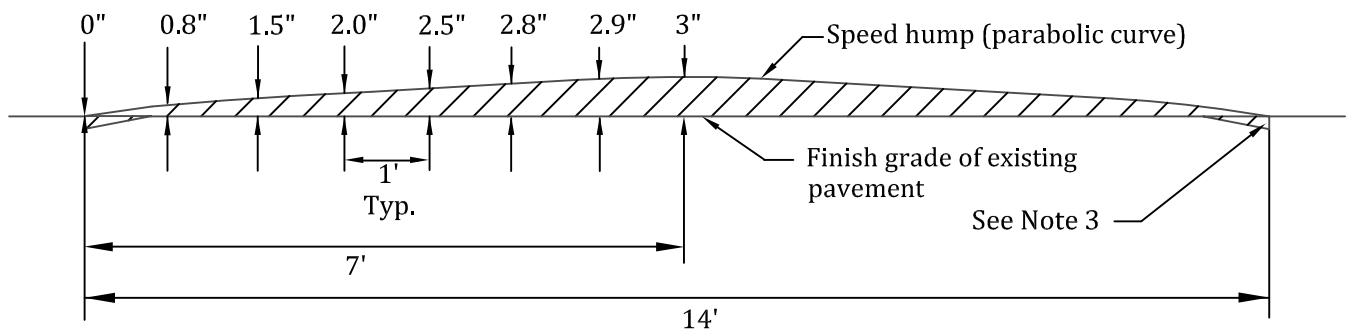

SECTION A-A

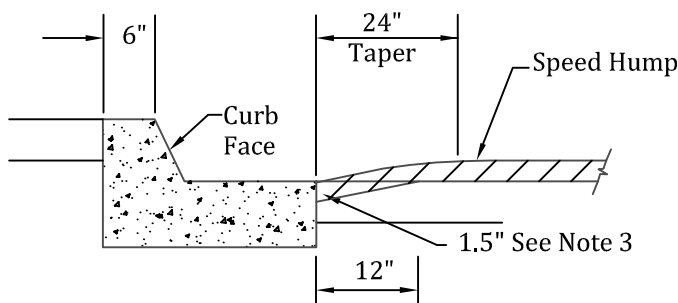

SECTION B-B

NOTES:

1. Speed Hump must be parabolic
2. Type A HMA AR-4000, Max aggregate size $\frac{1}{2}$ ".
3. Grind to key in all edges (1.5" x 12").
4. Signs shown typical in both directions.
5. Sign post must be galvanized square 2"x2" post with $\frac{3}{8}$ " diameter holes spaced 1" apart.
6. Signs shall be 3M Diamond Grade.
7. All striping shall be thermoplastic paint.
8. Speed Hump installation must adhere to the Neighborhood Traffic Management Policy.

NOT TO SCALE

APPROVED BY	DATE		SPEED HUMP	STD. PLAN NO.
	JUNE 2016			C-09
CITY ENGINEER	Rev 6/11/17			

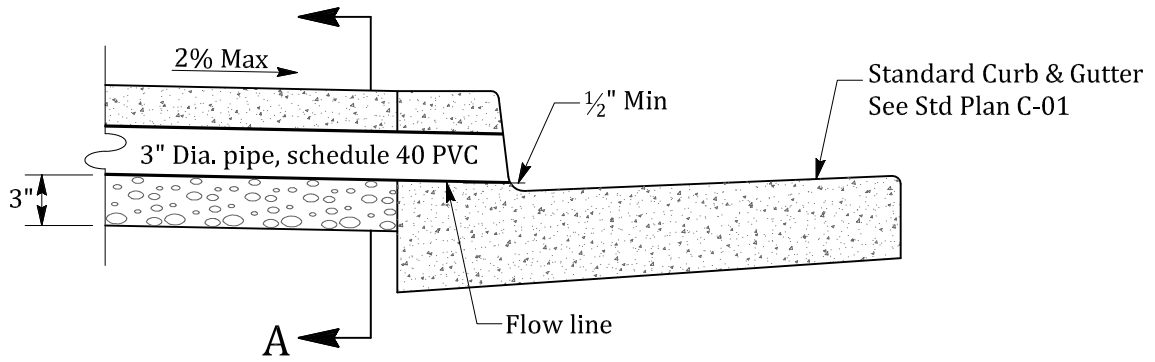

OPTION 1

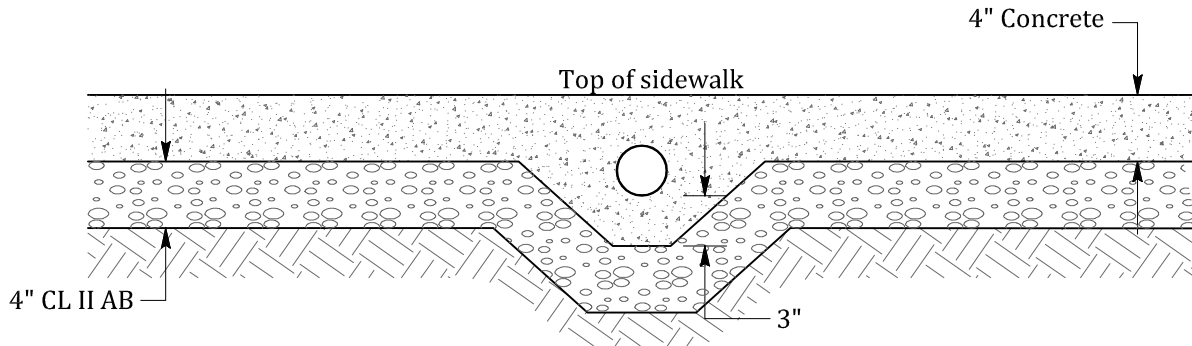

SECTION A-A

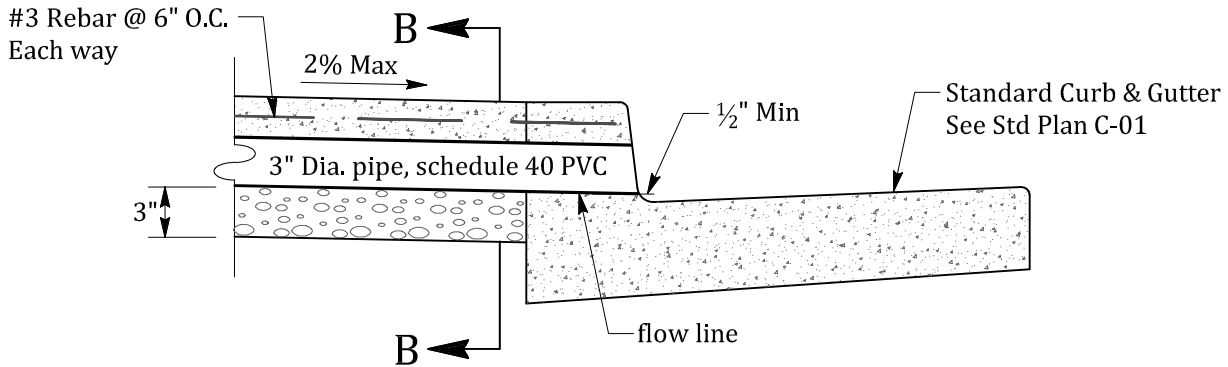

OPTION 2

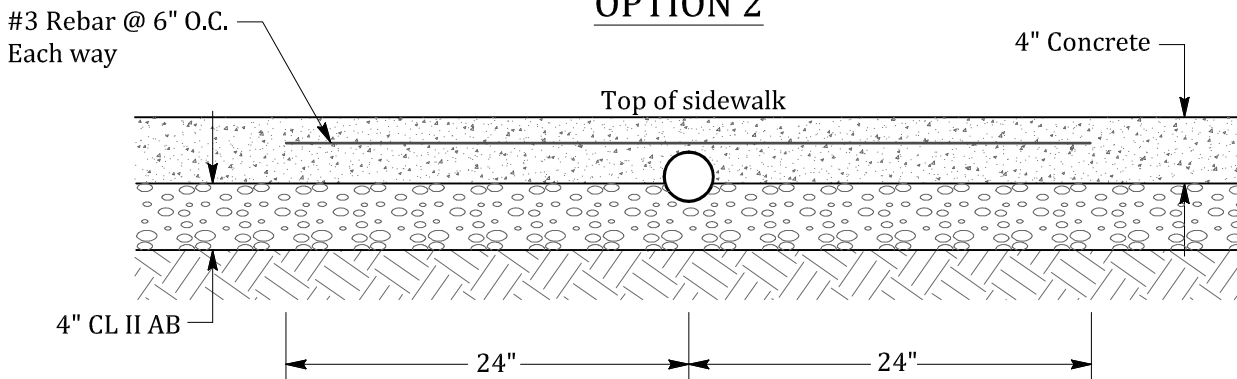

SECTION B-B

NOT TO SCALE

APPROVED BY	DATE		CURB DRAIN	STD. PLAN NO.
	JUNE 2016			SD-01
CITY ENGINEER				

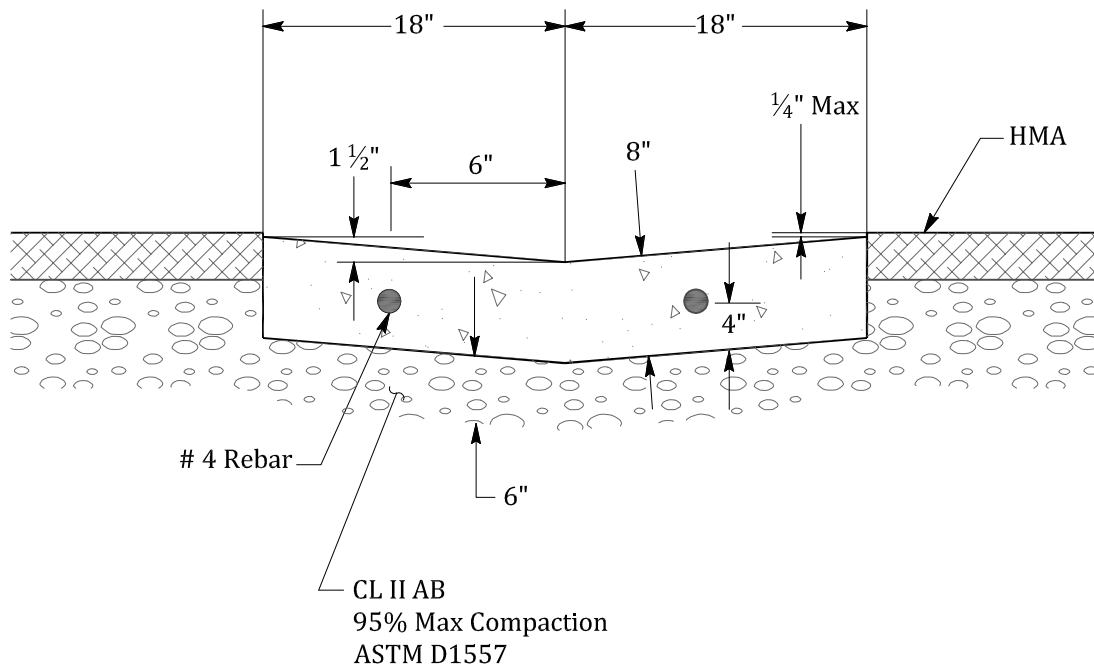

NOTES:

1. Expansion Joints with 1/2" x 12" slip.
2. Dowels at 20 foot intervals.
3. All concrete shall be per current Caltrans Specifications Section 73 "Concrete Curbs and Sidewalks" and Section 90 "Concrete". Concrete shall include two (2) pounds of liquid lamp black per cubic yard of concrete. Liquid lamp black color shall be "Davis A 8090 Black" or equal.

NOT TO SCALE

APPROVED BY	DATE		CONCRETE VALLEY GUTTER	STD. PLAN NO.
	APRIL 2017			SD-02
CITY ENGINEER	Rev. 4/19/17			

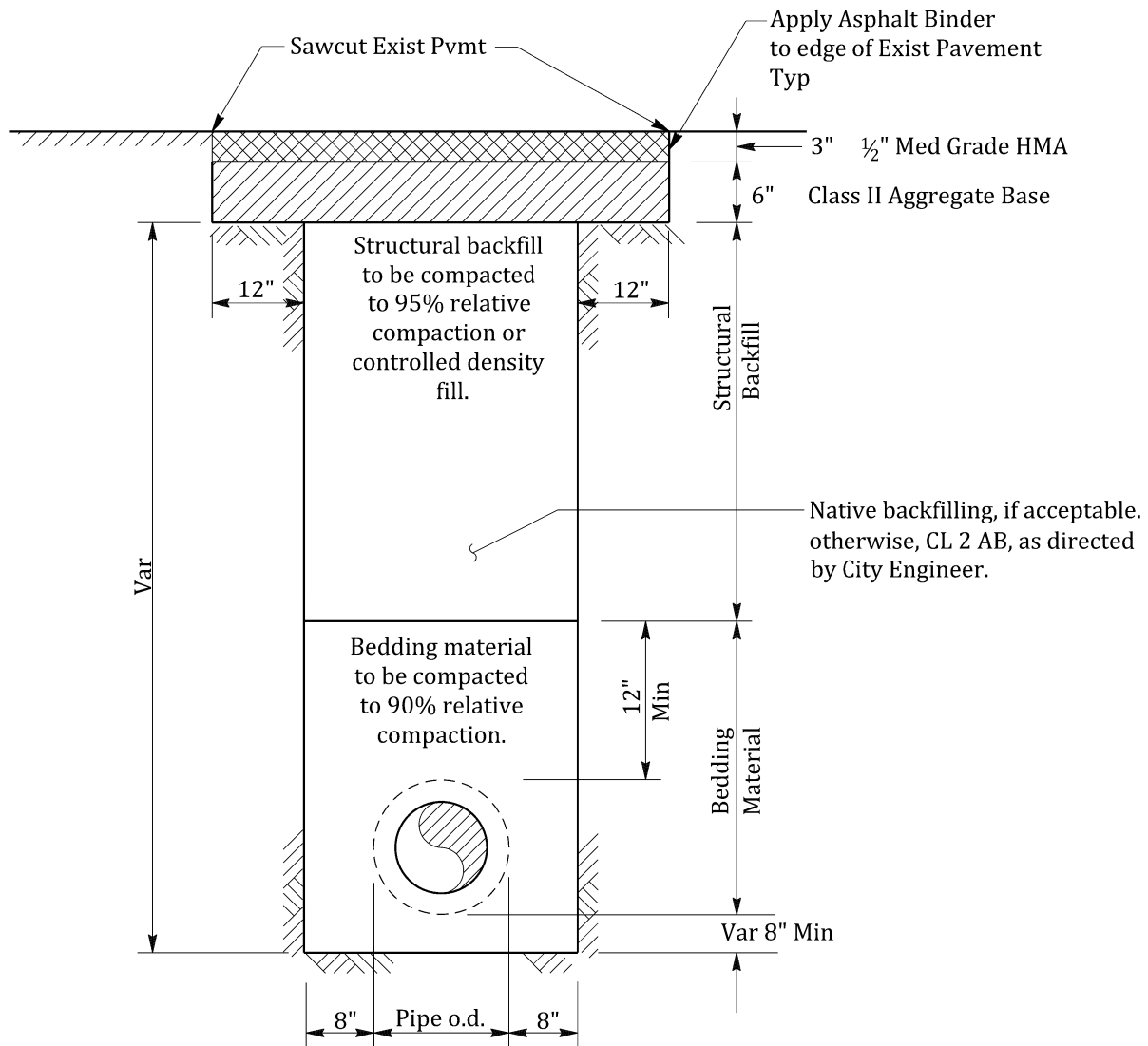

NOTE:

See Standard Plan SD-04 for additional trench requirements.

The 3" HMA shall be placed in two 1.5" lifts.

NOT TO SCALE

APPROVED BY	DATE		PIPE TRENCH DETAIL	STD. PLAN NO.
<i>Keim Robain</i>	JUNE 2016			SD-03
CITY ENGINEER				

BEDDING MATERIAL

Granular bedding material requirements
Caltrans durability index minimum 30

<u>Sieve sizes</u>	<u>Percentage passing</u>
1"	100
3/4"	90-100
3/8"	20-55
#4	0-10
#8	0-5

STRUCTURAL BACKFILL

Structural backfill requirements percent passing
Minimum Sand Equivalent of 20

<u>Sieve sizes</u>	<u>Percentage passing</u>
1-1/2"	100
3/4"	80-100
#4	30-60
#30	5-35
#200	0-12

NOTES:

- | | |
|-------------------------------------------------------------------------------------------------------------------------------------------------------------------------------------------------------------------------------------------------------------------------------------------------------------------------------------------------------------------------------------------------------------------------------------------------------------------------------------------------------------------------------------------------------------------------------------------------------------------------------------------------------------------------------------------------------------------------------------------------------------------------------------------------------------------------------------------------------------------------------------------------------------------------------------------------------------------------------------------------------------------------------------------------------------------------------------------------------------------------------------------------------------------------------------------------------------------------------------------------------------------------------------------------------------------------------------------------------------------------------------------------------------------------------------------------------------------------------------------------------------------------------------------------|--------------------------------------------------------------------------------------------------------------------------------------------------------------------------------------------------------------------------------------------------------------------------------------------------------------------------------------------------------------------------------------------------------------------------------------------------------------------------------------------------------------------------------------------------------------------------------------------------------------------------------------------------------------------------------------------------------------------------------------------------------------------------------------------------------------------------------------------------------------------------------------------------------------------------------------------------------------------------------------------------------------------------------------------------------------------------------------------------------------------------------------------------------------------------------------------------------------------------------------------------------------------------------------------------------------------------------------------------------------------------------------------------------------------------------------------------------------------------------------------------------------------------------------------------------------------------------------------|
| <ol style="list-style-type: none"> 1. All backfill material shall be placed in lifts not to exceed 6 inches before compaction unless authorized by the City Engineer. 2. Mechanical compaction of backfill material shall not begin until the depth of compacted backfill material is 2 feet above the top of pipe. 3. Each lift shall be mechanically compacted to the required density prior to placing succeeding lifts of backfill material. 4. Compaction tests shall be as required by the city construction inspector, but in no case less than 2 tests every 200 feet of trench. 5. In-place density will be determined by one or more of the following methods. <ul style="list-style-type: none"> (A) ASTM D1557, test for density of soil in place by the sand cone method. (B) ASTM D2922 - Nuclear Method 6. Laboratory density will be determined by ASTM D1557, Moisture-Density Relations of soils and soil-aggregate mixtures. 7. If the edge of the trench falls within 3 feet of the gutter, the entire pavement shall be removed to the gutter. 8. On steep slopes, construct clay or concrete dam through the bedding material as determined by the City Engineer. 9. For concrete streets place 6 inches of Class A Portland Cement Concrete over 6" of Class II Aggregate Base for finished surface. 10. All trench construction shall be in compliance with latest OSHA Standards. | <ol style="list-style-type: none"> 11. Place permanent pavement within 30 days after backfilling. Install temporary Asphalt Concrete (AC) to finish grade until permanent Hot Mix Asphalt (HMA) is placed. 12. If existing HMA section is less than 4", grind AC to full depth of existing AC and replace full depth of HMA section (3" minimum). 13. In paved streets, all cuts shall be smooth and vertical with the area being generally rectangular. Native material may be used as backfill if approved by City Engineer. If sand backfill is used, it must be well graded, tamped with vibratory compactor and lightly jetted, if needed. 14. A semi-finished surface of cutback or lowered cross-section (Max lowered depth, 1/2") of AC will be allowed for a maximum of 15 days after backfilling to allow for settling. Contractor shall patch any time that excessive settling occurs. 15. Within 15 days, Contractor shall restore surface to its original condition and be responsible for any further settling or failure for a minimum of 2 years. If cutback is used as a semi-finished surface, it shall be removed before finishing. A 6 inch edge of existing AC shall be removed around the perimeter of the cut before placement of HMA. 16. A 6 inch course of CL II AB and 3 inch HMA is minimum surface to be restored. No restoration shall be less substantial than existing composition. In cases of concrete streets, a 6 inch thickness of concrete on a 6 inch CL II AB is the minimum standard. |
|-------------------------------------------------------------------------------------------------------------------------------------------------------------------------------------------------------------------------------------------------------------------------------------------------------------------------------------------------------------------------------------------------------------------------------------------------------------------------------------------------------------------------------------------------------------------------------------------------------------------------------------------------------------------------------------------------------------------------------------------------------------------------------------------------------------------------------------------------------------------------------------------------------------------------------------------------------------------------------------------------------------------------------------------------------------------------------------------------------------------------------------------------------------------------------------------------------------------------------------------------------------------------------------------------------------------------------------------------------------------------------------------------------------------------------------------------------------------------------------------------------------------------------------------------|--------------------------------------------------------------------------------------------------------------------------------------------------------------------------------------------------------------------------------------------------------------------------------------------------------------------------------------------------------------------------------------------------------------------------------------------------------------------------------------------------------------------------------------------------------------------------------------------------------------------------------------------------------------------------------------------------------------------------------------------------------------------------------------------------------------------------------------------------------------------------------------------------------------------------------------------------------------------------------------------------------------------------------------------------------------------------------------------------------------------------------------------------------------------------------------------------------------------------------------------------------------------------------------------------------------------------------------------------------------------------------------------------------------------------------------------------------------------------------------------------------------------------------------------------------------------------------------------|

NOT TO SCALE

APPROVED BY	DATE		<h2 style="margin: 0;">PIPE TRENCH NOTES</h2>	STD. PLAN NO.
<i>Kevin Rolan</i>	JUNE 2016			SD-04
CITY ENGINEER				

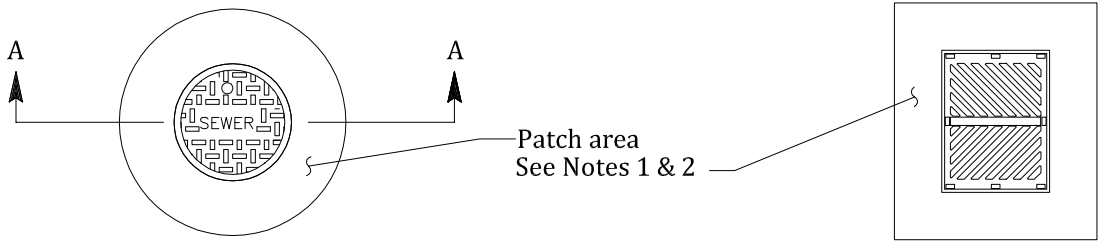

Patch area
See Notes 1 & 2

PLAN

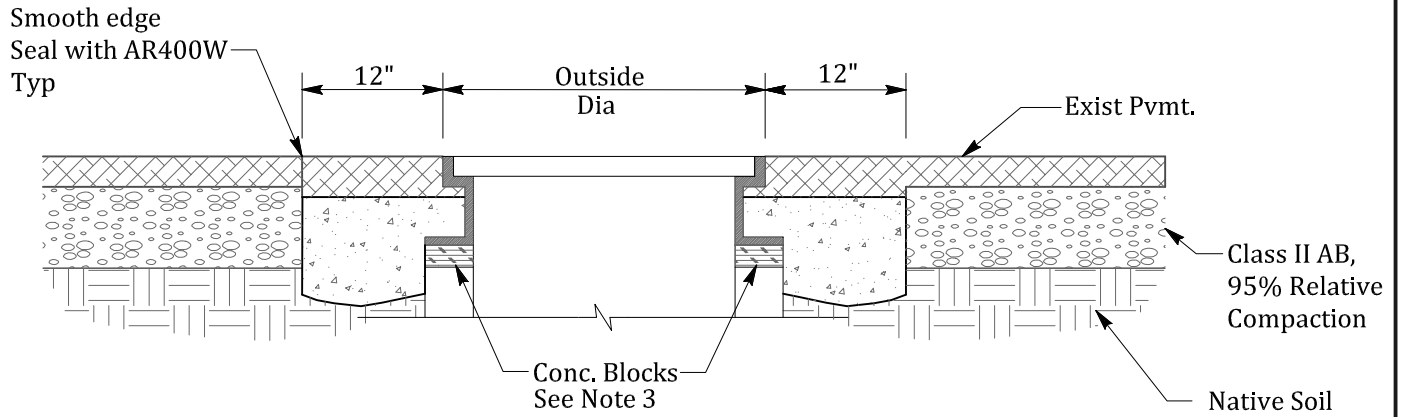

SECTION A-A

MANHOLE & CATCH BASIN ADJUSTMENT

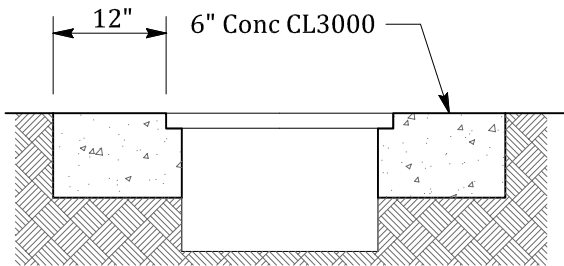

OUTSIDE PAVED AREA

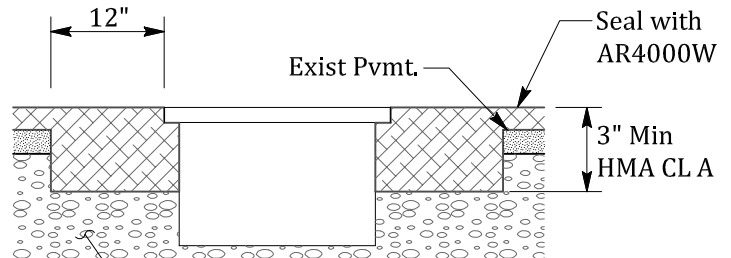

INSIDE PAVED AREA

VALVE BOX ADJUSTMENT

NOTES:

1. Remove pavement and base materials for a distance which is equal to the diameter of the frame plus two (2) feet. Adjust casting frame to new pavement surface using concrete blocks.
2. Asphalt concrete Class "B" (3" Min) replacement patch to be 1" thicker than previously existed. The rest of the backfill to be controlled density fill.
3. 2" x 4" x 8" solid brick used for final adjustment to grade. 6" high Maximum.

NOT TO SCALE

APPROVED BY	DATE		MANHOLE/CATCH BASIN & VALVE BOX ADJUSTMENT	STD. PLAN NO.
 CITY ENGINEER	JUNE 2016			SD-05

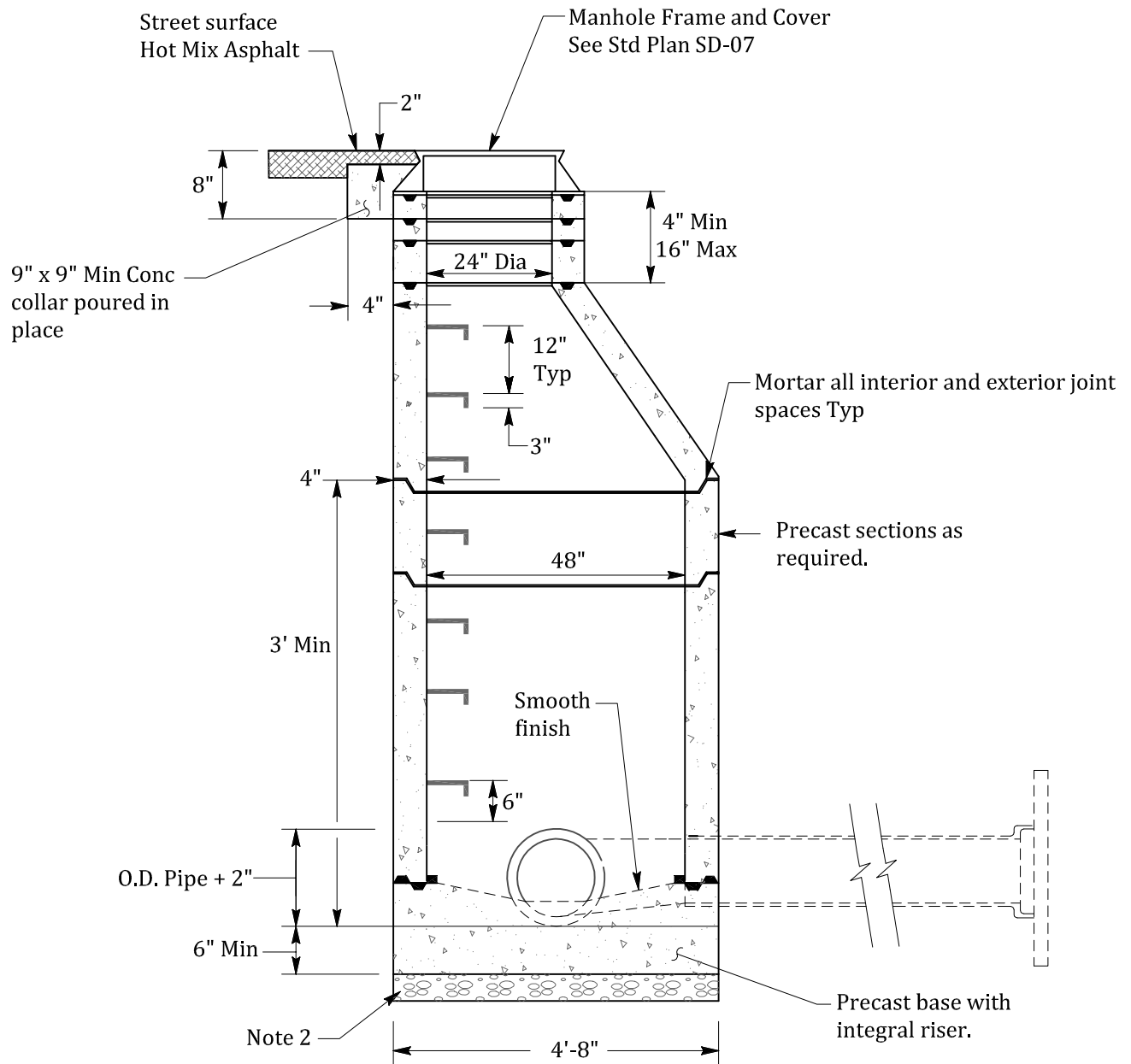

NOTES:

1. Precast Manhole sections shall conform to applicable provisions of ASTM C478.
2. 9" Class II for Aggregate Base bedding compacted to 95% maximum ASTM D1557.
3. Steps shall be Galvanized Steel 3/4" diameter inserted 3" minimum.
4. All joints with flexible plastic Joint Compound (Ram-Neck, Quick Seal, or equal). two layers may be required to seal base. plaster with mortar thereafter.
5. Manhole base must be poured against undisturbed soil. If excavated too deep, fill with concrete.

NOT TO SCALE

APPROVED BY	DATE		STANDARD MANHOLE	STD. PLAN NO.
 CITY ENGINEER	JUNE 2016 Rev. 6/30/17			SD-06

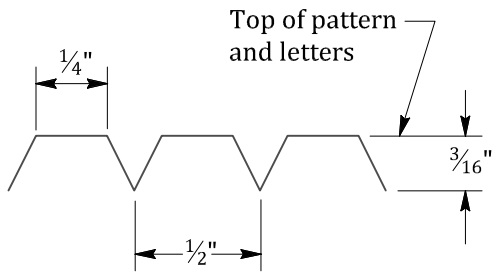

DIAMOND COVER PATTERN DETAIL

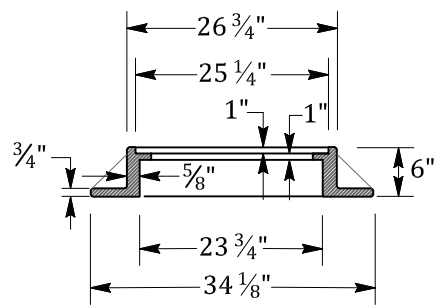
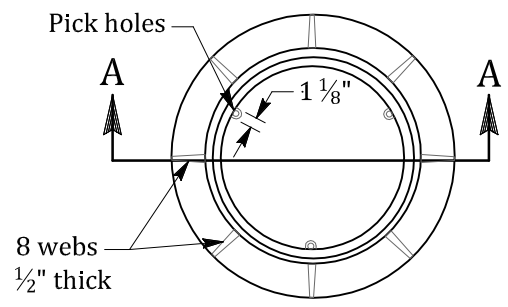
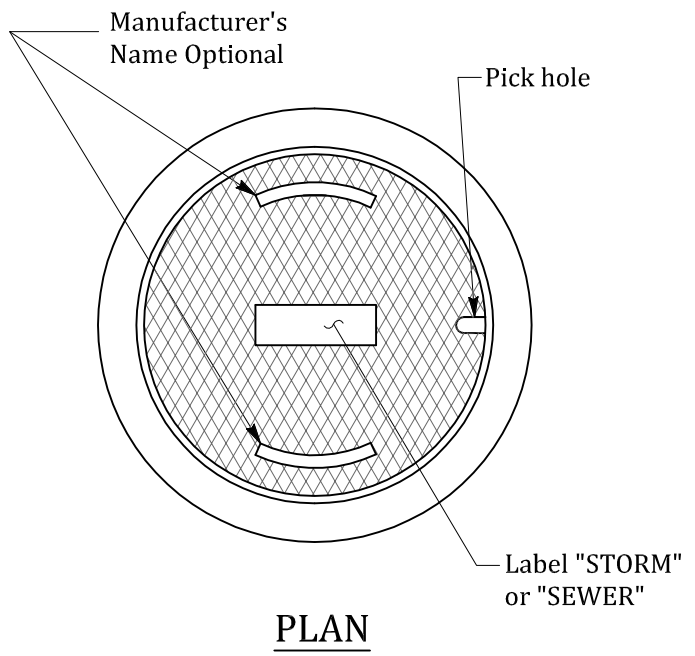

SECTION A-A

NOT TO SCALE

APPROVED BY	DATE		MANHOLE FRAME AND COVER	STD. PLAN NO.
	JUNE 2016			SD-07
CITY ENGINEER				

Bicycle Safe Grate
 Frame and Grate
 2" x 3/16" Reticuline
 Bars Typ See
 Std Plan SD-11

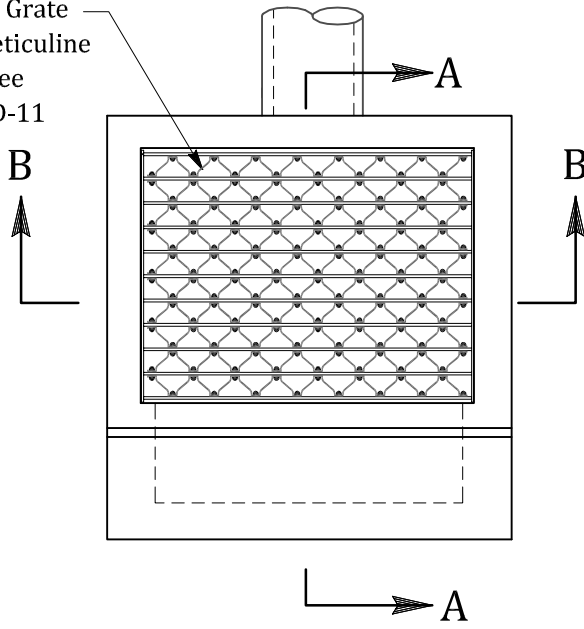

PLAN

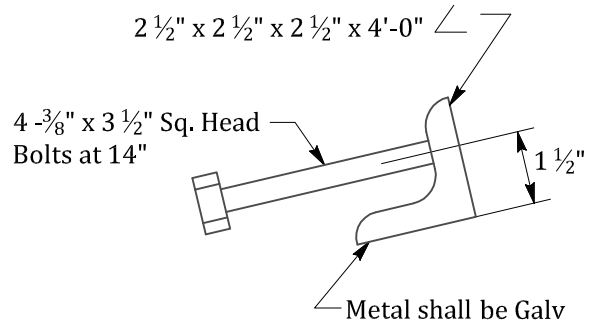

ANGLE ANCHOR

NOTE:

Where Inlet is located within a return, angle anchor shall be curved to match face of curb radius.

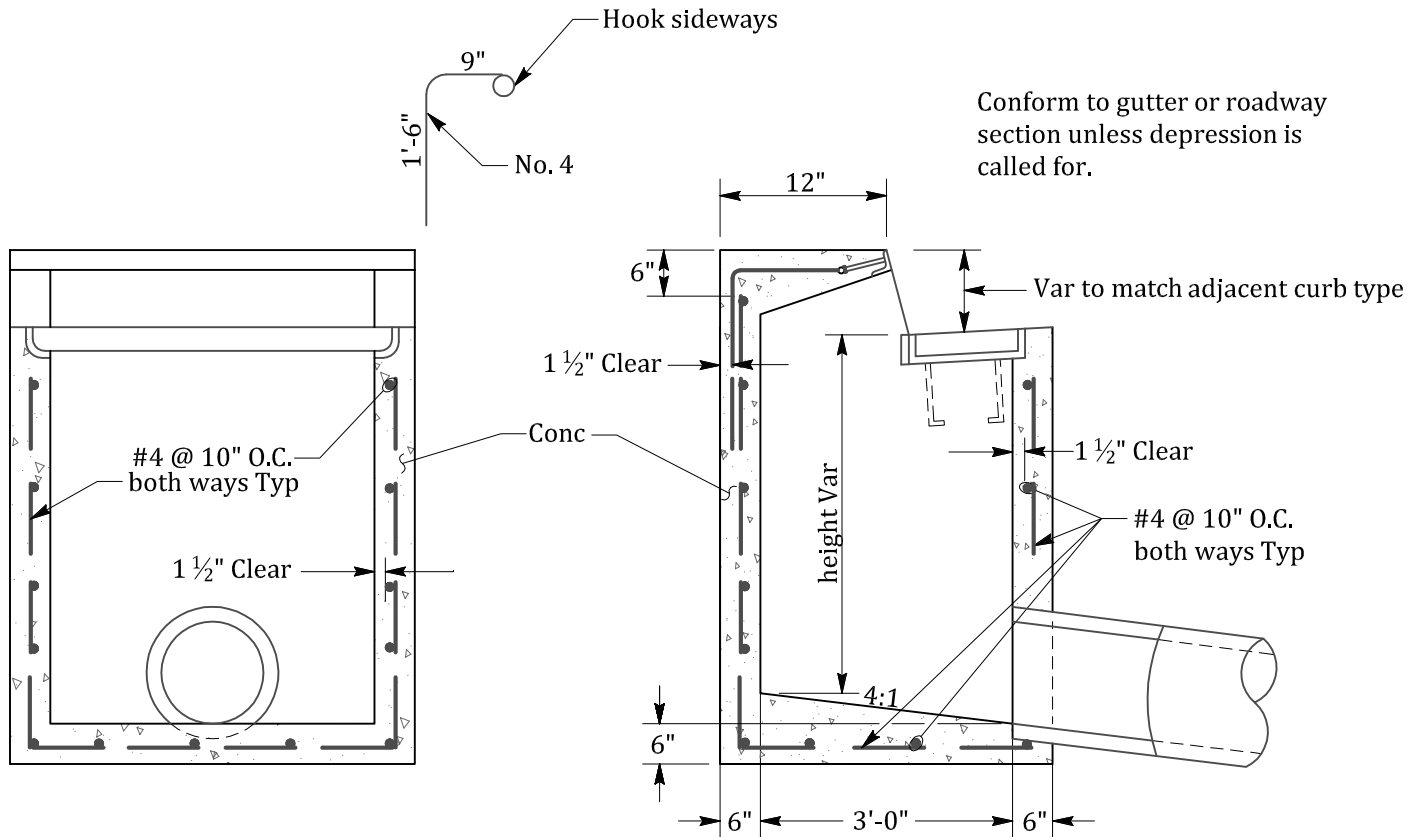

SECTION B - B

SECTION A - A

NOT TO SCALE

APPROVED BY	DATE		TYPE I CURB INLET	STD. PLAN NO.
 CITY ENGINEER	JUNE 2016			SD-08

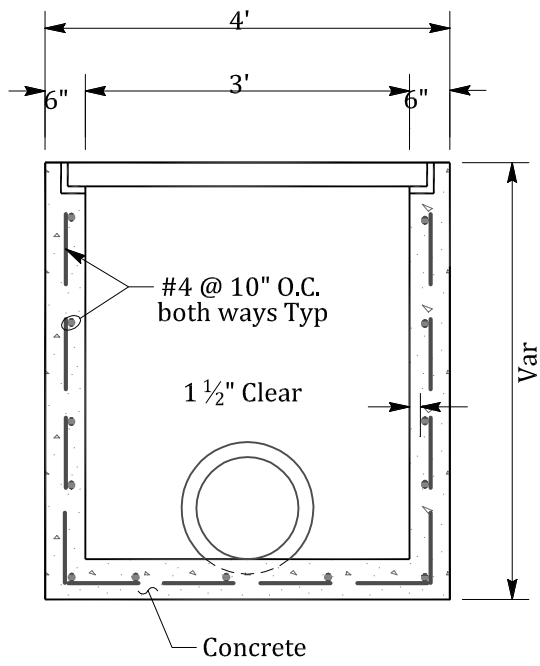
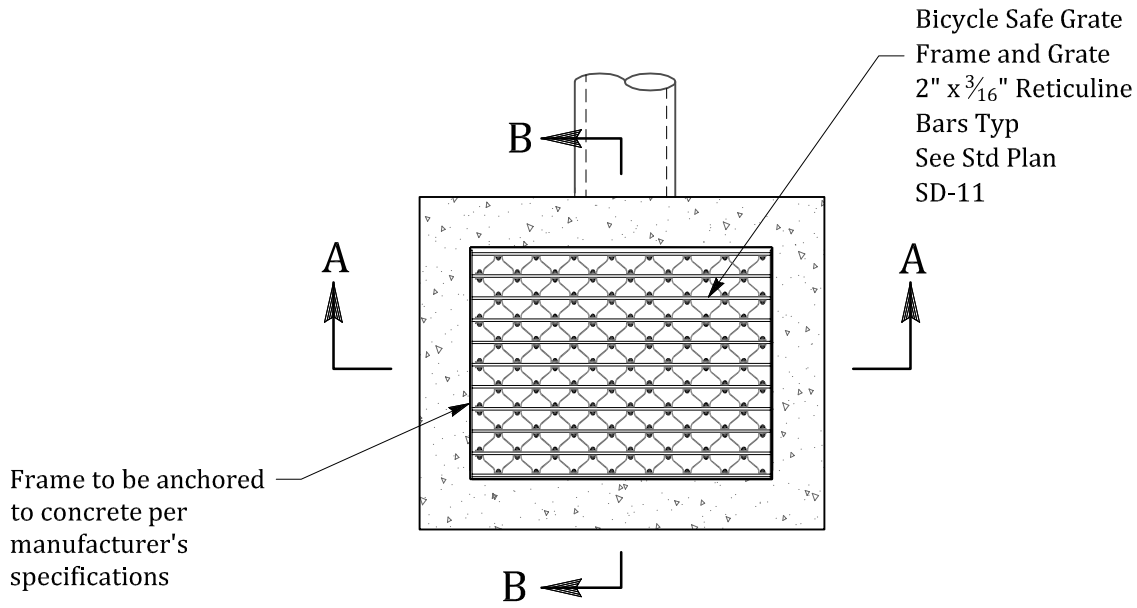

SECTION A-A

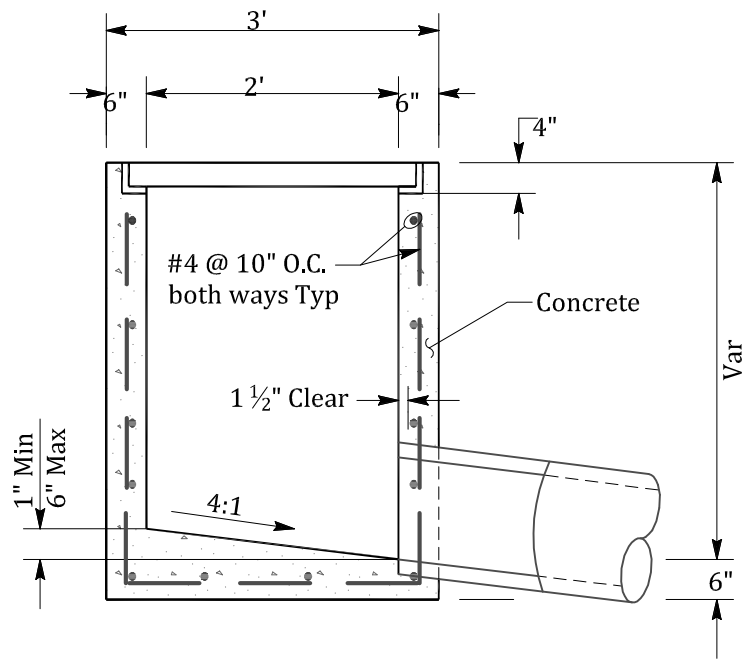

SECTION B-B

NOT TO SCALE

APPROVED BY	DATE		TYPE II INLET	STD. PLAN NO.
 CITY ENGINEER	JUNE 2016			SD-09

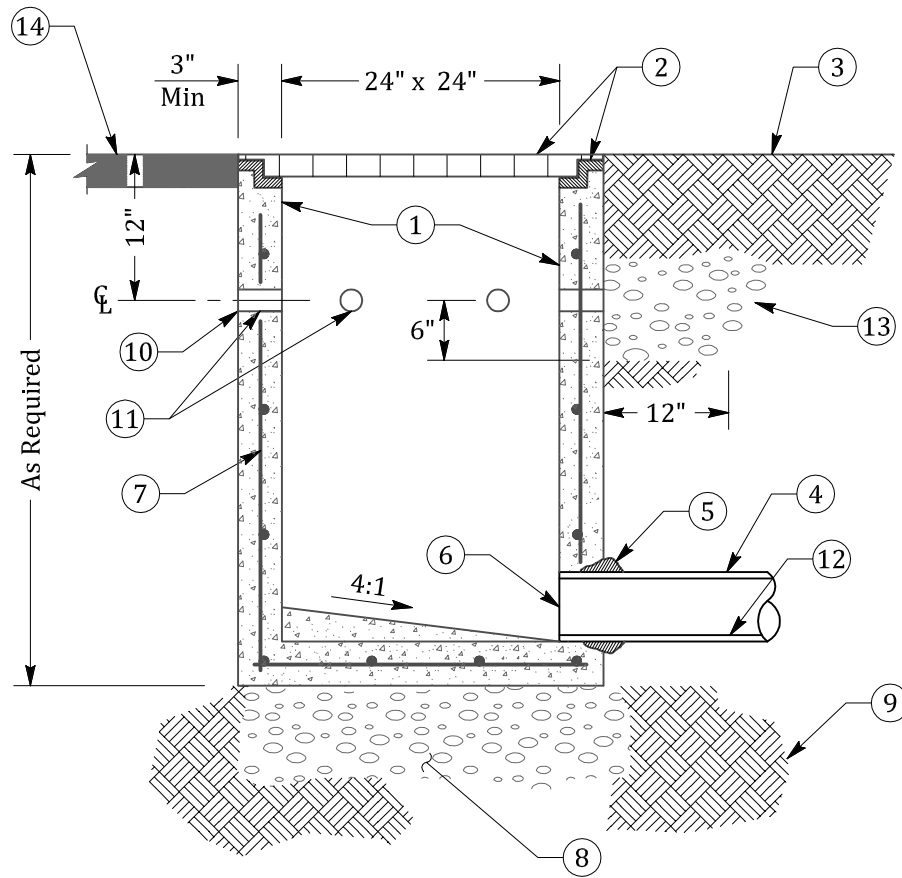

BASIN DETAIL

LEGEND:

- ① Precast concrete basin, per plan.
- ② Grate and frame, w/grate locking device, per plan.
- ③ Finish grade, flush with top of grate
- ④ Storm drain pipe, per plan.
- ⑤ Grout pipe in place.
- ⑥ Pipe openings to be cast into concrete.
- ⑦ Reinforcement per Manufacturer.
- ⑧ Aggregate base, Class II, 9" deep x basin width. Compact to 95% relative density.
- ⑨ Subgrade, compacted to 90% relative density.
- ⑩ At planting areas, 18" wide filter fabric wrapped around & glued at edges to structure where weep holes occur.
- ⑪ At planting areas, 2" weep holes at 10" O.C.
- ⑫ Invert elevation, per plan.
- ⑬ Where weep holes occur surround catch basin with drain rock, 3/4" Diameter Max size, compacted.
- ⑭ Finish surface, where paving occurs.

NOT TO SCALE

APPROVED BY	DATE		TYPE III LANDSCAPE AREA INLET	STD. PLAN NO.
<i>Kevin Rohani</i>	JUNE 2016			SD-10
CITY ENGINEER				

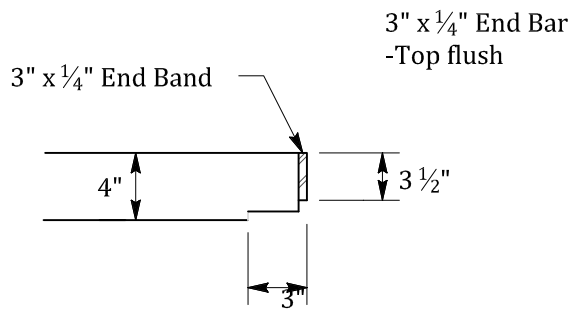

SECTION A - A

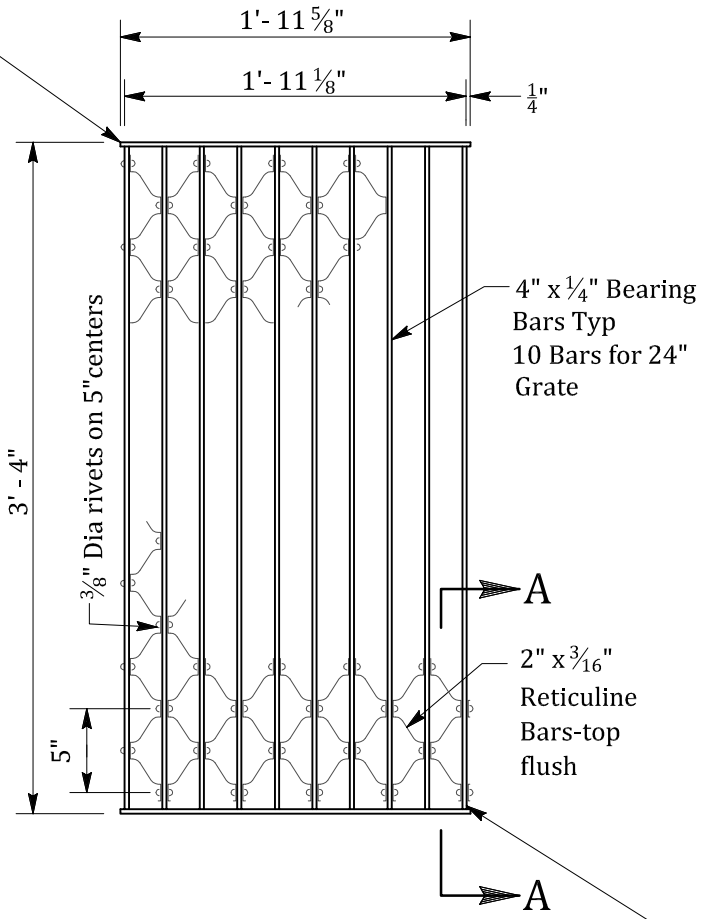

GRATE

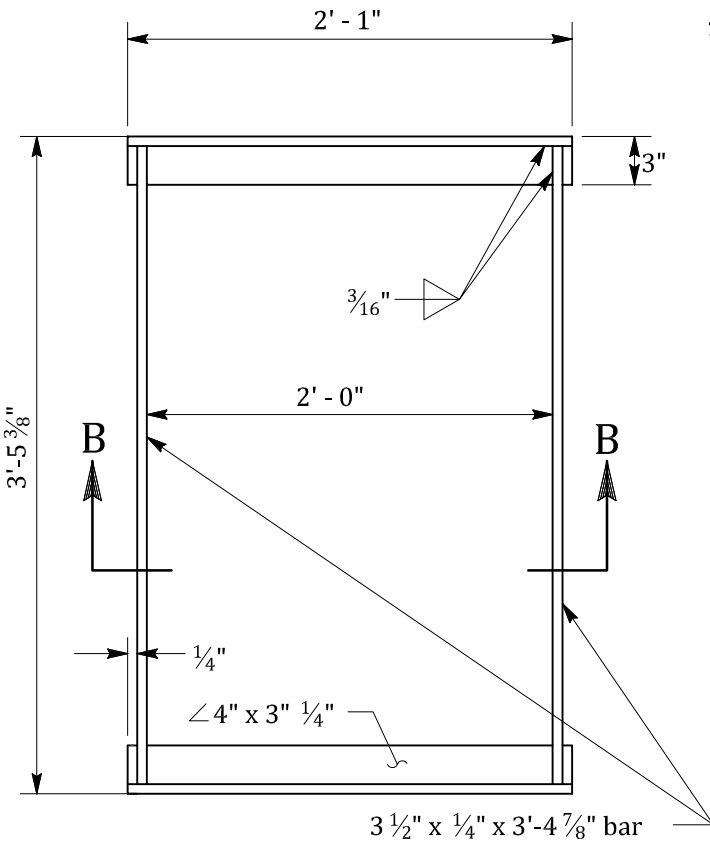

FRAME

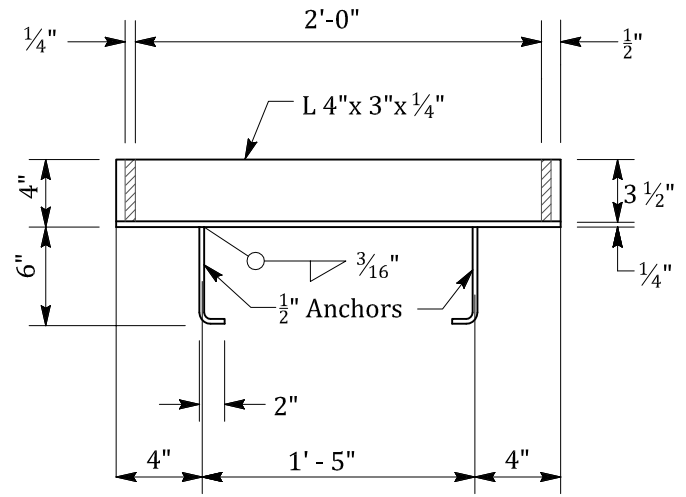

SECTION B - B

NOTES:

1. Hinged Grate only when specified.
2. Place Grate Bars parallel to flow.
3. Frame, Grate, and Anchors shall be galvanized after fabrication.
4. Frame and Grate to be welded steel or approved alternative.

NOT TO SCALE

APPROVED BY	DATE		RETICULINE FRAME & GRATE	STD. PLAN NO.
 CITY ENGINEER	JUNE 2016			SD-11

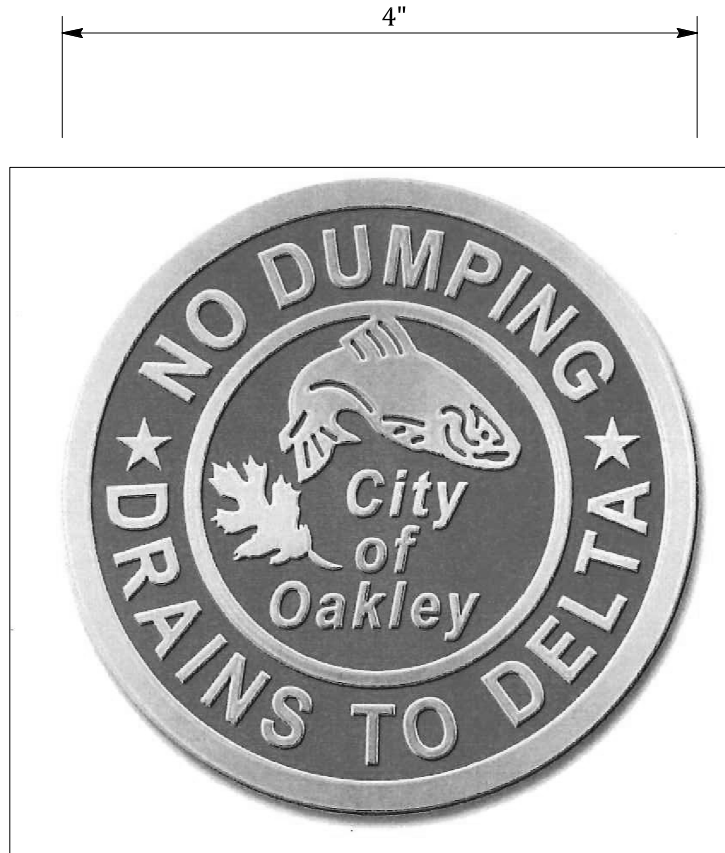

TOP VIEW

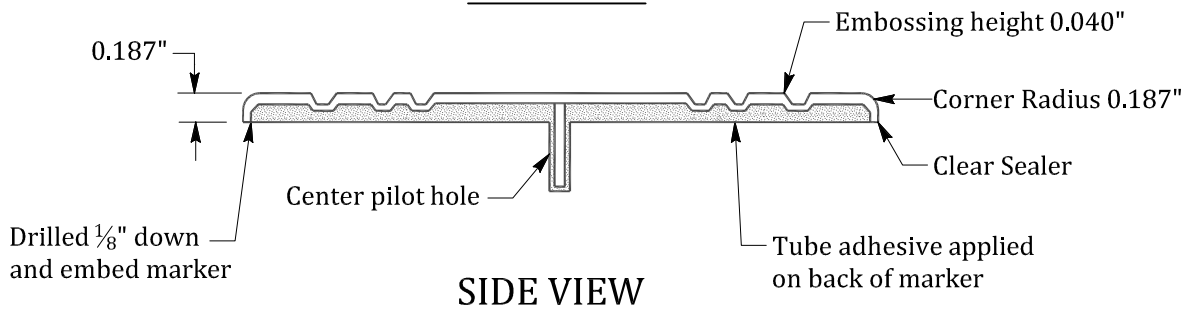

SIDE VIEW

NOTES:

1. Available for purchase at the City of Oakley Public Works Department.
2. Storm Drain marker by Almetek, Item No. STDM-9599-SSP.
3. Sub-surface installation with tube adhesive.
4. Wire brush surface, blow dust, apply adhesive press down.

Hardware:

- SIKS-ADH
Sikaflex 10.1 fl. oz. caulk tube
(1 Tube per 15 markers)
- CDB4
Carbide Drill Bit
- DCG
Dripless caulking gun

NOT TO SCALE

APPROVED BY	DATE		STORM DRAIN MARKER	STD. PLAN NO.
 CITY ENGINEER	JUNE 2016			SD-12

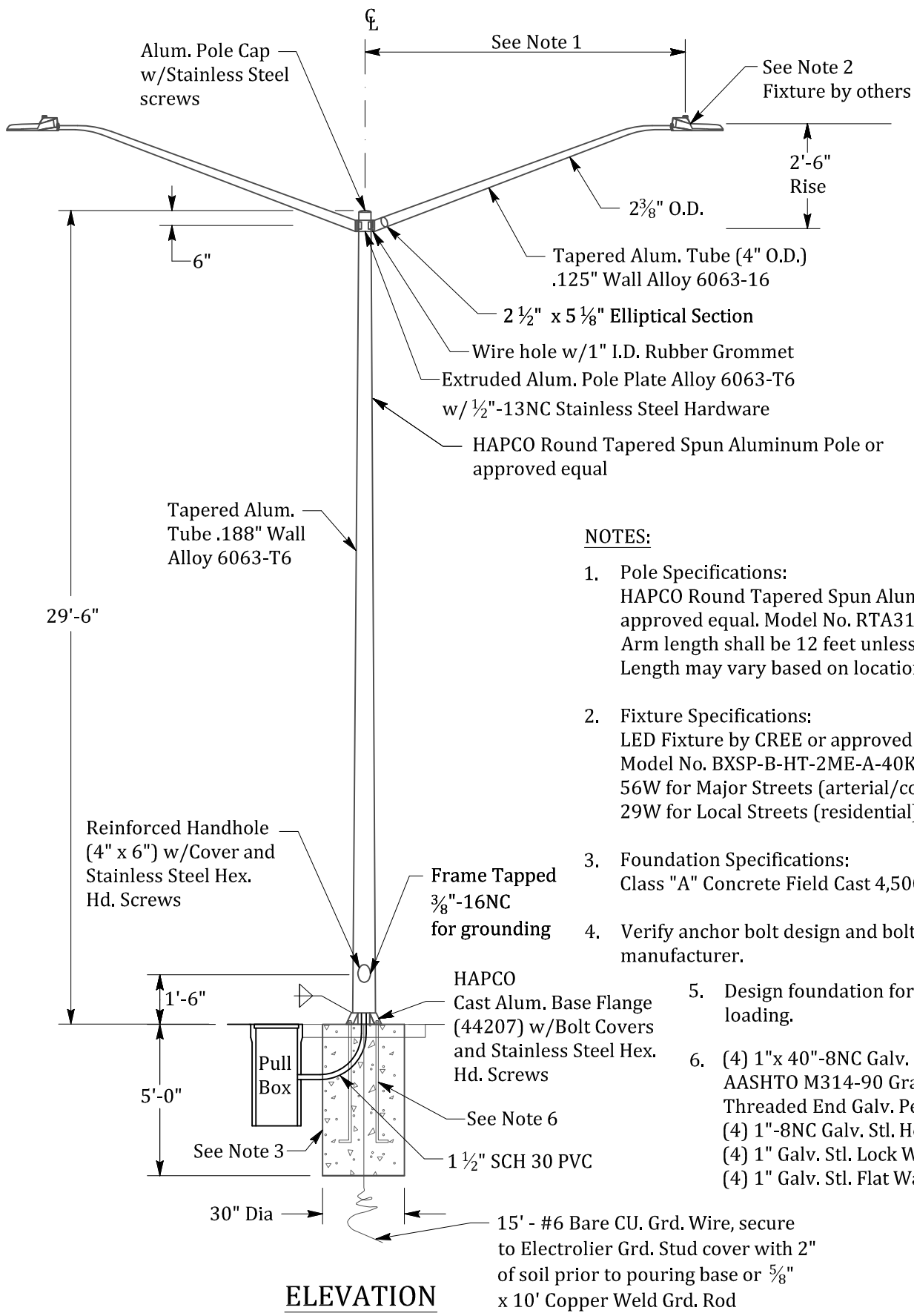

NOTES:

1. Pole Specifications:
HAPCO Round Tapered Spun Aluminum Pole or approved equal. Model No. RTA316D8C4M2C-01
Arm length shall be 12 feet unless noted on the plans.
Length may vary based on location and street type.
2. Fixture Specifications:
LED Fixture by CREE or approved equal.
Model No. BXSP-B-HT-2ME-A-40K-UL-SV-N
56W for Major Streets (arterial/collector)
29W for Local Streets (residential)
3. Foundation Specifications:
Class "A" Concrete Field Cast 4,500 PSI minimum.
4. Verify anchor bolt design and bolt circle with manufacturer.
5. Design foundation for 100 mph wind loading.
6. (4) 1" x 40"-8NC Galv. Stl. Anchor Bolts, AASHTO M314-90 Grade 55, 10" Of Threaded End Galv. Per ASTM A153.
(4) 1"-8NC Galv. Stl. Hex. Nuts
(4) 1" Galv. Stl. Lock Washers
(4) 1" Galv. Stl. Flat Washers

ELEVATION

NOT TO SCALE

APPROVED BY	DATE		STREET LIGHT COBRA HEAD DOUBLE L.E.D.	STD. PLAN NO.
 CITY ENGINEER	JUNE 2016			E-01

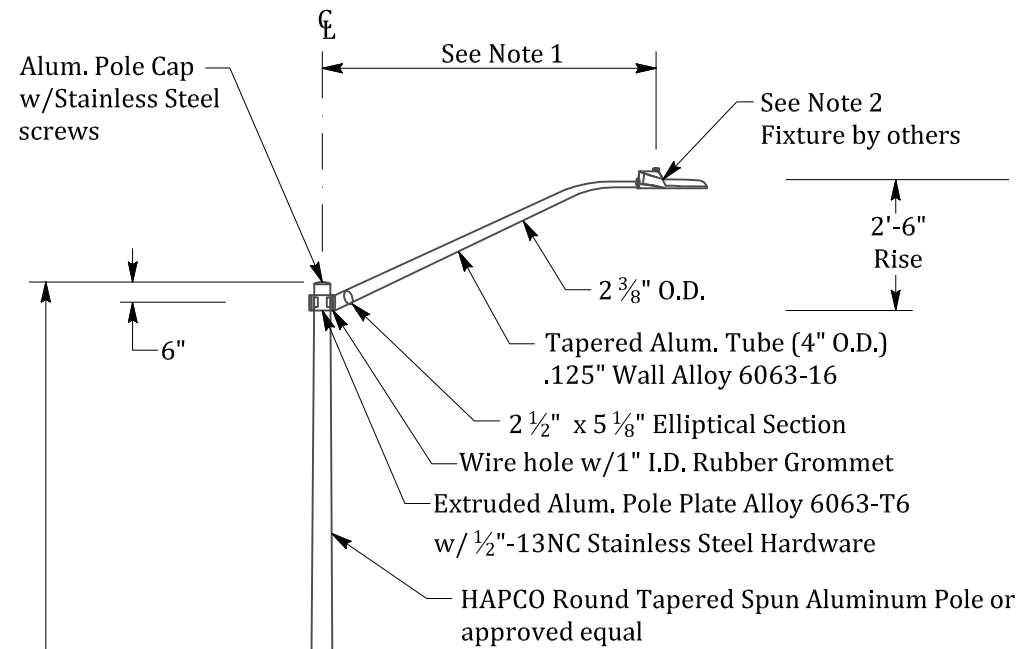

29'-6"

5'-0"

1'-6"

30" Dia

ELEVATION

NOTES:

1. Pole Specifications:
HAPCO Round Tapered Spun Aluminum Pole or approved equal. Model No. RTA316D8C4M1C-01
Arm length shall be 12 feet unless noted on the plans.
Length may vary based on location and street type.
2. Fixture Specifications:
LED Fixture by CREE or approved equal.
Model No. BXSP-B-HT-2ME-A-40K-UL-SV-N
56W for Major Streets (arterial/collector)
29W for Local Streets (residential)
3. Foundation Specifications:
Class "A" Concrete Field Cast 4,500 PSI minimum.
4. Verify anchor bolt design and bolt circle with manufacturer.
5. Design foundation for 100 mph wind loading.
6. (4) 1" x 40"-8NC Galv. Stl. Anchor Bolts, AASHTO M314-90 Grade 55, 10" Of Threaded End Galv. Per ASTM A153.
(4) 1"-8NC Galv. Stl. Hex. Nuts
(4) 1" Galv. Stl. Lock Washers
(4) 1" Galv. Stl. Flat Washers

HAPCO Cast Alum. Base Flange (44207) w/Bolt Covers and Stainless Steel Hex. Hd. Screws

Reinforced Handhole (4" x 6") w/Cover and Stainless Steel Hex. Hd. Screws

1 1/2" SCH 30 PVC

15' - #6 Bare CU. Grd. Wire, secure to Electrolier Grd. Stud cover with 2" of soil prior to pouring base or 5/8" x 10' Copper Weld Grd. Rod

NOT TO SCALE

APPROVED BY	DATE		STREET LIGHT COBRA HEAD SINGLE L.E.D.	STD. PLAN NO.
<i>Kevin Rohan</i>	JUNE 2016			E-02
CITY ENGINEER				

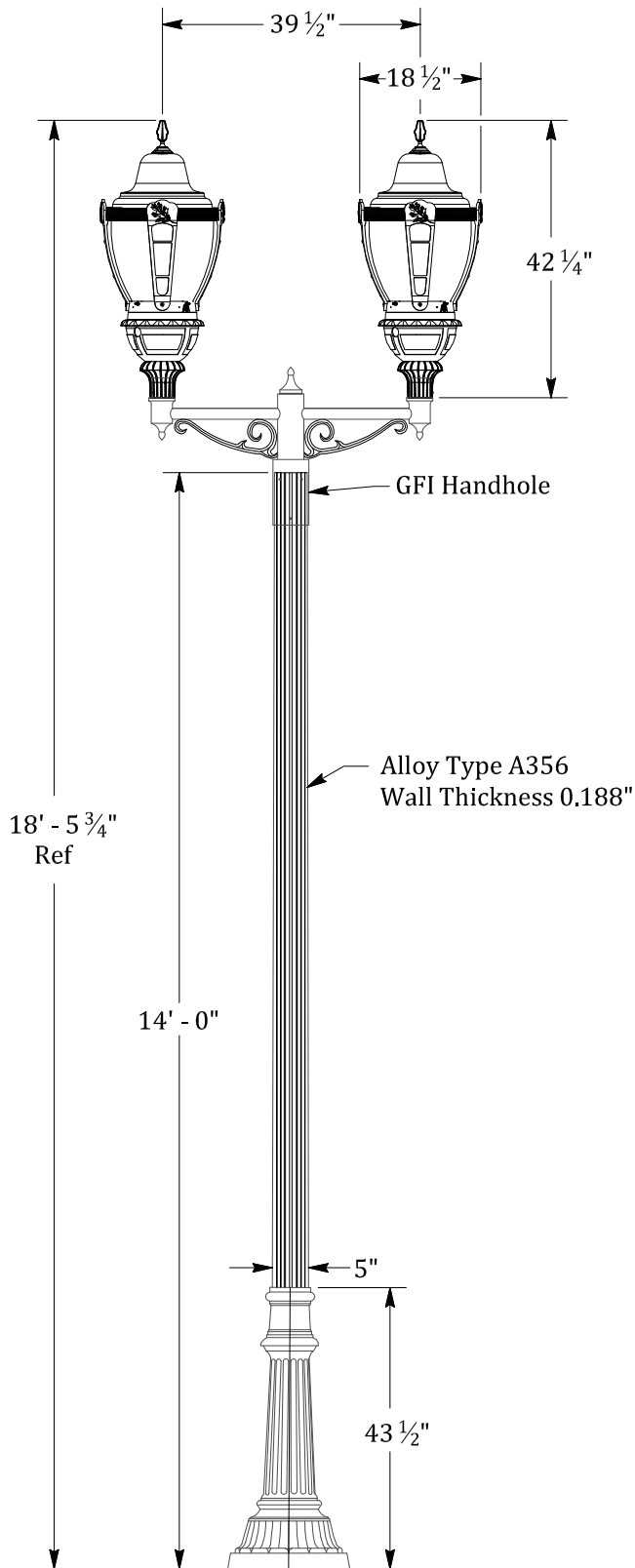

ELEVATION

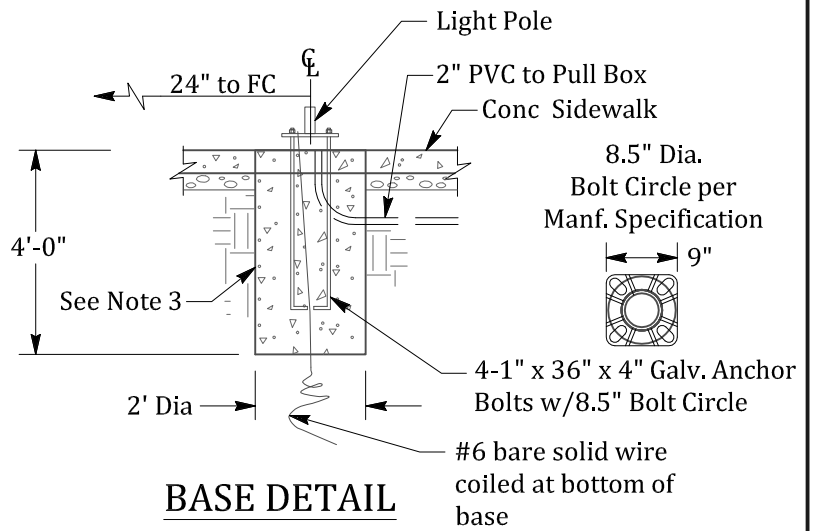

BASE DETAIL

NOTES:

1. Pole Specifications:
BEACON Pole Model No. RSA-B-SHO-F-14-50-B-OT-BBT + VINY/5/BBT w/clam shell base

Pole shall be factory prime coated and electrostatically powdered coated "Black" with the allocation of a 3.5-mil weather resistant powder coat whose base is polyester and thermocured. Base painted both inside and out.
2. Fixture Specifications:
BEACON
(2) Model No. T1/AF/C3 MOD/H2/24NB-55/4K/UNV/DIR3 or DIR4/PCR-TL-7P/BBT+AA-52/5/C/T/FINIAL/BBT

Lens: Acrylic, Frosted
Optics: Type III (residential street)
Type IV (cul de sac)

Light: 24 LED Engine and Drivers Combination
Voltage: 120 Through 277 Volts, 60Hz

Fixture shall be SiteSync ready to include plug in daughter board or approved equal

Fixture shall be NRTL Listed for Wet Location.
Fasteners shall be stainless steel.
3. Foundation Specifications:
Class "A" Concrete Field Cast 2,500 PSI minimum @ 28 Days.
4. Verify anchor bolt design and bolt circle with manufacturer.
5. Design foundation for 100 mph wind loading.
6. Decorative light pole bases shall be provided at the sole cost of Developer or Contractor, with the authorization of the City.
7. Conduit shall be installed with 30" of cover.
8. Contact Oakley Beacon Manufacturer Representative
(530) 888-8686.

NOT TO SCALE

APPROVED BY	DATE		STREET LIGHT DECORATIVE DOUBLE L.E.D.	STD. PLAN NO.
 CITY ENGINEER	JUNE 2016 Rev. 5/8/17			E-03

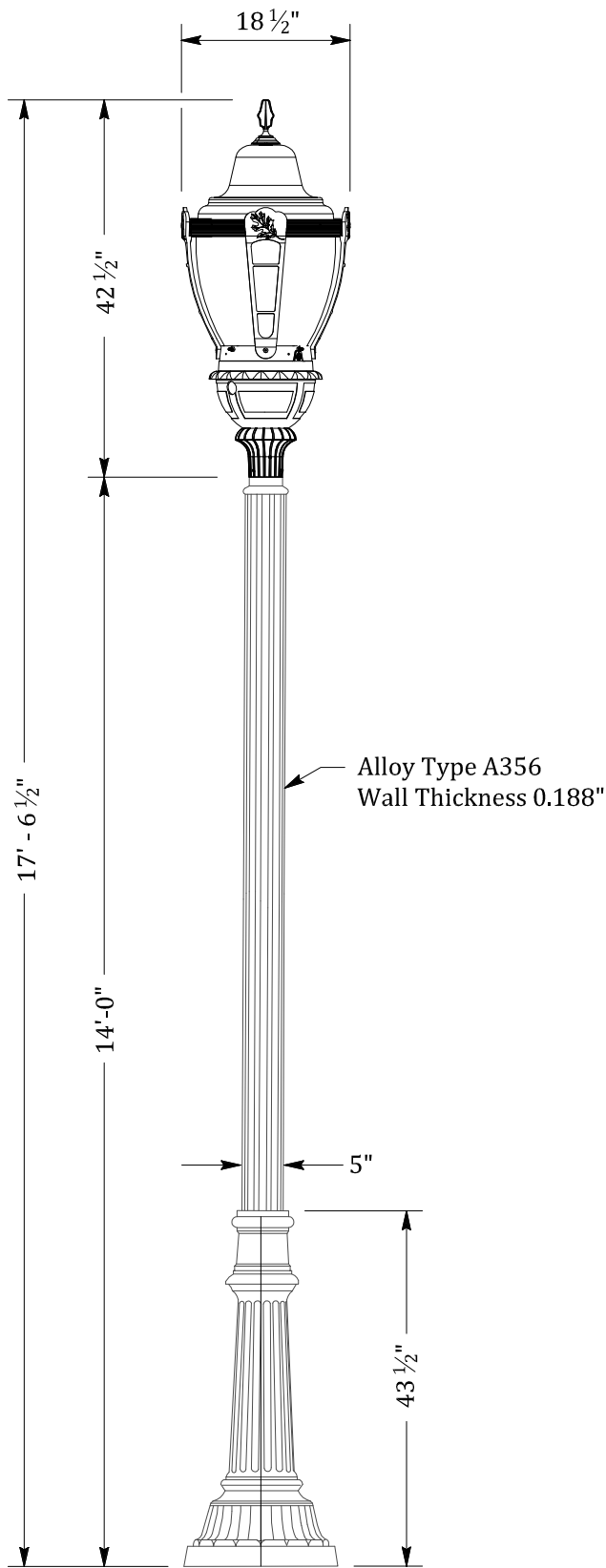

ELEVATION

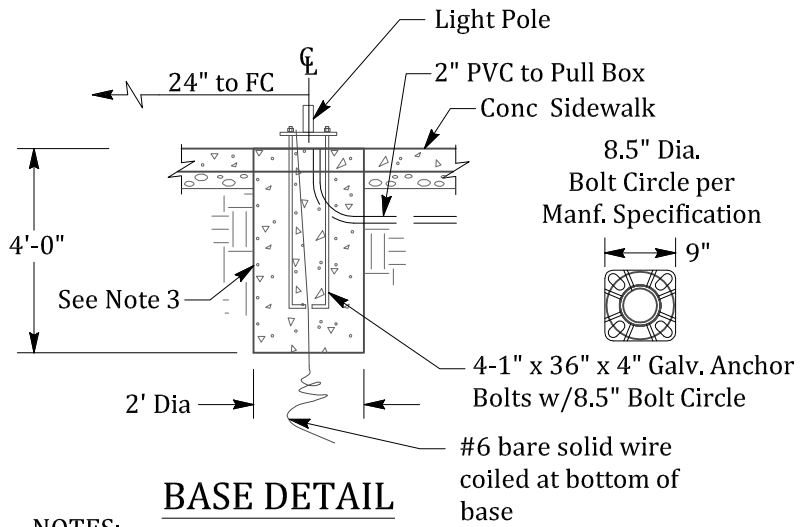

BASE DETAIL

NOTES:

1. Pole Specifications:
 BEACON Pole Model No. RSA-B-SHO-F-14-50-B-OT-BBT + VINY/5/BBT w/clam shell base

 Pole shall be factory prime coated and electrostatically powdered coated "Black" with the allocation of a 3.5-mil weather resistant powder coat whose base is polyester and thermocured. Base painted both inside and out.
2. Fixture Specifications:
 BEACON
 Model No. T1/AF/C3 MOD/H2/24NB-55/4K/UNV/DIR3 or DIR4/PCR-TL-7P/BBT

 Lens: Acrylic, Frosted
 Optics: Type III (residential street)
 Type IV (cul de sac)

 Light: 24 LED Engine and Drivers Combination
 Voltage: 120 Through 277 Volts, 60Hz

 Fixture shall be NRTL Listed for Wet Location.
 Fasteners shall be stainless steel and meet AAMA 605.2 performance specification
3. Foundation Specifications:
 Class "A" Concrete Field Cast 2,500 PSI minimum @ 28 Days.
4. Verify anchor bolt design and bolt circle with manufacturer.
5. Design foundation for 100 mph wind loading.
6. Decorative light pole bases shall be provided at the sole cost of Developer or Contractor, with the authorization of the City.
7. Conduit shall be installed with 30" of cover.
8. Contact Oakley Beacon Manufacturer Representative (530) 888-8686

NOT TO SCALE

APPROVED BY	DATE		STREET LIGHT DECORATIVE SINGLE L.E.D.	STD. PLAN NO.
 CITY ENGINEER	JUNE 2016 Rev. 5/8/17			E-04

TRAFFIC SIGNAL SPECIFICATIONS

ITEM	MANUFACTURER/MODEL OR TYPE (OR APPROVED EQUAL)
SIGNAL CONTROLLER	TYPE 2070
SIGNAL CONTROLLER SOFTWARE	McCAIN OMNI EX INTERSECTION CONTROL SOFTWARE FOR ATC CONTROLLERS VERSION 1.6
VIDEO DETECTION	ITERIS MODEL VANTAGE VECTOR HYBRID VIDEO/RADAR DETECTION SYSTEM. THE VIDEO/RADAR PROCESSORS SHALL BE ITERIS MODEL VANTAGE EDGE 2 PROCESSORS (VEC-EDG201N-PAK)
TRAFFIC SIGNAL CONTROLLER CABINET	McCAIN TYPE 332
PEDESTRIAN COUNTDOWN CLOCK	LEOTEK, MODEL: TSL-PED-16-CIL
PEDESTRIAN PUSH BUTTON	CAMPBELL COMPANY, MODEL: 4EVR
LIGHTED STREET NAME SIGN	SOUTHERN MANUFACTURING, MODEL: CLEAN PROFILE L.E.D. ILLUMINATED SIGN

NOTES:

1. Within 14 calendar days of receipt of Contractor's Materials List, the City shall have the right to request a sample of any materials used for the construction of the traffic signal, or the fiber optic system; including, but not limited to, controller & controller cabinet, and any other item deemed necessary to be tested or inspected for compliance to the specifications. Contractor shall deliver those materials requested within 21 calendar days of request. If the requested materials are not received by the City within the time specified, those materials requested shall be deemed to be unsatisfactory, and rejected.
2. All equipment and software installed shall also be compatible with existing City traffic control system.
3. The Contractor shall arrange to have a signal technician, qualified to work on the controller unit and employed by the controller unit manufacturer or his representative, present at the time the equipment is turned on. The Contractor shall deliver a fully operating system.
4. The Contractor shall furnish a "Certificate of Compliance" assuring the City that the traffic signal controller and cabinet comply with these Special Provisions and that they will operate as shown on the Plans.
5. The maintenance and repair agreement period for furnished equipment shall not commence until the controllers, cabinets, and auxiliary equipment have been installed at the project sites, placed in operation by a factory representative, and the project accepted as complete.

APPROVED BY	DATE		SIGNAL SPECIFICATIONS	STD. PLAN NO.
	JUNE 2016			E-05
CITY ENGINEER				

ALL DIMENSIONS ARE IN INCHES

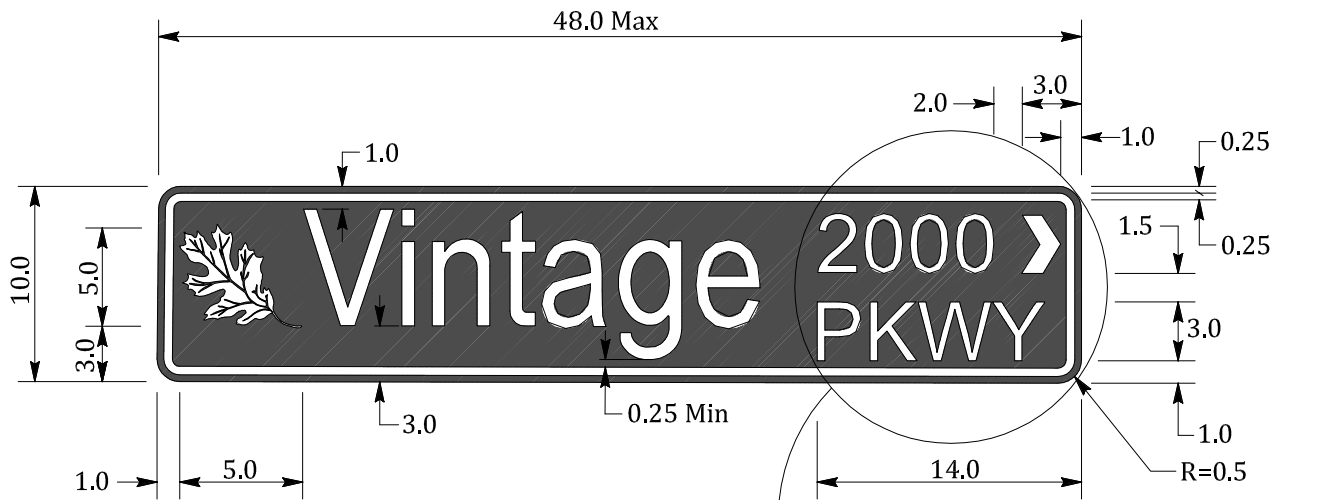

DETAIL

ACCEPTABLE SIGN ABBREVIATION

AVE	Avenue	PL	Place
BLVD	Boulevard	RD	Road
CIR	Circle	ST	Street
CT	Court	TER	Terrace
DR	Drive	PKWY	Parkway
LN	Lane	PVT	Private

REVERSE SIDE

NOTES:

1. A combination of 6" "Highway Gothic" Font (UC) with 4.5" "Highway Gothic" Font (LC) shall be used for street name.
2. Supplementary lettering to indicate the type of street (such as Street, Avenue, or Road) shall be in smaller lettering 3" high.
3. The border shall be 0.5-inch in width. The corners of the sign should be rounded to fit the border.
4. Street name sign blanks shall be 0.125 inch thick, ASTM B209 Alloy 6061-T6, flat aluminum.
5. Reflective sheeting shall be 3M Visual Impact Performance - Series 3990 (green and white) and shall be coated with 3M Premium Protective Overlay Film - Series 1160 (both sides), or approved equivalents.
6. Sign colors shall be a green background with white letters and white border.
7. Signs shall be double faced (front and rear) with block arrows pointing in same direction (ie front to right and rear to left).
8. Sign location and mounting shall be as shown on location detail (SS-03) Sheet 3.

NOT TO SCALE

APPROVED BY	DATE		STREET NAME SIGN MAJOR STREET	STD. PLAN NO.
 CITY ENGINEER	JUNE 2016			SS-01

ALL DIMENSIONS ARE IN INCHES

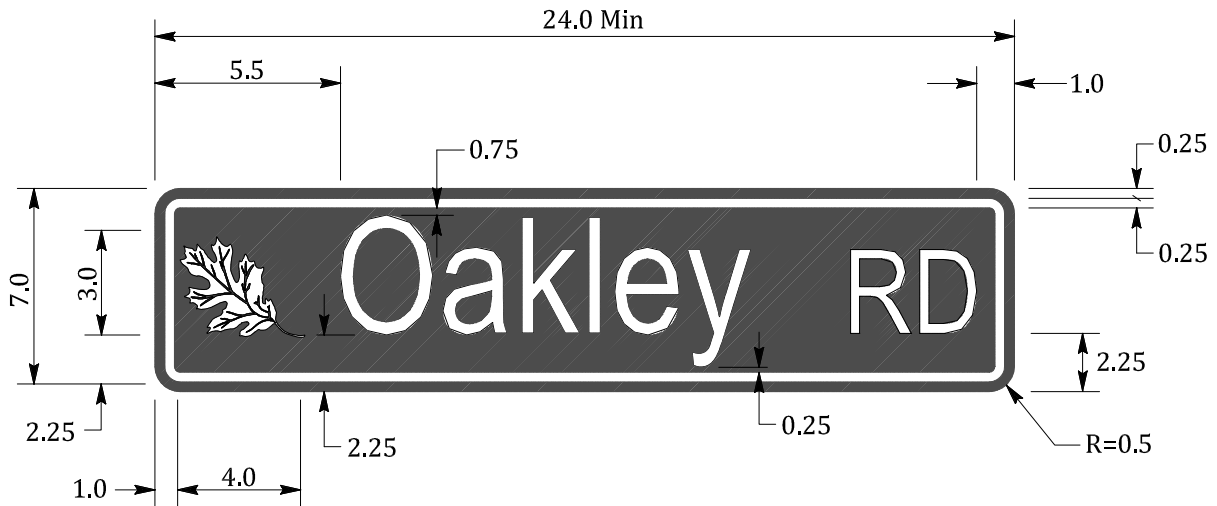

DETAIL

ACCEPTABLE SIGN ABBREVIATION

AVE	Avenue	PL	Place
BLVD	Boulevard	RD	Road
CIR	Circle	ST	Street
CT	Court	TER	Terrace
DR	Drive	PKWY	Parkway
LN	Lane	PVT	Private

NOTES:

1. A combination of 4" "Highway Gothic" Font (UC) with 3" "Highway Gothic" Font (LC) shall be used on low-volume roads and on urban street with speeds of 25 MPH.
2. Supplementary lettering to indicate the type of street (such as Street, Avenue, or Road) shall be in smaller lettering 3" high.
3. The border shall be 0.25-inch in width. The corners of the sign should be rounded to fit the border.
4. Street name sign blanks shall be 0.125 inch thick, ASTM B209 Alloy 6061-T6, flat aluminum.
5. Reflective sheeting shall be 3M Visual Impact Performance - Series 3990 (green and white) and shall be coated with 3M Premium Protective Overlay Film - Series 1160 (both sides), or approved equivalents.
6. Sign colors shall be a green background with white letters and white border.
7. Signs shall be double faced (front and rear)
8. Sign location and mounting shall be as shown on location detail (SS-03) Sheet 3.
9. At the intersection with public street/private street name sign shall match the Standard Drawings but must have "PVT" where the block would go.

NOT TO SCALE

APPROVED BY	DATE		STREET NAME SIGN MINOR STREET	STD. PLAN NO.
 CITY ENGINEER	JUNE 2016			SS-02

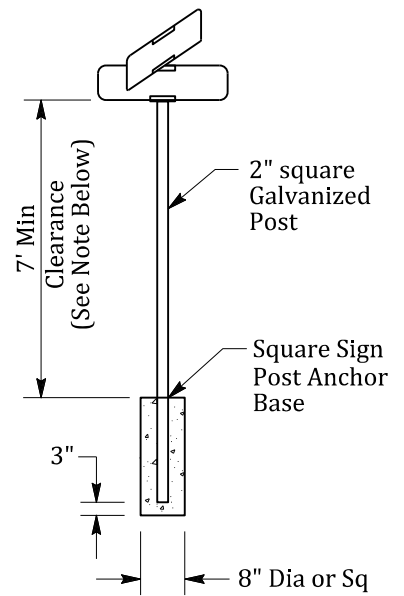
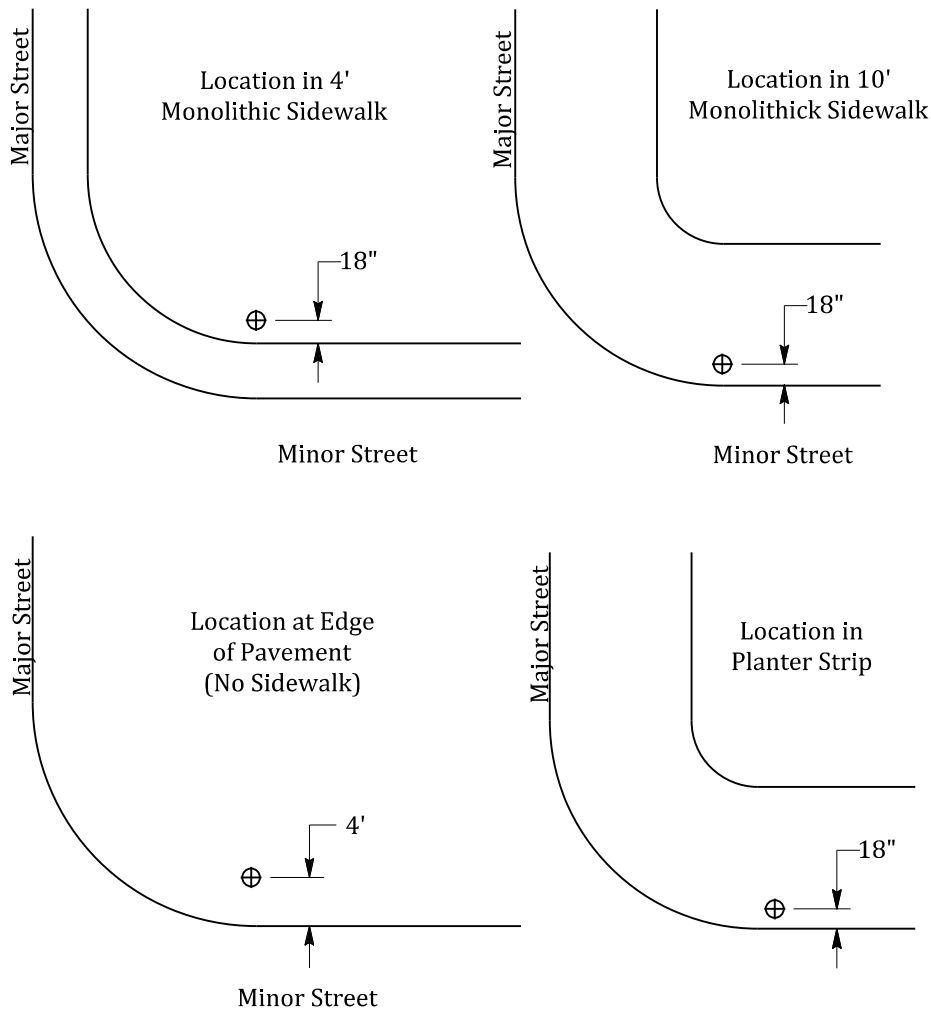

DETAIL "A"
(Typical)

NOTE:
Stop signs mounted on same post as street name signs shall be below street name signs. (See Note 6)

SIGN LOCATIONS

NOTES:

1. Sign to be located 18 inches from face of curb or back of 4' monolithic sidewalk.
2. Bottom of sign shall be mounted 7 feet Min above ground or sidewalk per Detail "A" shown on this sheet.
3. Signs to be City of Oakley Standard Street Name Sign.
4. Signs shall be mounted with Hawkins' Heavy Duty Aluminum "Vandal Proof" (HD) VP Model #V14F-(HD)VP-2C2P (without finial) or approved equal.
5. Signs mounted on signal standards or electroliers shall be mounted with Hawkins' "Vandal Proof" wing bracket Model #V14F-(HD) VP-AB or approved equal. Brackets shall be fastened to poles with two (2) 3/4" wide x 0.030" thick Type 201 Stainless Steel bends.
6. Street name sign may be combined with stop sign (R1), and placed in a location for maximum visibility as approved by the City Engineer.

NOT TO SCALE

APPROVED BY	DATE		STREET NAME SIGN LOCATION AND MOUNTING	STD. PLAN NO.
 CITY ENGINEER	JUNE 2016			SS-03

List of trees below are suitable for use in the residential public easement areas in Oakley. Care in selecting the proper tree for the specified need should be foremost in the decision - recommendation process. Small Accent trees can be planted in the easement area but do not meet the criteria of a "Street Tree". Standard trees only. No multi-trunk. The Parks and Landscape Division shall have final decision-making authority on all trees approved in public landscape areas.

SMALL ACCENT TREES (Under 25' high)

TREE NAME	VARIETY	COMMON NAME	COMMENTS
Arbutus	Marina	Hybrid Strawberry Madrone	Fruit can be messy
Cercidphyllum Japonicum		Katura Tree	
Cercidium Hybrid	Desert Museum	Palo Verde	
Cercis Canadensis		Eastern Redbud	Male only
Chionanthus Retusus		Chinese Fringe Tree	Susceptible to aphids
Chitalpa Tashkentensis	Pink Dawn or Morning Cloud		Poisonous berries
Crataegus Phaenopyrum		Washington Hawthorn	
Geijera Parviflora		Australian Willow	
Lagerstroemia Indica		Hybrid Crape Myrtle	
Laurus Nobilis	Saratoga	Grecian Laurel - Sweet Bay	
Magnolia Grandiflora	Little Gem, Magnolia Virginiana or Jim Wilson Moonglow	Magnolia	
Prunus Crasifera	Krauter Vesuvius	Purple-Leaf Plum	Fruit can be messy
Vitex Agnus-Castus		Chaste	

"STREET TREES" - Medium sized (25' to 45' high)

TREE NAME	VARIETY	COMMON NAME	COMMENTS
Acer buergerianum		Trident Maple	
Acer truncatum	Pacific Sunset or Norwegian Sunset	Shantung Maple	
Amelanchier Laevis		Spring Flurry Serviceberry	
Carpinus Caroliniana		American Hornbeam	Insects, other issues?
Ginkgo biloba	Fairmont, Autumn Gold or Princeton Sentry	Maidenhair	Male - Sterile Only
Koelreuteria bipinnata		Chinese Flame Tree	
Maackia Amurensis	Maackia	Magnolia	
Magnolia grandiflora	St. Mary	MaacNificent	
Magnolia soulangeana		Saucer Magnolia	
Metrosideros excelsus		New Zealand Christmas Tree	Large Root Area
Nyssa sylvatica		Sour Gum - Tupelo	
Ostrya Virginiana		American HopHornbeam	
Pistacia chinensis	Pearl Street, Red Push or Keith Davey	Chinese Pistacia	Male Only
Pyrus calleryana	Chanticleer, New Bradford	Flowering Pear	
Tilia cordata	Greenspire, Shamrock or Redmond	Little Leaf Linden	Susceptible to Aphids
Tristaniopsis laurina	Elegant	Tristania Water Gum	Susceptible to Aphids
Tristania confertax	Lophostemon	Brisbane Box	Susceptible to Aphids
Ulmus parvifolia	Emerald Flair Elm	Chinese Elm	Potential Anthracnose issue
Ulmus Propinqua	Emerald Sunshine Elm	Sunshine Elm	
Ulmus Wilsoniana	Prospector	Prospector Elm	

LARGE TREES (Over 45' high) - NOT FOR RESIDENTIAL

TREE NAME	VARIETY	COMMON NAME
Acer rubrum	Red Sunset or October Glory	Red Maple
Cedrus Atlantica	Glauca	Blue Atlas Cedar
Celtis Australis		European Hackberry
Magnolia grandiflora	Edith Bogue	Magnolia
Metasequoia glyptostroboides		Dawn Redwood
Pinus Eldarica		Afghan Pine
Plantinus a.	Morton Circle	Exclamation Planetree
Quercus Agrifolia		Coast Live Oak
Quercus ilex		Holly Oak
Quercus Rubra		Red Oak
Quercus virginiana		Southern Live Oak
Zelkova serrata	Village Green or Musashimo columnar	Sawleaf Zelkova

Note: The list above is restricted as the City prohibits the planting of trees in the public easement area with fruit, undesirable seeds, cones, or nuts; Trees with voracious shallow root systems that are known to cause sidewalk or driveway damage; and trees with known pest (disease, insect or invertebrate) problems.

APPROVED BY	DATE		PREFERRED TREE LIST	STD. PLAN NO.
 CITY ENGINEER	JUNE 2016			L-01

TREE SPECIFICATIONS

All trees must meet the following minimum specifications:

1. HEIGHT: 7 - 8 feet high planted in the ground.
2. CALIPER: 1 ½ inches, measured 6 inches from the base (24 inch Box Minimum).
3. BRANCHING NEED: Minimum spread of 2 - 3 feet with good branch distribution
4. CENTRAL LEADER: Single, relatively straight

Any exception to the above must be approved by the City.

All planting stock must have the approval of the City.

City reserves the right to reject trees that do not meet high quality nursery stock of the current edition of the Guideline Specifications for Nursery Tree Quality, published by the Urban Tree Foundation

PLANTING SEQUENCE

1. Dig the planting hole as deep as the container and twice as large as its diameter
2. Remove the root ball carefully from the container by supporting it from below. Sever any circling roots ($\frac{3}{16}$ inch or greater) with sharp shears or knife. If the root ball is dense or compacted, carefully loosen the roots at the side and bottom of the root ball. Do not pull the root ball apart. The severing of large roots will encourage new roots initiating at the cuts.
3. Center root ball in hole on undisturbed soil such that root crown is visible at the top of the root ball and 2 inches above grade.
4. Fill planting hole around root ball with backfill mix and foot-tamp in lifts. Be careful not to disturb the root ball.
5. Backfill mix shall include U.C. Ag. mix or approved equivalent. U.C. Ag. mix shall be combined with p existing soil, $\frac{1}{3}$ mix, $\frac{2}{3}$ native soil unless specified otherwise by the soils analysis.
6. Fertilizer and post-plant fertilizer shall be as required by soils analysis.
7. Use the remaining native soil to create a basin appropriate to the site.

APPROVED BY	DATE		TREE PLANTING SPECIFICATIONS	STD. PLAN NO.
 CITY ENGINEER	JUNE 2016			L-02

NOTES:

1. Avoid damage to roots.
2. Avoid root ball when placing stakes.
3. Root barrier required for trees 6' or less from paving. Installed against paving per mfrs. specifications for a linear installation. Panel length per mfrs. specifications and extend a min. length of 10' from trunk.
4. Backfill mix and pst-plant fertilizer as required by soils analysis.

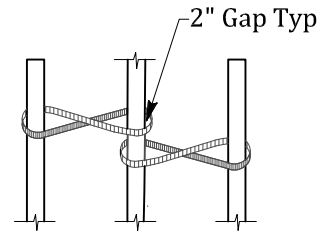

DETAIL A

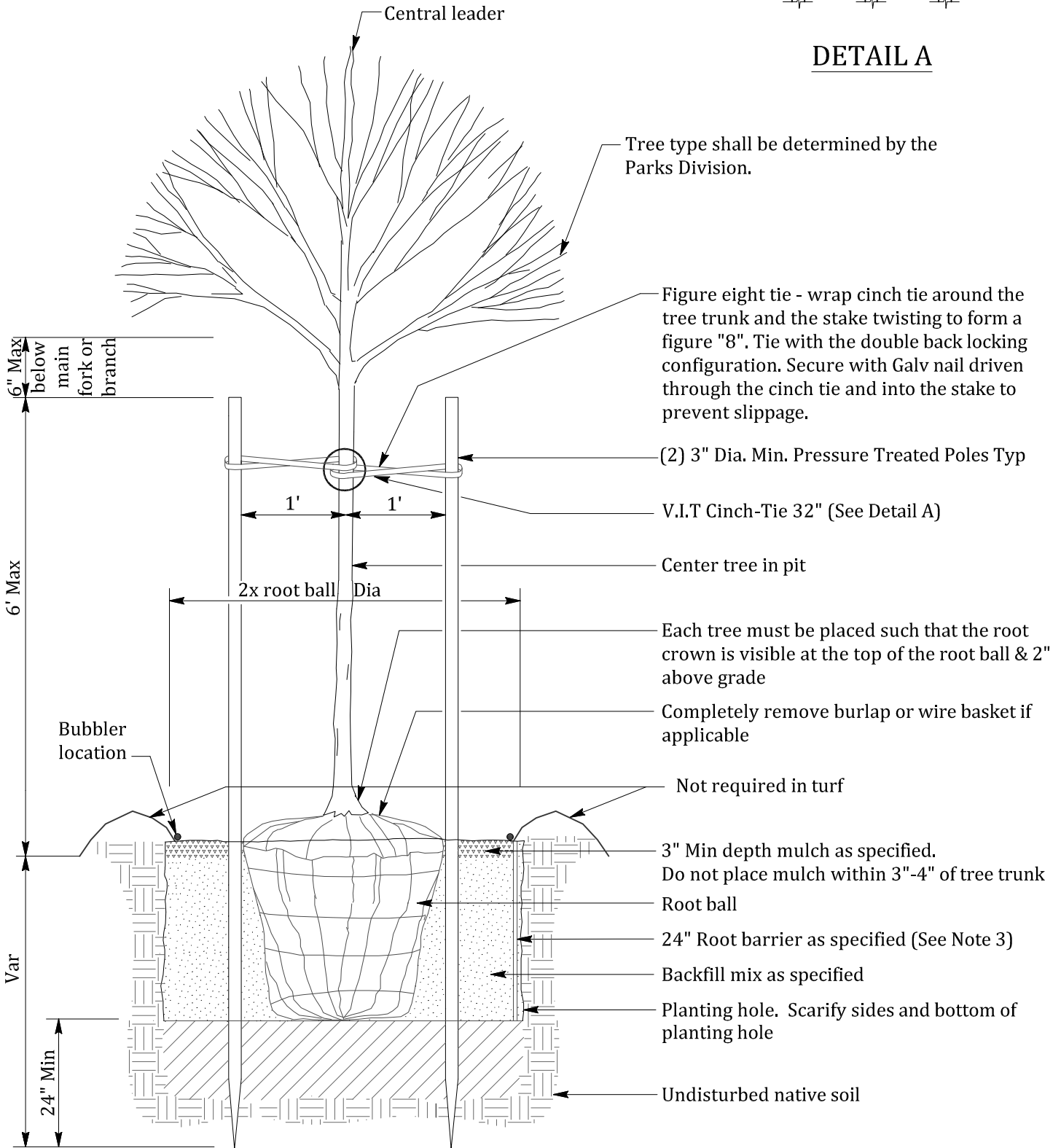

NOT TO SCALE

APPROVED BY	DATE		TREE PLANTING	STD. PLAN NO.
<i>Kevin Rohan</i>	JUNE 2016			L-03
CITY ENGINEER				

NOTES:

1. Backfill mix and post-plant fertilizer as required by soils analysis.

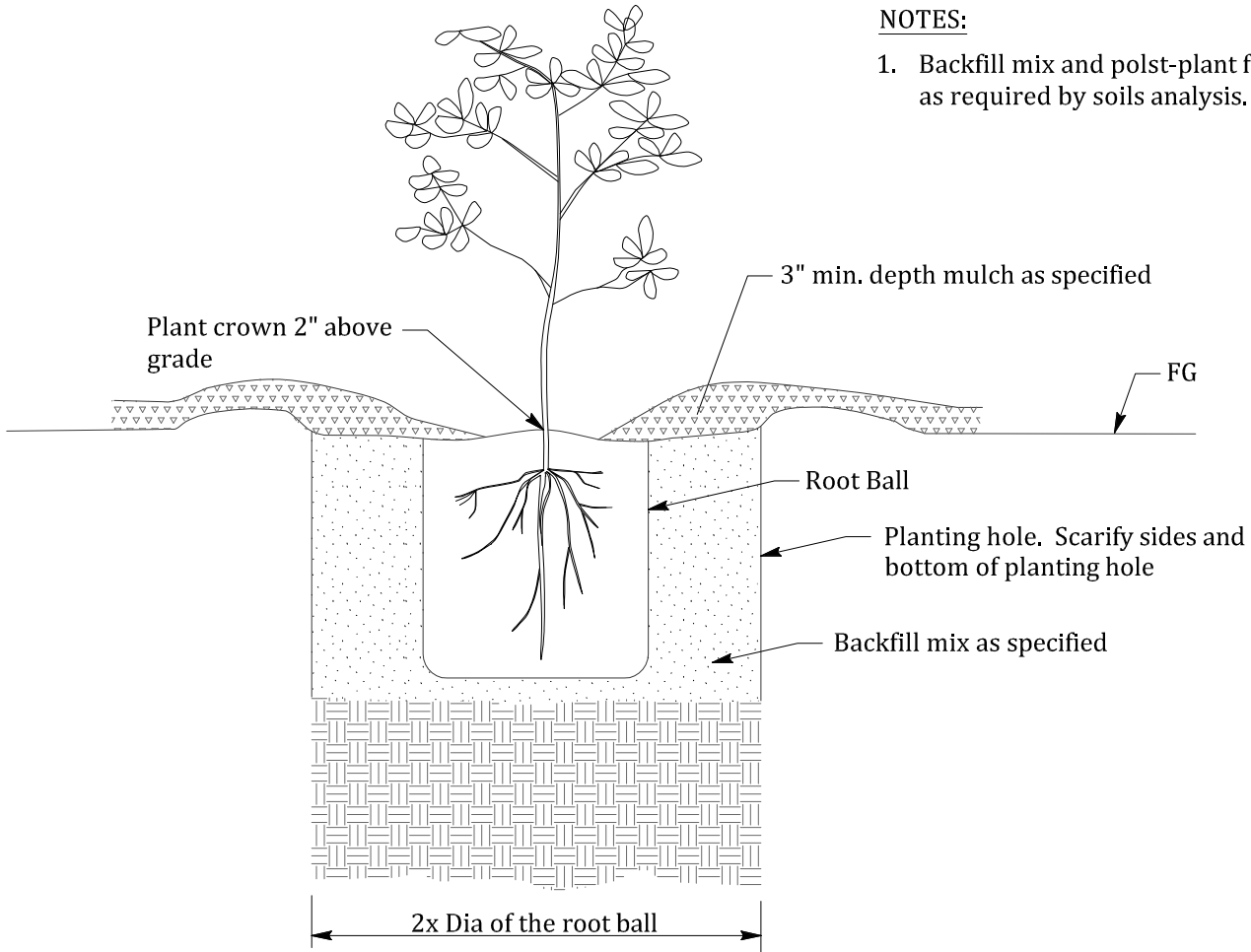

SHRUB PLANTING DETAIL

NOT TO SCALE

APPROVED BY	DATE		SHRUB PLANTING	STD. PLAN NO.
 CITY ENGINEER	JUNE 2016			L-04

IRRIGATION EQUIPMENT LIST

ITEM	MANUFACTURER/MODEL (OR APPROVED EQUAL)
Backflow Preventer	Per Diablo Water District Specifications and Details
Gate Valve (3 inch and larger)	Nibco 619 RW-SON
Gate Valve (2 ½ inch and smaller)	Nibco T113-K
Ball Valve	Nibco T-FP-600a Full Port Brass or KBI SCH 80 PVC True Union Type
Quick Coupling Valve	44 IRC or 44 NP (for Non-Potable)
Pressure Reducing Valve	Wilkins 500HLR Series
Master Valve	Included with Controller Assembly (See Note 1 below)
Flow Sensor	Included with Controller Assembly (See Note 1 below)
Remote Control Valve	Rainbird PESB or PESB-R (for non-potable), PRS-D Pressure Regulator option
Valve Boxes with Stainless Steel Lock-Down Bolts	Carson Trusst black colored box and lid for t- cover planters, green colored box and t-cover for turf areas. Carson Specification Grade.
Gate & Quick Coupling Valve Box with Stainless Steel Lock-Down Bolts	Carson Trusst Round black colored box and t- cover lid for planters, green colored box and t-cover lid for turf areas. Carson Specification Grade.
Controller Assembly	Rain Master Evolution DX II with SiteOne Satellite Assembly (See Note 1 Below)
Backflow Enclosure	Per Diablo Water District Specifications and Details
Backflow Preventer Freeze Protection	Per Diablo Water District Specifications and Details
Pop-Up Stream Rotor	Rainbird 1800 Series (PRS-SAM) with Hunter MP Rotator Nozzles
Gear Driven Rotor	Rainbird 5000 Series Hunter PGP
Pop-Up Spray	Rainbird 1800 Series (SAM-PRS)
Bubbler	Rainbird 1400 Series
Tree Bubbler	Rainbird RWS-B Series
Sub-Surface Irrigation	Rainbird XFS

NOTES:

1. SiteOne Satellite assembly with SA6-RM4-XX/FAN-16/RHG/RDM/PMR/FSAVC-XXX/RSE-DX/GRP-K/EV-CAB-SEN/
EV-CAB-COM (if hardwiring DX2 controller together), Pro Max receiver, 1 Pro Max transmitter for every 5 assemblies,
enclosure fan, housed in a top entry stainless steel enclosure, flow sensing assembly, with master valve, sensor cable, and
rain sensor. Contact SiteOne Representative at (800)-SITE ONE for purchase order, pre-construction meeting, test for
clear reception for radio communication with central computer, warranty, and certification. Contractor to verify power
availability and install unit per manufacturers specifications on specified concrete pad.
2. All planters should be designed with a 100% bubbler based system (no drip or micro irrigation). Pop-Up rotators will
be allowed in some instances (ground cover), but only on 5' or wider planters. Rotors are preferred for all turf areas.
Where rotors are not feasible, pop-up rotators will be accepted as a substitute.

APPROVED BY	DATE		IRRIGATION EQUIPMENT LIST	STD. PLAN NO.
	JUNE 2016			IR-01
CITY ENGINEER				

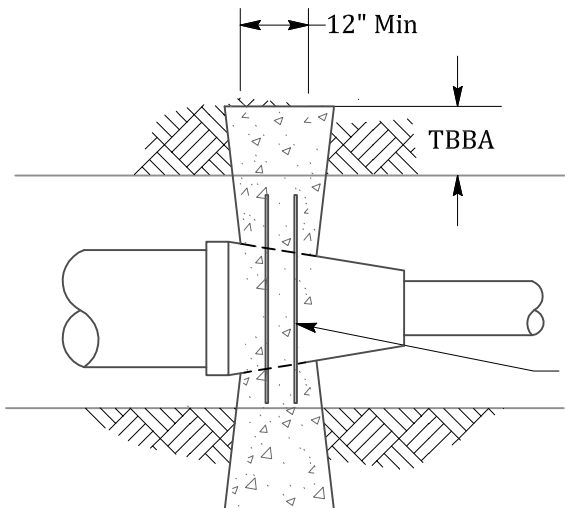

REDUCERS

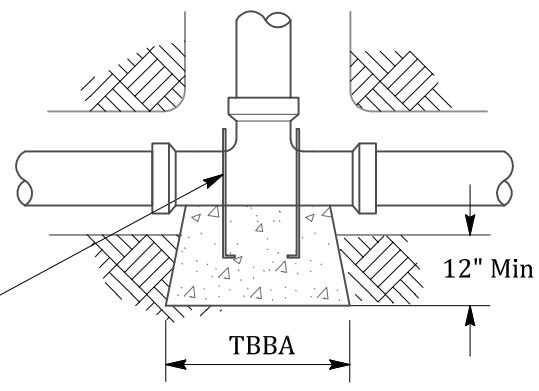

TEES & DEAD ENDS

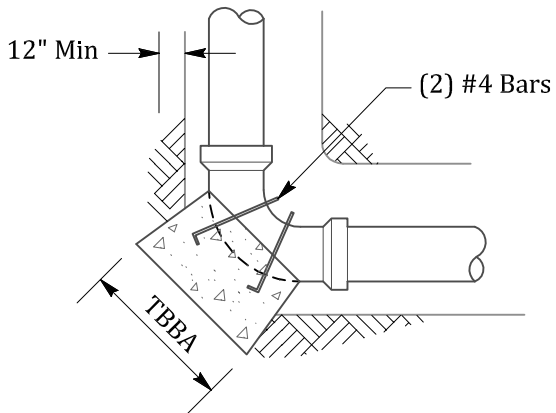

ELBOWS

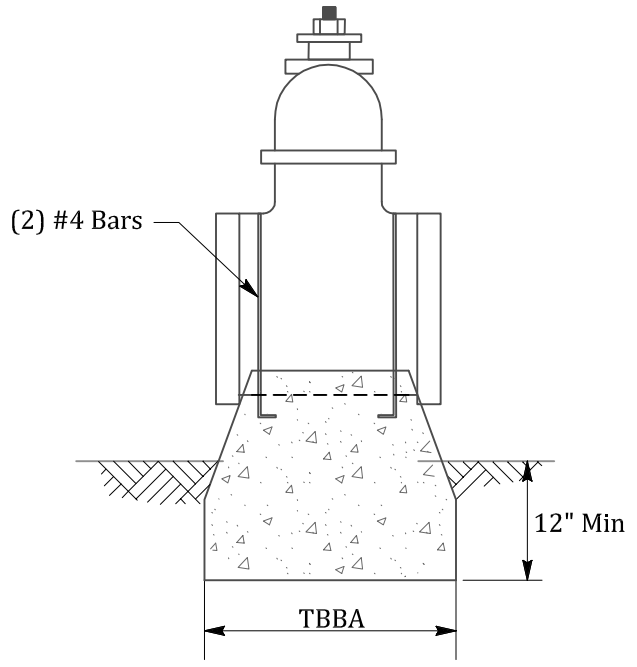

VALVES

NOTES:

1. Thrust blocks shall not project higher than 1/2 the distance from the bottom of the trench to finish grade. Place concrete against undisturbed soil.
2. Do not cover ends of fittings or bolts with concrete.
3. Concrete shall have compression strength of 2000 PSI.
4. Consult Manufacturer's literature for recommended thrust bearing area (TBBA) based on actual field conditions. At Minimum TBBA shall be sized as follows:

PIPE SIZE	90-DEGREE ELLS	45-DEGREE ELLS	VALVES, TEES, REDUCERS, DEAD ENDS
4"	1.5 SQ FT	1.0 SQ FT	1.0 SQ FT*
6"	3.5 SQ FT	2.5SQ FT	2.5SQ FT*
8"	6.3 SQ FT	4.5 SQ FT	4.5 SQ FT*

* OR AS DESIGNED BY THE ENGINEER.

NOT TO SCALE

APPROVED BY	DATE		IRRIGATION SYSTEM THRUST BLOCKING	STD. PLAN NO.
 CITY ENGINEER	JUNE 2016			IR-02

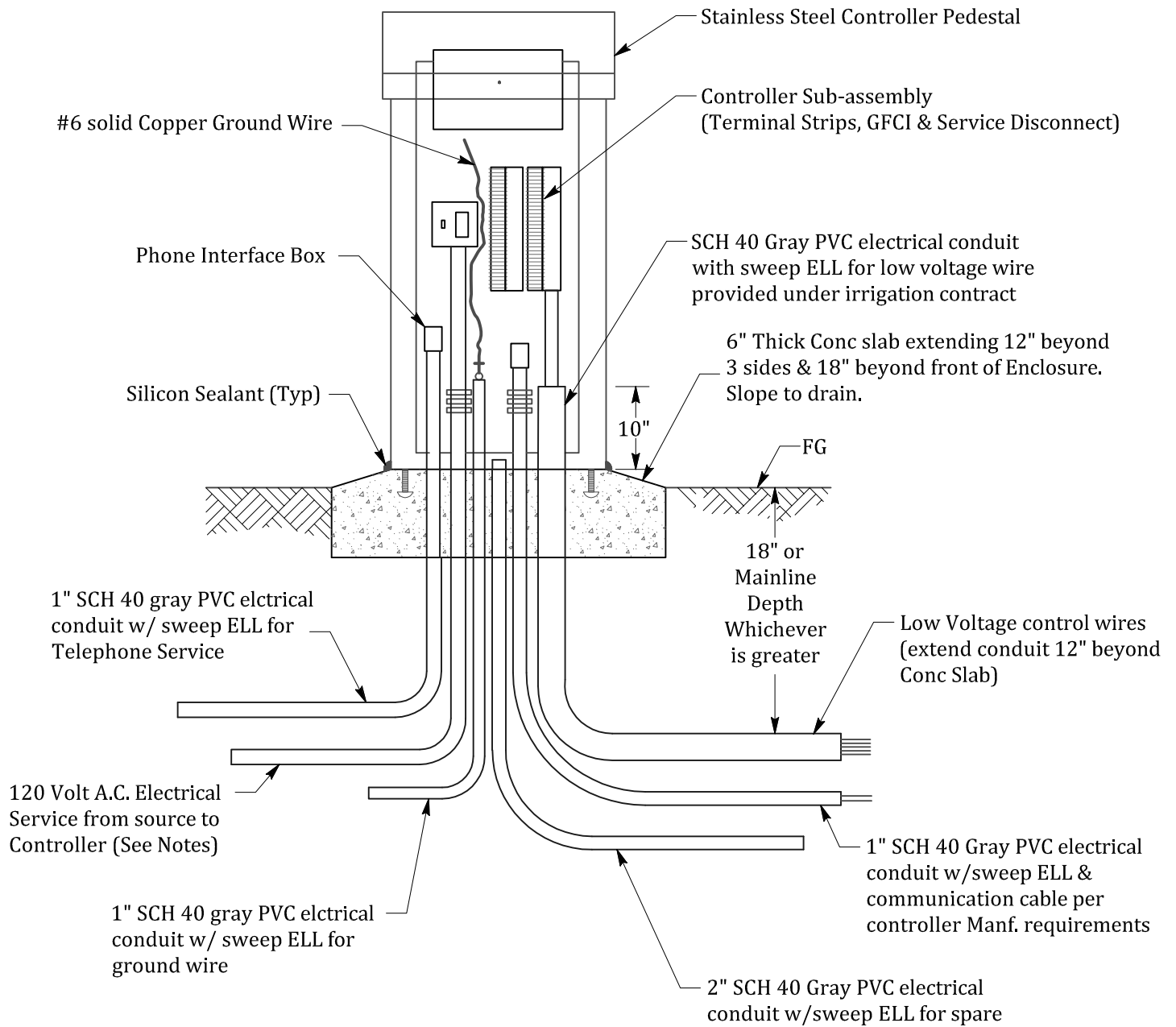

NOTES:

1. Electrical service from source to controller location shall be provided by the Electrical Contractor.
2. Irrigation Contractor shall provide rigid steel conduit from service stub-out to controller GFCI switch and shall complete electrical service to controller.
3. Enclosure's field location and orientation shall be approved by the City.
4. Landscape Designer to determine the need for a High Gain Antenna Installation. If required, landscape plans must show installation details.

NOT TO SCALE

APPROVED BY	DATE		IRRIGATION CONTROLLER	STD. PLAN NO.
 CITY ENGINEER	JUNE 2016			IR-03

SIDE VIEW

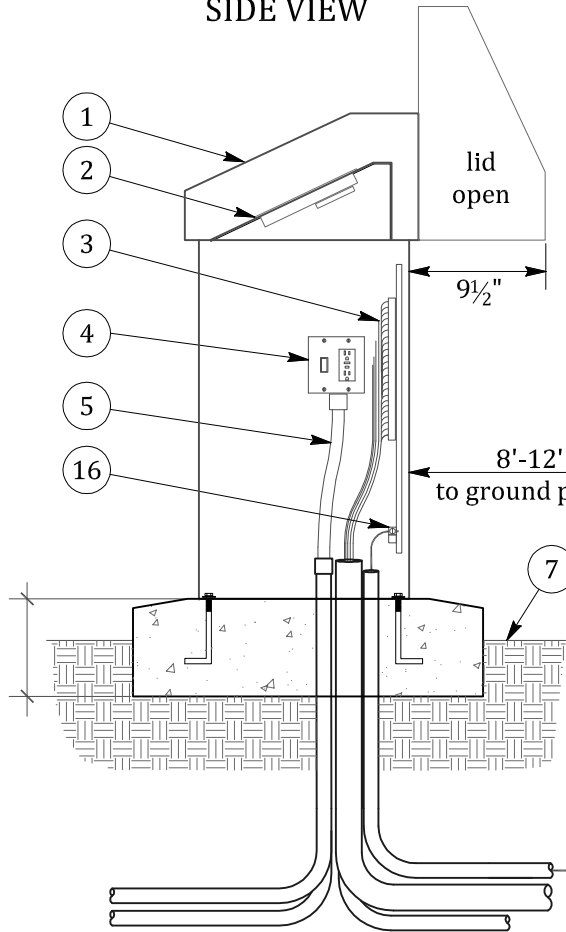

FRONT VIEW

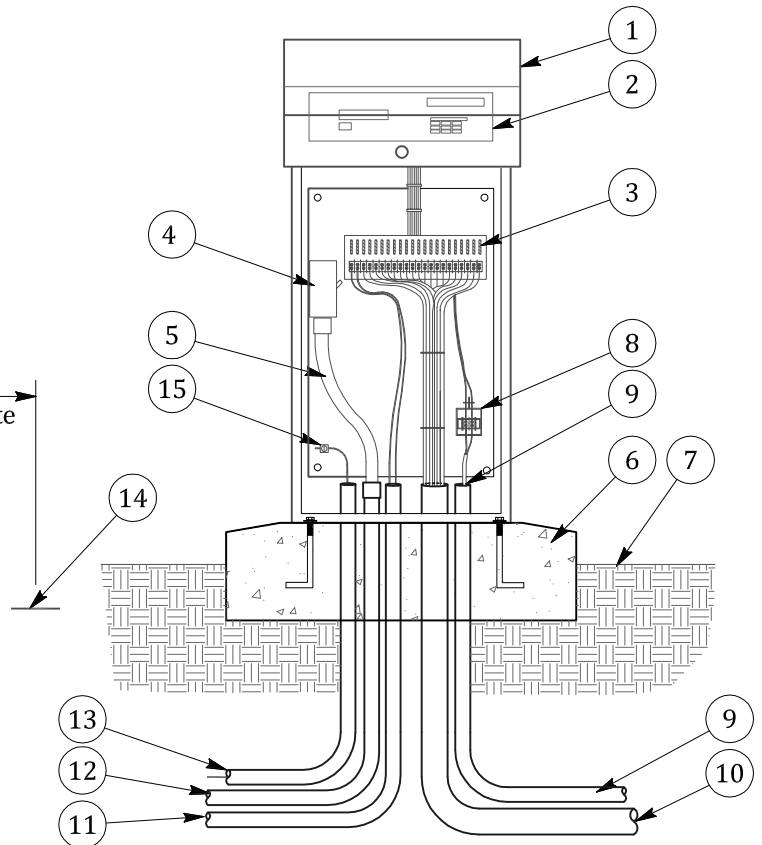

- ① Strongbox Stainless Steel NEMA 3R Rainproof Enclosure (ul listed).
- ② Satellite Assembly. Assembled in enclosure by Siteone GreenTech.
- ③ Terminal strip for valve wires.
- ④ GFCI Receptacle.
- ⑤ Electrical Flex Conduit for power.
- ⑥ 6" Min thick, Concrete Pad with Anchor Bolts per manufacturer recommendations.
- ⑦ Finished grade.
- ⑧ Flow Sensor Terminal Board.
- ⑨ 1" SCH 40 gray PVC electrical conduit w/ sweep ell with Flow Sensor Cable.
- ⑩ 3" SCH 40 gray PVC electrical conduit w/ sweep ell for lead wires.
- ⑪ 1" SCH 40 gray PVC electrical conduit w/ sweep ell for Master Valve wires.
- ⑫ 1" SCH 40 gray PVC electrical conduit w/ sweep ell for 110 vac Power Line.
- ⑬ 1" SCH 40 gray PVC electrical conduit w/ sweep ell for Ground Wire.
- ⑭ Grounding Plate required, See Detail IR-07
- ⑮ #6 Ground Wire secured to Backboard Grounding Terminal.

NOTES:

- 1. See irrigation controller Detail IR-01 for satellite communications components
- 2. Conduit sizes are approximate and may need to be larger for field conditions

NOT TO SCALE

APPROVED BY	DATE		IRRIGATION CONTROLLER ENCLOSURE TOP OPENING	STD. PLAN NO.
 CITY ENGINEER	JUNE 2016			IR-04

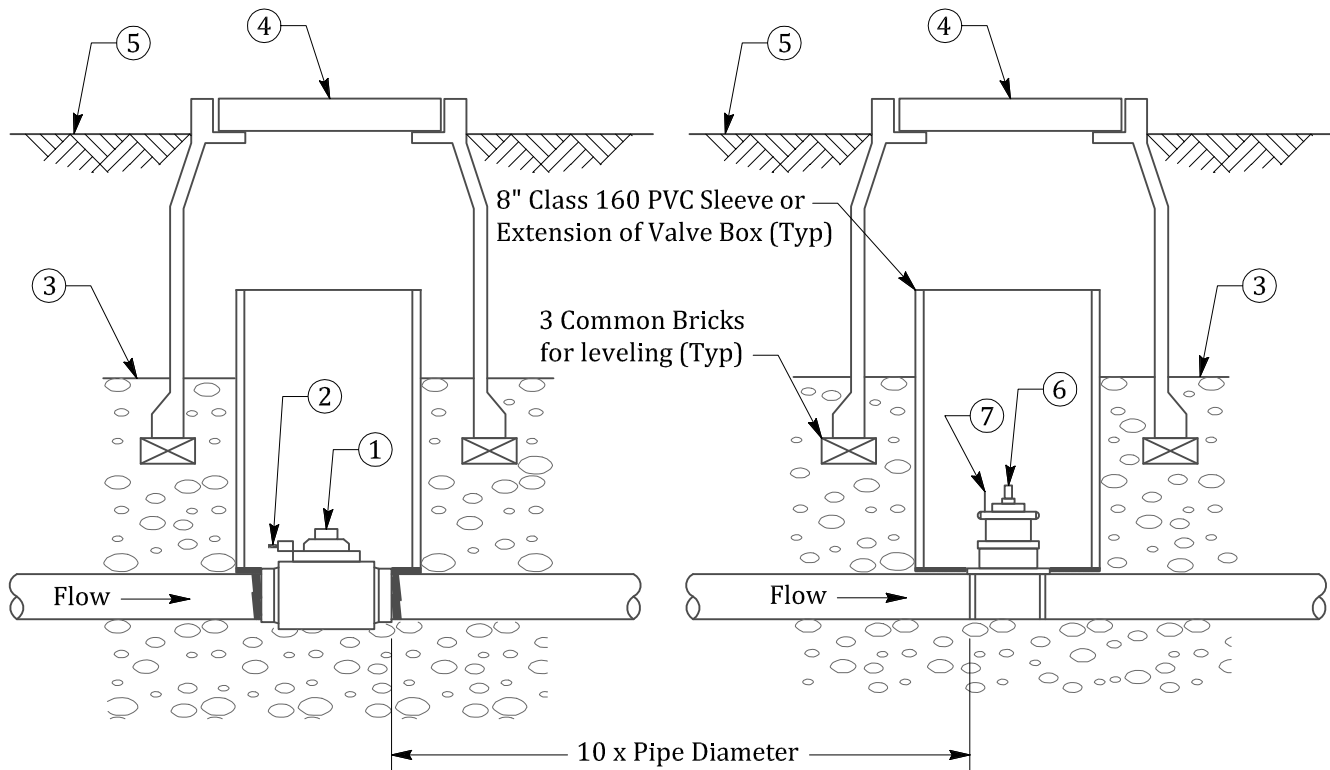

PLAN

LEGEND:

- ① Master Valve(s) (normally closed)
- ② Wire to Controller Assembly (PE-89 Shielded Cable) in 1" SCH 40 gray PVC electrical conduit w/ sweep ELL
- ③ 12" min. Drain Rock. Extend 2" min. beyond perimeter of box
- ④ Rectangular Valve Box and Lid, See Note 2
- ⑤ Finish Grade
- ⑥ Data Industrial IR220 Series Flow Sensor(s)
- ⑦ Wire to flow sensing equipment at controller assembly in 1" SCH 40 gray PVC electrical conduit w/ sweep ELL

NOTE:

1. See Standard Plan IR-06 for Flow Sensor Detail
2. See Standard Plan IR-08 for Irrigation Valve Box Installation

APPROVED BY	DATE		<h2 style="margin: 0;">MASTER VALVE AND FLOW SENSOR</h2>	STD. PLAN NO.
	JUNE 2016			IR-05
CITY ENGINEER				

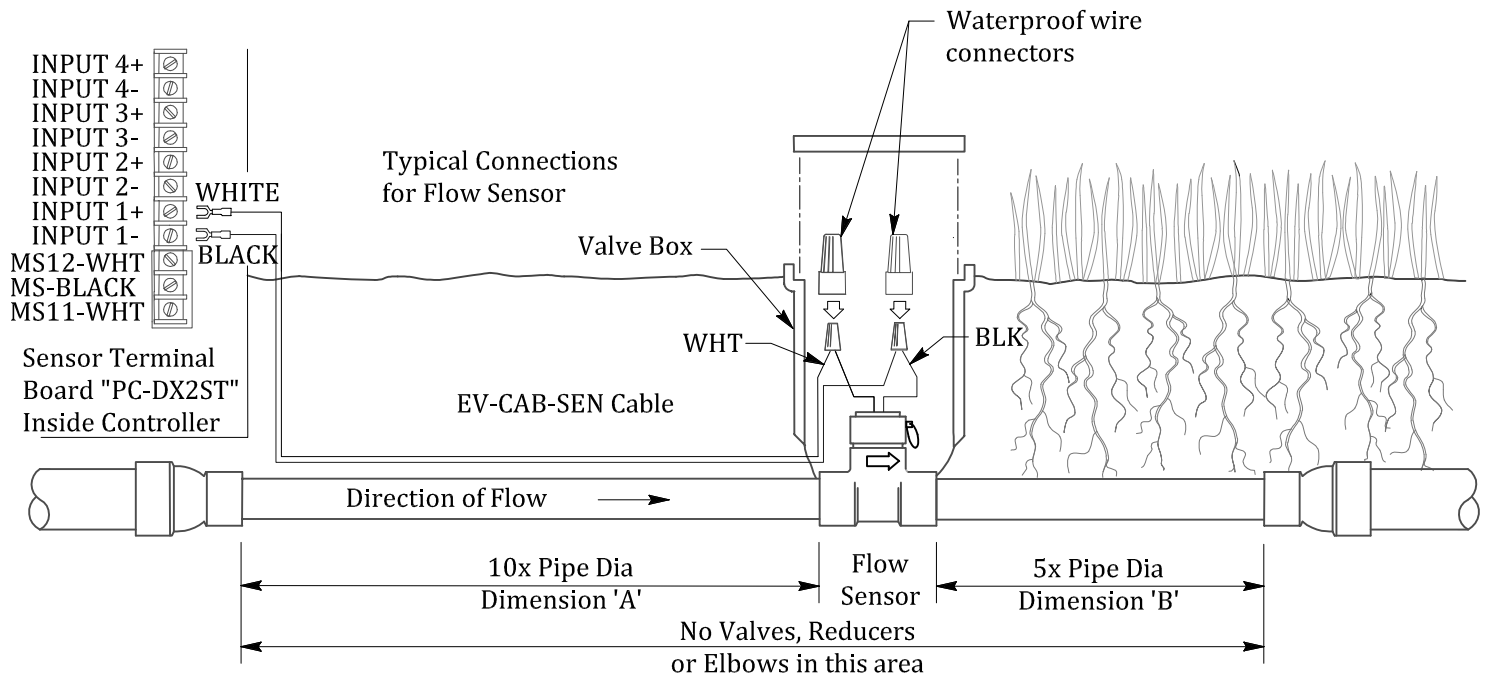

Example: For 3" Flow Sensor, Dimension "A" Minimum 30"
 Dimension "B" Minimum 15"

NOTES:

Upon completion of the physical installation of the flow sensor, complete the wiring connection from the flow sensor to the DX2 Controller by following the procedure below.

1. TURN THE POWER OFF AT THE CONTROLLER.
2. At the Flow Sensor:
 Connect the BLACK wire of the Flow Sensor to the BLACK wire of the "EV-CAB-SEN" sensor cable.
 Connect the WHITE wire of the Flow Sensor to the WHITE wire of the "EV-CAP-SEN" sensor cable.
 *Use the weatherproof connectors provided with the Flow Sensor to make the connection.
3. At the controller:
 Connect the BLACK wire of "EV-CAB-SEN" to "INPUT 1-" of the SENSOR TERMINAL BOARD (PC-DX2ST).
 Connect the WHITE wire of "EV-CAB-SEN" to "INPUT 1-" of the SENSOR TERMINAL BOARD (PC-DX2ST).
4. Turn POWER ON at the Controller.
5. Set the Rain Master "K" and "OFFSET" values for the Flow Sensor at the controller based on the type and size of the Flow Sensor installed.
6. See Standard Plan IR-08 for Irrigation Valve Box Installation

REFER TO THE TABLE PROVIDED WITH THE FLOW SENSOR FOR CORRECT "K" AND "OFFSET" FOR YOUR APPLICATION

NOT TO SCALE

APPROVED BY	DATE		FLOW SENSOR DETAIL	STD. PLAN NO.
 CITY ENGINEER	JUNE 2016			IR-06

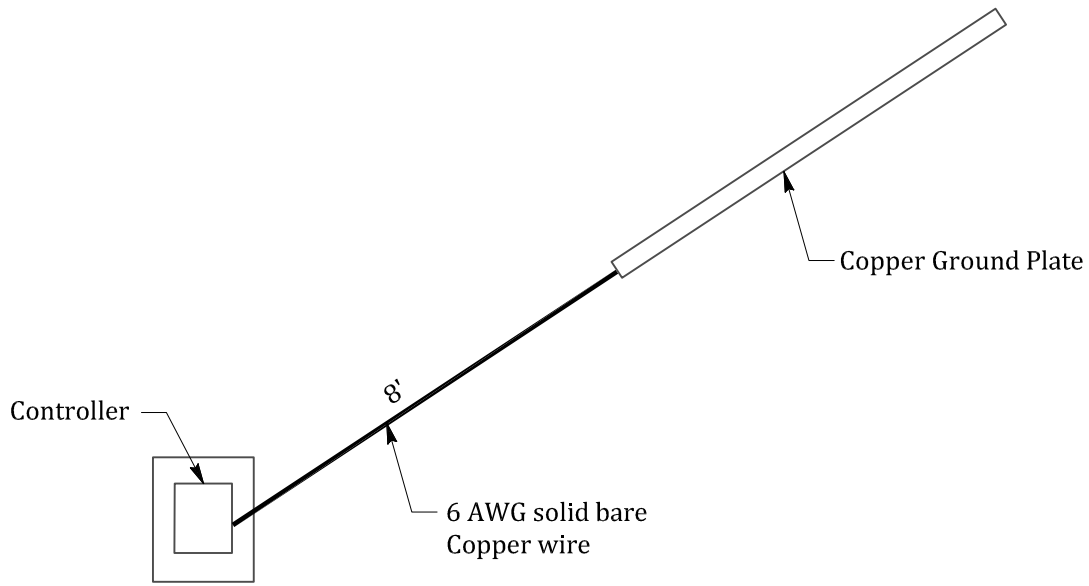

TOP VIEW

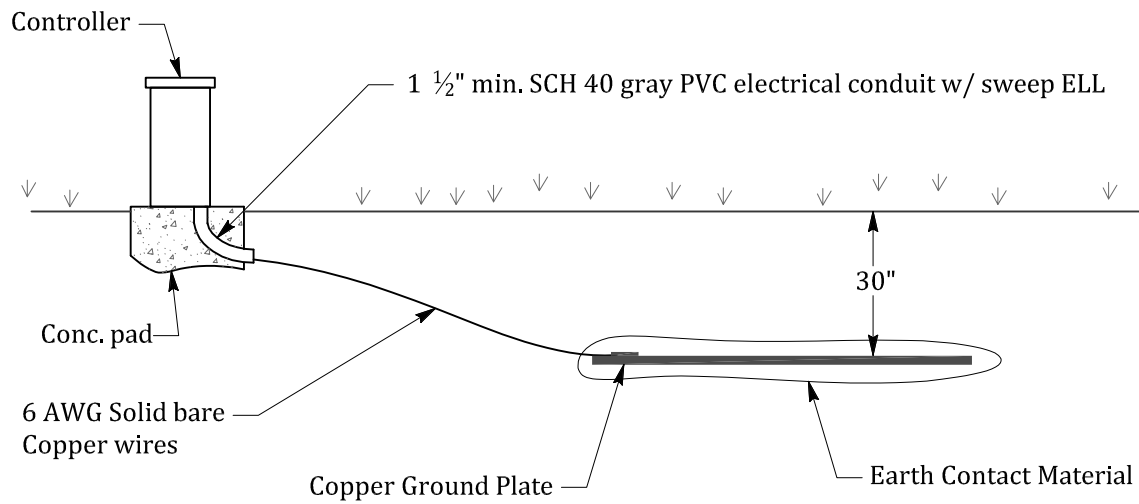

SIDE VIEW

NOT TO SCALE

APPROVED BY	DATE		CCU or FIELD SATELLITE GROUNDING GRID	STD. PLAN NO.
 CITY ENGINEER	JUNE 2016			IR-07

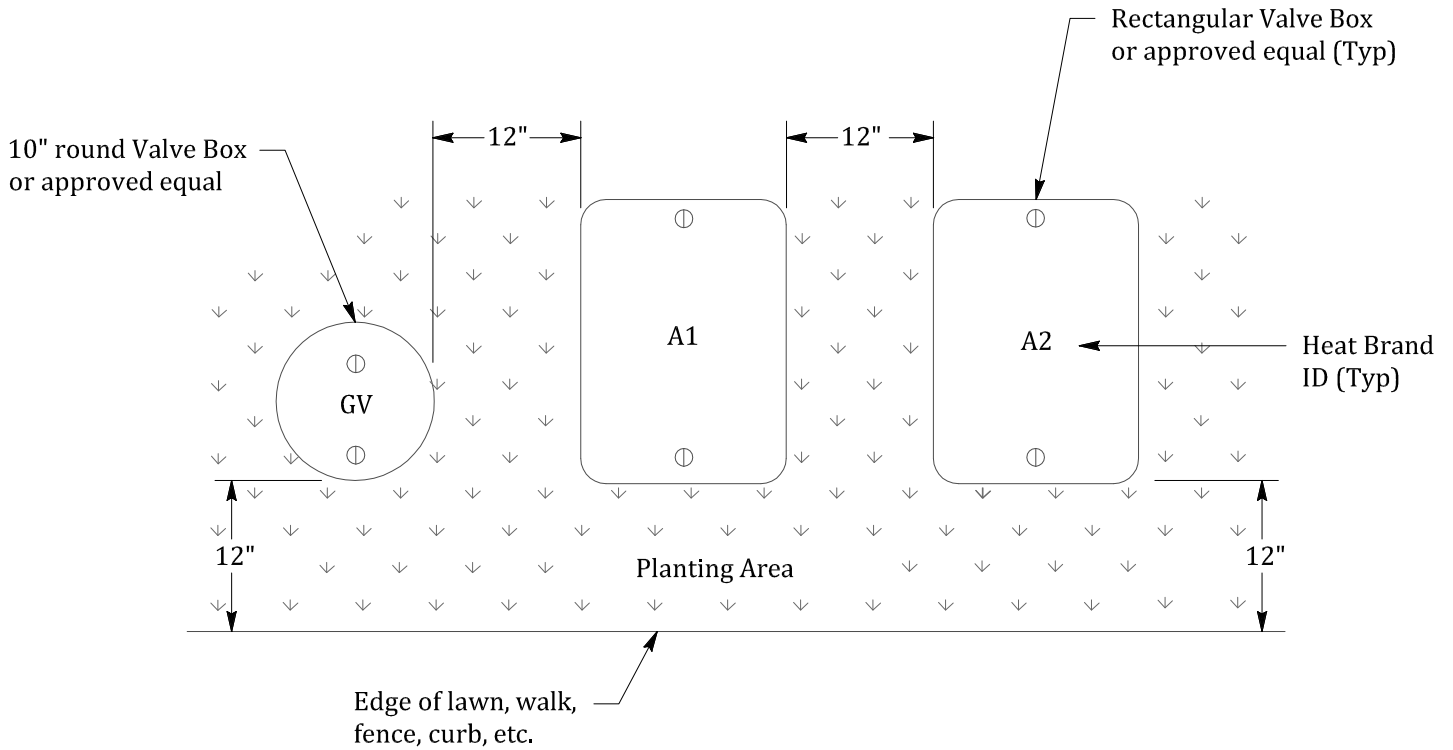

NOTES:

1. Center boxes over valves to permit service of valves and unions
2. Set boxes in ground cover/shrub area where possible
3. Set boxes parallel to each other and perpendicular to edge
4. Set boxes 1" above grade in turf areas and 3" above grade in shrub areas
5. Avoid heavily compacting soil around boxes to prevent damaging valve boxes
6. Heat Brand ID on valve box lid with 2" height letters:
 'X1' for Remote Control Valves ('X' = Controller '1' = station number)
 'FM' for Flow Meter
 'MV' for Master Control Valve
 'GV' for Gate Valve
 'QC' for Quick Coupling Valve
 'SP' for Splice Box or Pull Box
7. Install Stainless Steel bolts in locking cover.
8. When non-potable water is used, boxes and lids shall be color-coded purple
9. For all valves 1 1/2" and larger, jumbo box shall be used
10. Install valve box extensions as required to completely enclose valve assemblies
11. Cover box cut-outs to prevent soil in box

NOT TO SCALE

APPROVED BY		DATE		IRRIGATION VALVE BOX INSTALLATION	STD. PLAN NO.
		JUNE 2016			IR-08
CITY ENGINEER					

STEP 1: Strip wires 1/2" from ends.

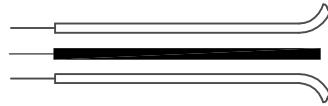

STEP 2: Apply Scotchlok or approved equal Y spring connector in a clockwise direction (for clocks only)

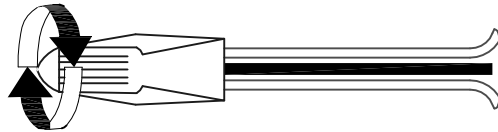

STEP 3: Insert splice to bottom of gel-filled tube. Check to make sure connector has been pushed past locking fingers and is seated at bottom of tube.

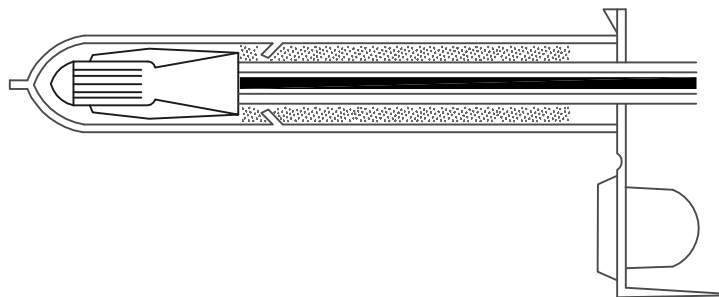

STEP 4: Position wires in wires channels and close insulator tube cover.

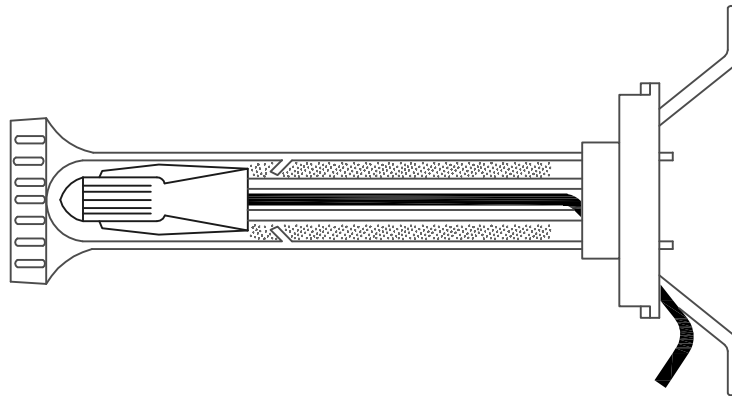

NOTE:

1. Maximum wire sizes per connector are 3-#4's or 2-#12's
2. Use 3M DBR/Y-6 Direct Bury Splice Kit or approved equal

NOT TO SCALE

APPROVED BY	DATE		IRRIGATION WIRE CONNECTION	STD. PLAN NO.
 CITY ENGINEER	JUNE 2016			IR-09

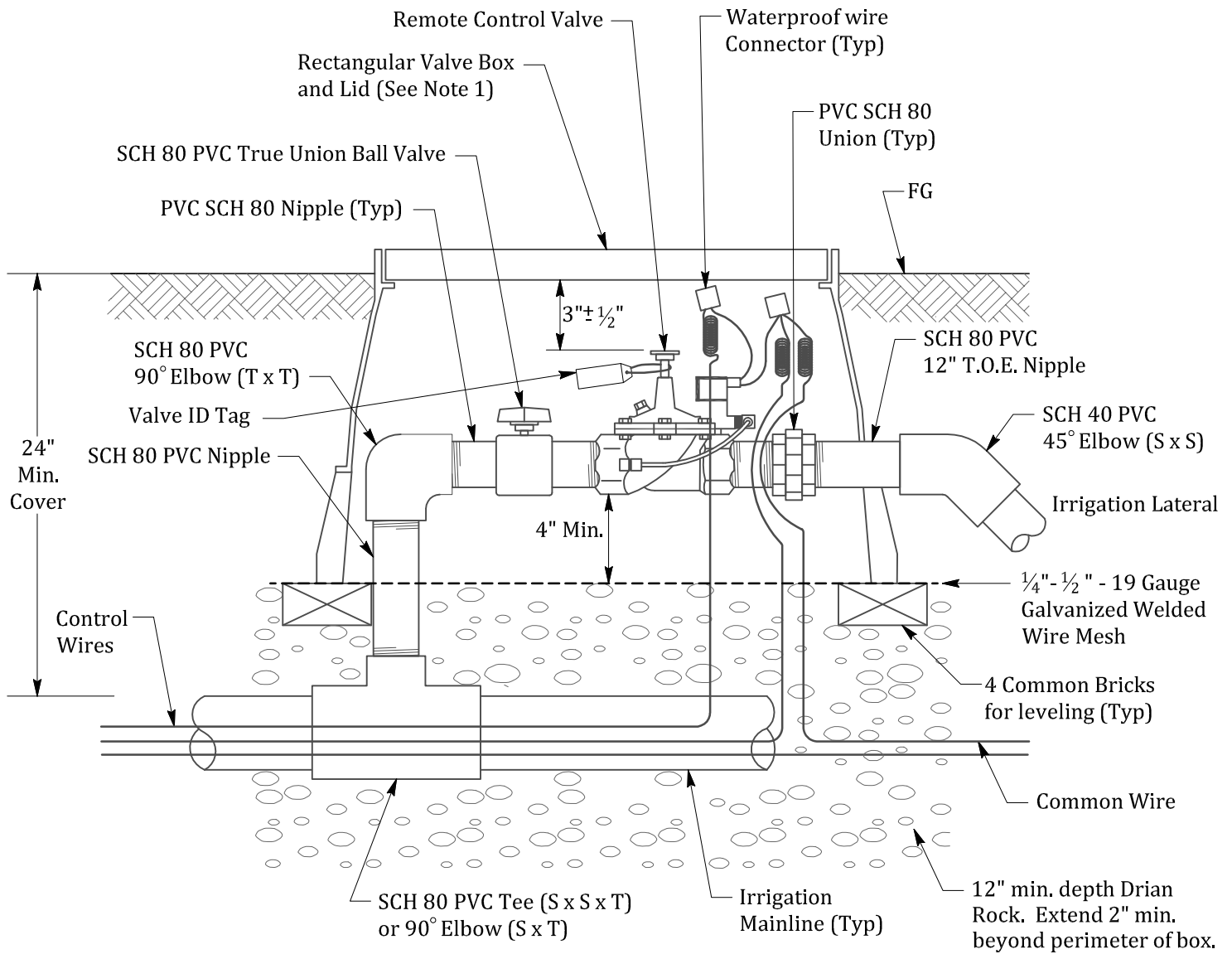

PLAN

NOTES:

1. See Standard Plan IR-08 for Irrigation Valve Box Installation
2. Valve ID Tags shall be attached to the remote control valve with the controller and station number
3. When used with non-potable water, designate purple color-coding on appropriate appurtenance.
4. All low voltage wires shall be 14 gauge for control and 12 gauge for common. Common wires shall be white with a colored strip. Stripe color shall be different for each controller installed. Control wires shall be of one color other than white or green. A different color control wire shall be used for each controller installed.

NOT TO SCALE

APPROVED BY	DATE		<h2 style="margin: 0;">REMOTE CONTROL VALVE</h2>	STD. PLAN NO.
 CITY ENGINEER	JUNE 2016			IR-10

* or approved equal

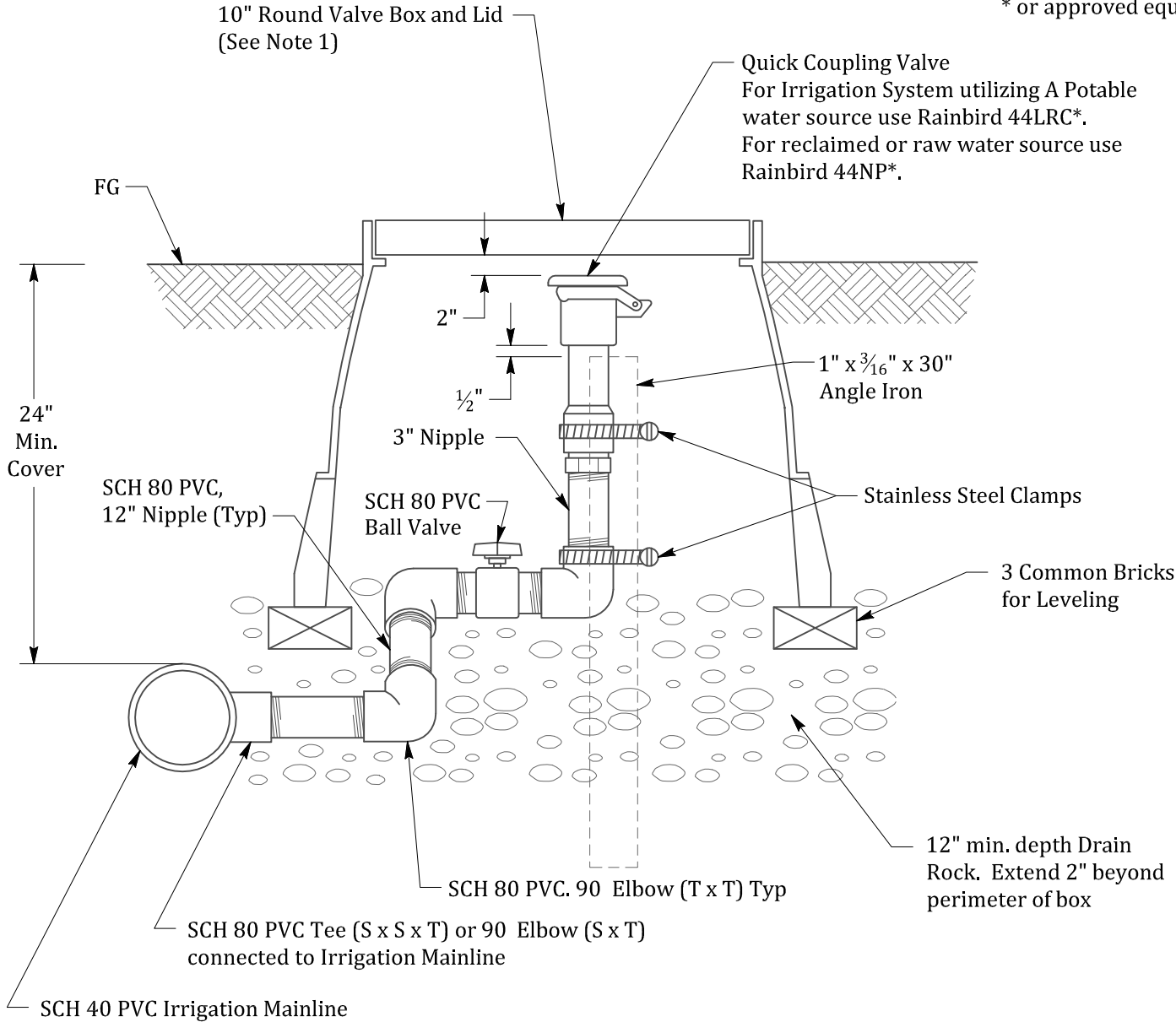

PLAN

NOTES:

- 1. See Standard Plan IR-08 for irrigation Valve Box Installation
- 2. When used with reclaimed water, designate purple color-coding on appropriate appurtenance.

NOT TO SCALE

APPROVED BY	DATE		<p>QUICK COUPLING VALVE</p>	STD. PLAN NO.
	JUNE 2016			IR-11
CITY ENGINEER				

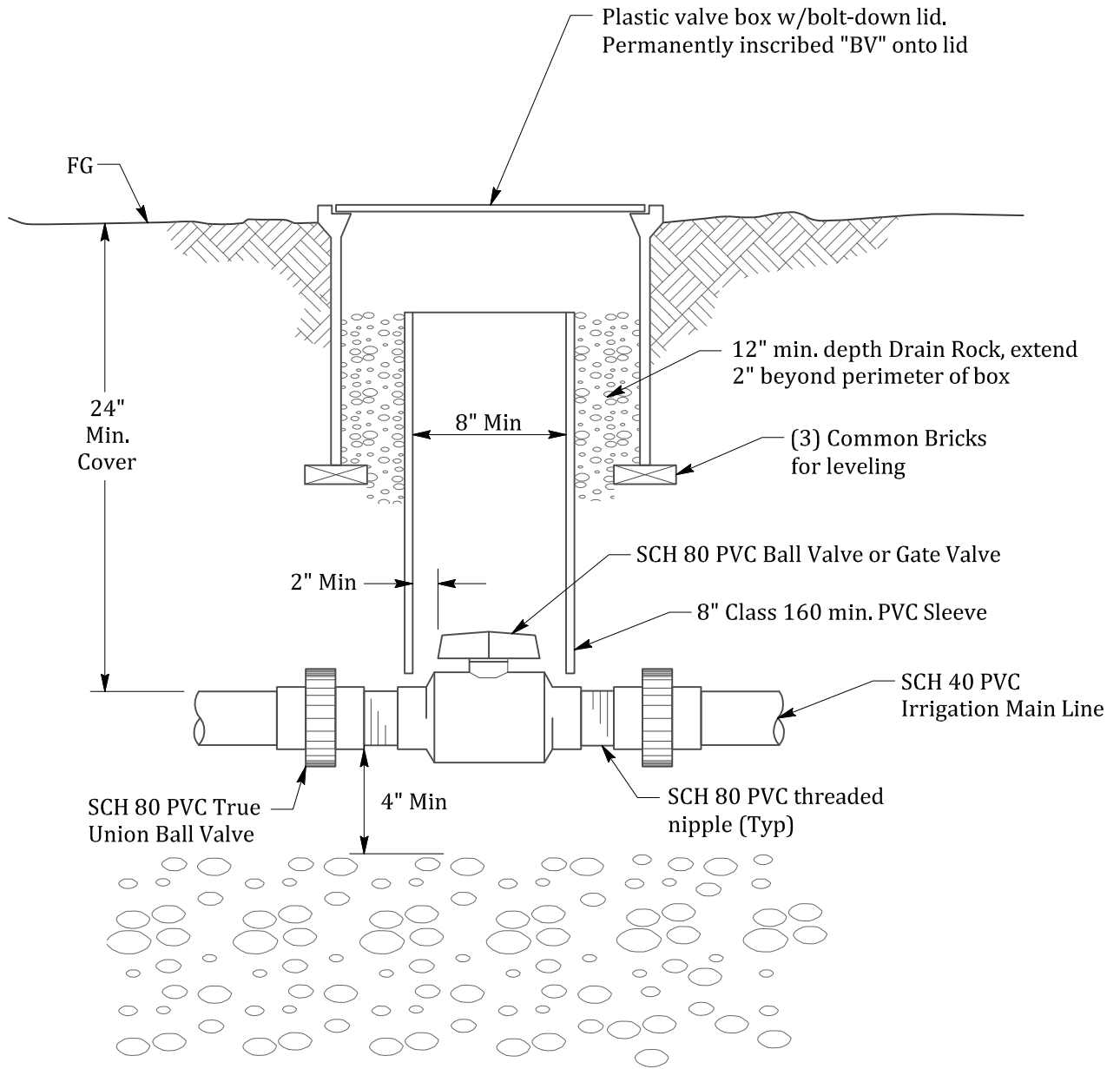

PLAN

NOTES:

1. See Standard Plan IR-08 for irrigation Valve Box Installation
2. When used with reclaimed water, designate purple color-coding on appropriate appurtenance.

NOT TO SCALE

APPROVED BY	DATE		GATE/BALL VALVE	STD. PLAN NO.
	JUNE 2016			IR-12
CITY ENGINEER				

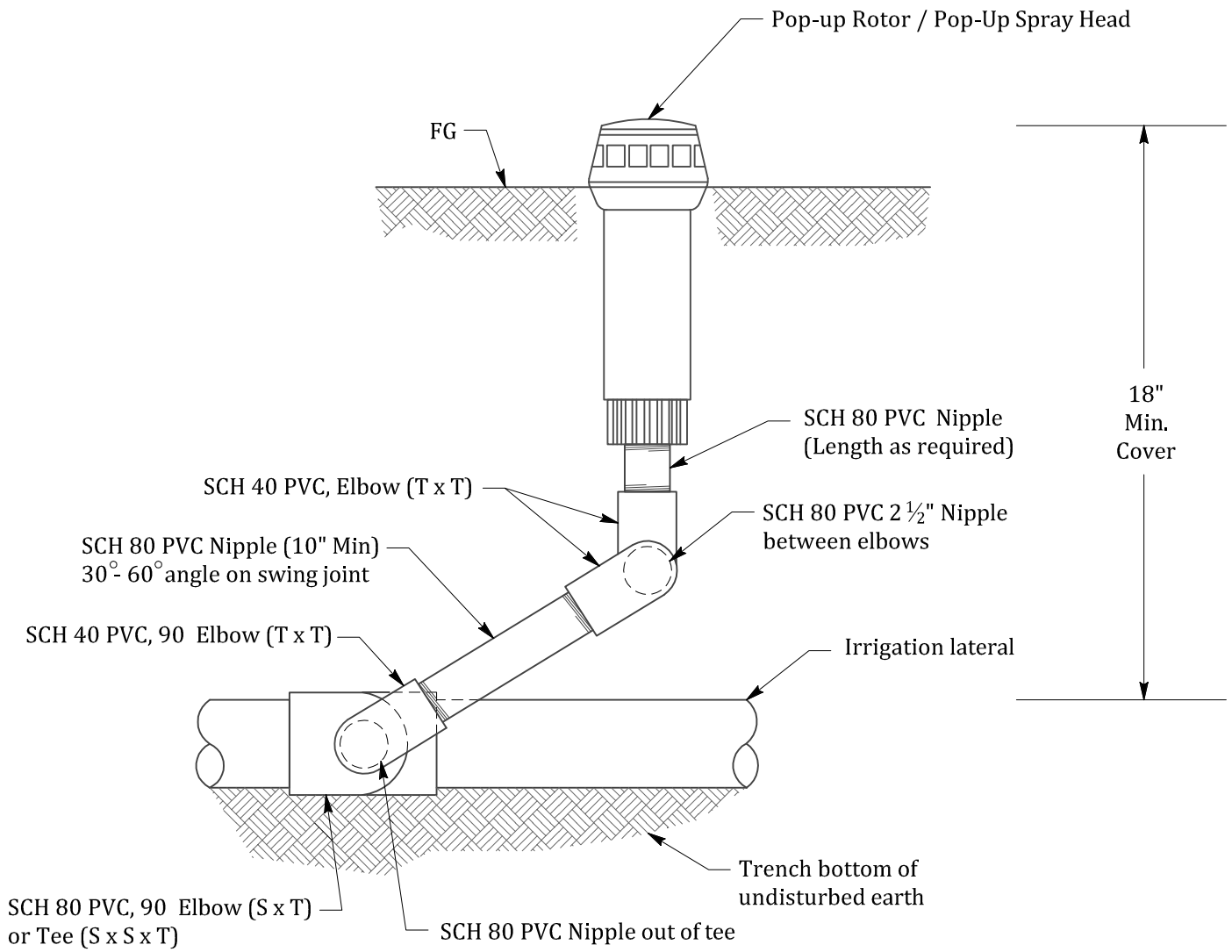

NOTES:

1. Set head 1" above grade in turf areas and 3" above grade in shrub areas

NOT TO SCALE

APPROVED BY	DATE		ROTOR AND POP-UP SPRAY HEAD	STD. PLAN NO.
<i>Kevin Rohani</i>	JUNE 2016			IR-13
CITY ENGINEER				

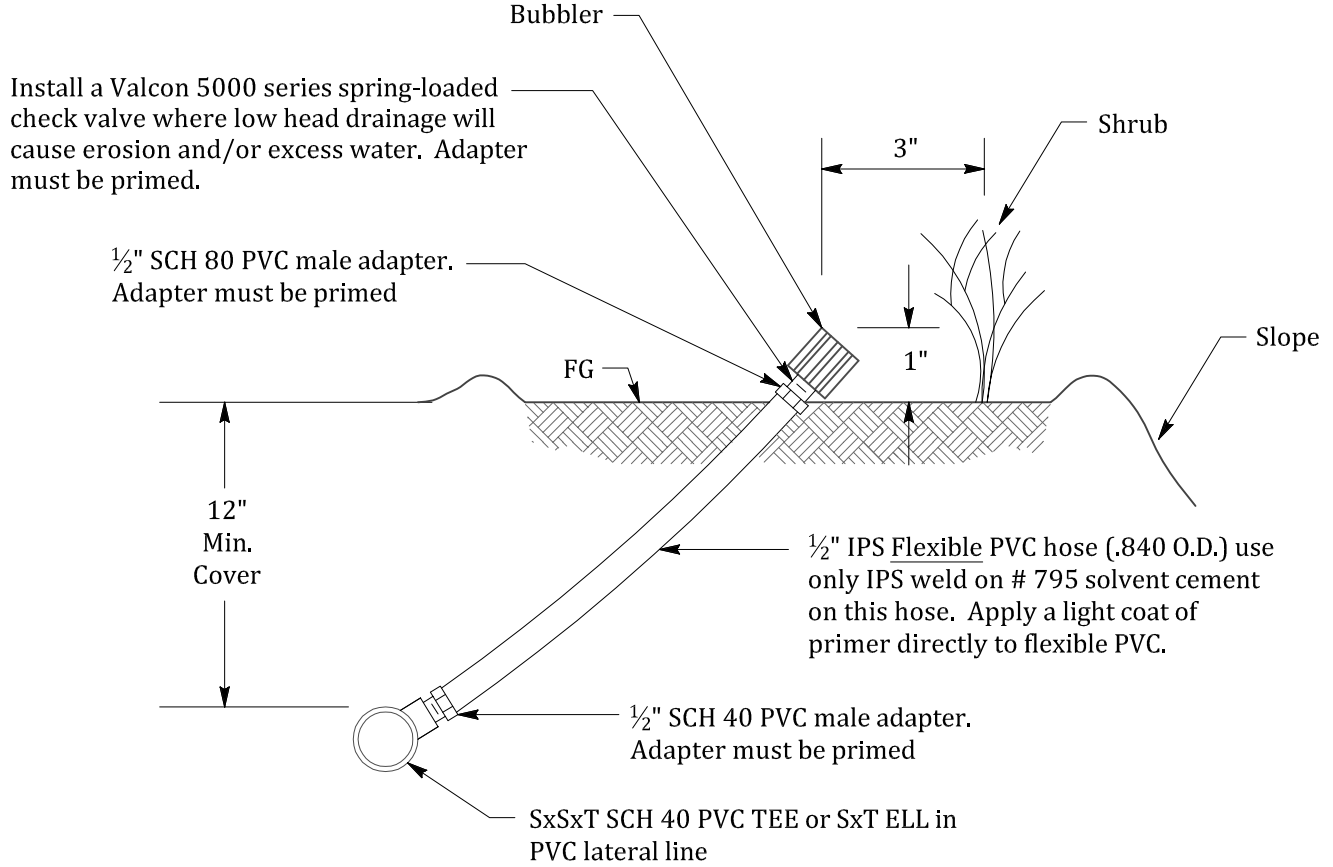

PLAN

NOT TO SCALE

APPROVED BY	DATE		SHRUB BUBBLER AND FLEXIBLE RISER	STD. PLAN NO.
 CITY ENGINEER	JUNE 2016			IR-14

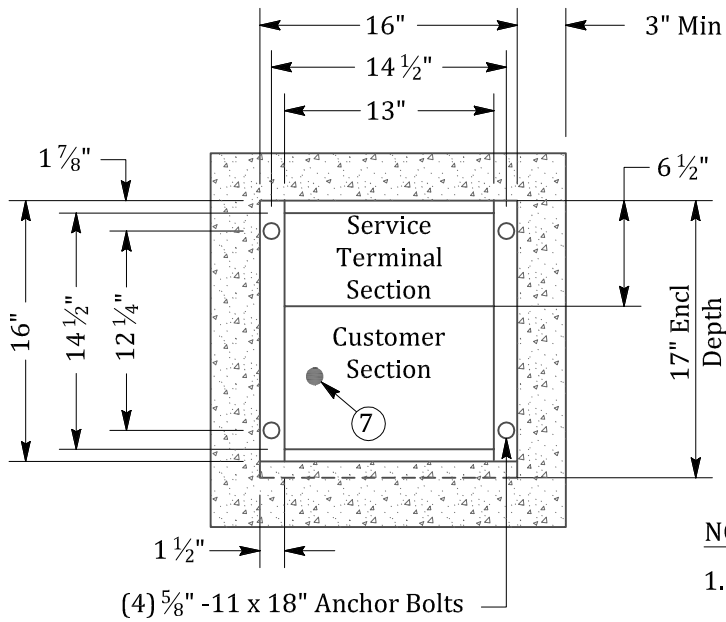

MOUNTING BASE

LEGEND:

- ① Means provided to hold door in open position
- ② Demand meter reset cover with window
- ③ Padlock Bracket extending thru door for security
- ④ Lift off Service Cover
- ⑤ Hinged Deadfront
- ⑥ Fully hinged meter/test section cover
- ⑦ Ground Rod

NOTES:

- 1. Landscape screening shall be required with 36" Min clearance on the front and back of the enclosure.
- 2. Service Cabinet shall be type Milbank West CP3B1115A Stainless Steel for 100-Ampere and less or approved equal.

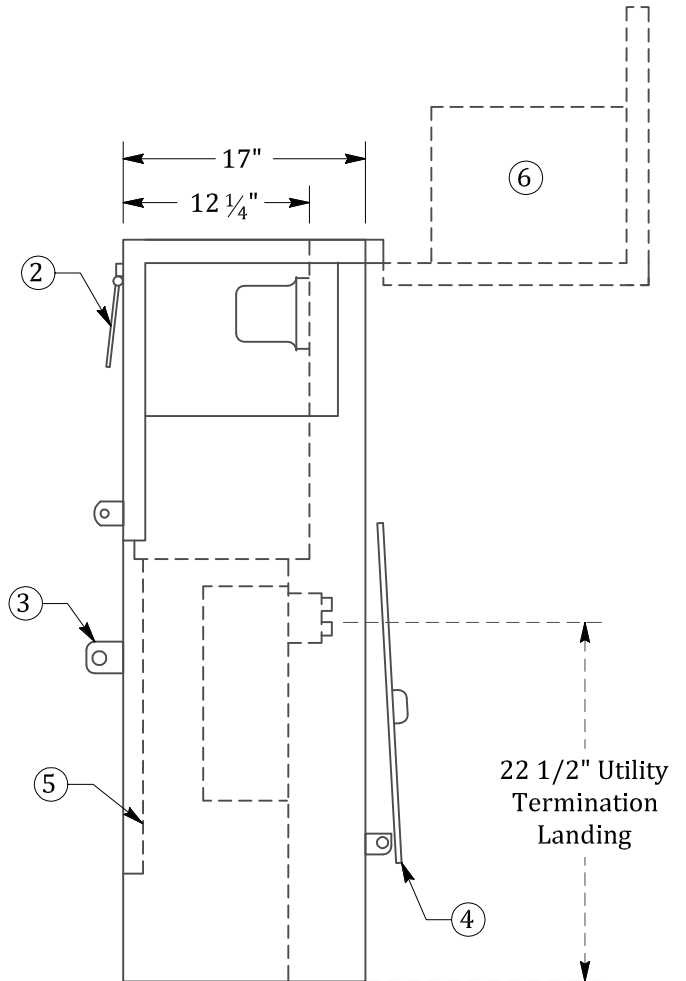
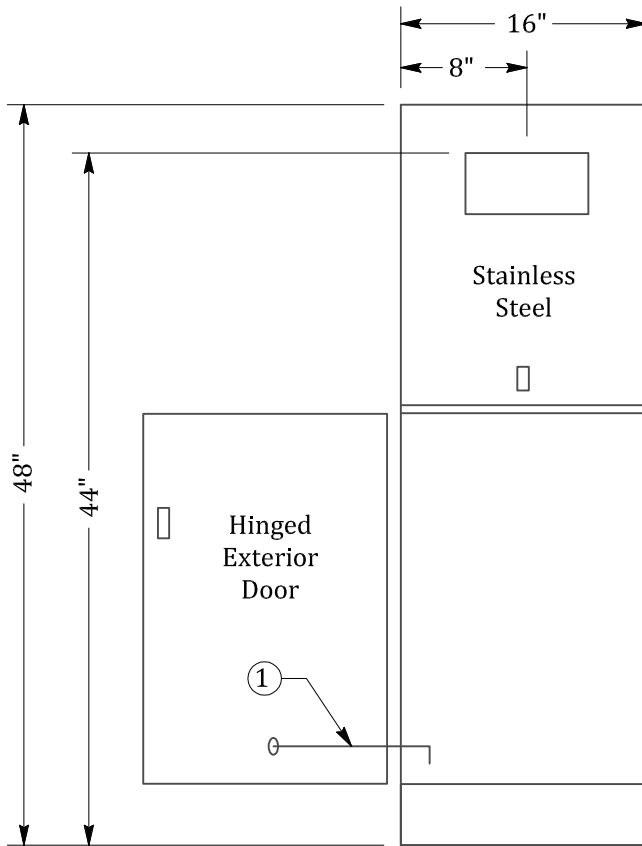

CABINET SECTION

NOT TO SCALE

APPROVED BY	DATE		IRRIGATION ELECTRIC METER PEDESTAL	STD. PLAN NO.
 CITY ENGINEER	JUNE 2016			IR-15

PARK FURNISHINGS

ITEM	MANUFACTURER/MODEL OR APPROVED EQUAL	NOTES
PARK BENCH	DUMOR, Inc. MODEL: 119-60 (6' and 8')	Vertical Slat w/back, Non-skateboard, Black, Middle arm rest
PICNIC TABLE	OUTDOOR CREATIONS Inc. SIDE ENTRANCE TABLE, MODEL:100S and 100SLE or 100SRE	Table color: Davis Sequoia Sand 11" x 5.2" New City of Oakley Logo in full relief on legs of table (2), no color
INDIVIDUAL BARBEQUE - METAL	PILOT ROCK, MODEL: B24/8 B2	
FAMILY BARBEQUE - CONCRETE	OUTDOOR CREATIONS, Inc. CONCRETE FAMILY BARBEQUE MODEL: 300A	Barbeque color: Davis Sequoia Sand 11" x 5.2" New City of Oakley logo in full relief on opposing sides (2) of receptacle, no color
DRINKING FOUNTAIN	HAWS BARRIER FREE STAINLESS STEEL PEDESTAL FOUNTAIN MODEL: 3500D-FR	Vandal resistant, green powder coated finish with pet fountain, use Freeze Resistant Bury Valve as specified by the City of Oakley
TRASH RECEPTACLE	OUTDOOR CREATIONS Inc. CONCRETE TRASH RECEPTACLE - ROUND MODEL: 500	Trash Receptacle color: Davis Sequoia Sand 16" x 6" New City of Oakley Logo engraved and painted as specified on 1 side of trash can
RECYCLE RECEPTACLE	DUMOR, Inc. RECEPTACLE DWG NO. 360-0127-32-RC0075 SH1	Receptacle color: Blue
DOG WASTE DISPENSER	ZERO WASTE, MODEL JJ13008	
BLEACHERS	MIRACLE RECREATION EQUIPMENT GALANIZED STEEL MODEL: 98936 ALUMINUM MODEL: 98931	3 Rows x 15'

APPROVED BY	DATE		PARK FURNISHINGS	STD. PLAN NO.
	JUNE 2016			M-01
CITY ENGINEER				

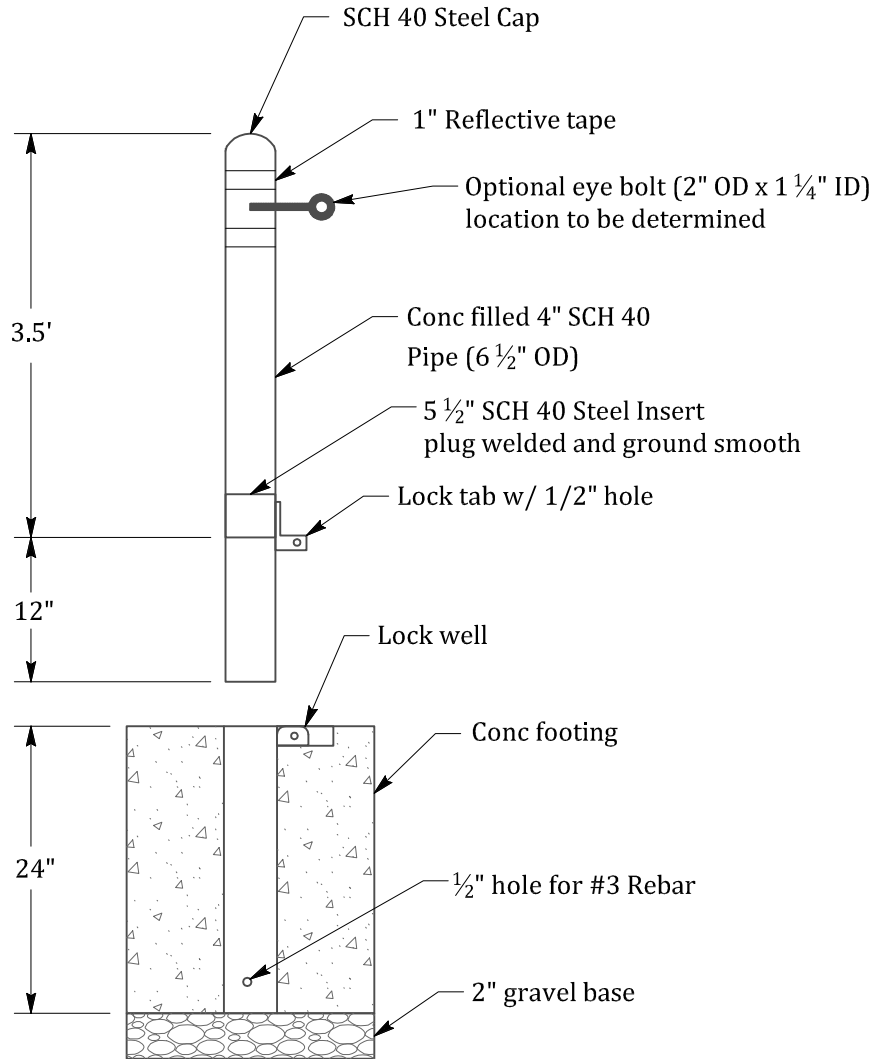

NOTES:

1. Add reflective tape , two 1" bands at top
2. Use manufactured product such as Patterson-Williams (i.e. Model 1100-04-LK removable metal bollard)

NOT TO SCALE

APPROVED BY	DATE		REMOVABLE BOLLARD PARK OR TRAIL	STD. PLAN NO.
 CITY ENGINEER	JUNE 2016			M-02

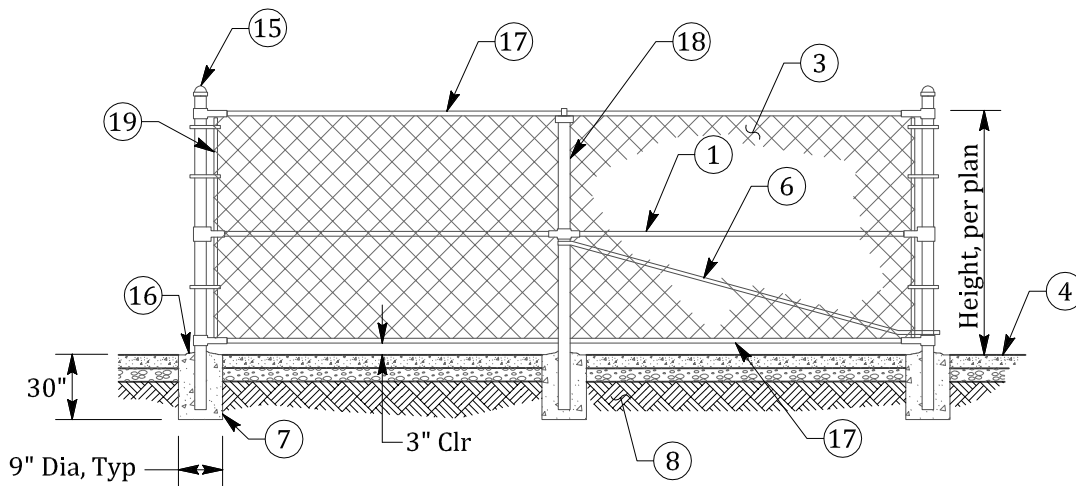

CHAIN LINK FENCE

NOTES:

- A. Concrete for footings shall be Class "B" (2500 PSI) for more information, see Specifications.
- B. Provide Submittal for all materials.
- C. 36" depth for 4' high fence, 48" depth for 6' high fence and above.
- D. 12" diameter for 4' high fence, 18" diameter for 6' high fence and above.

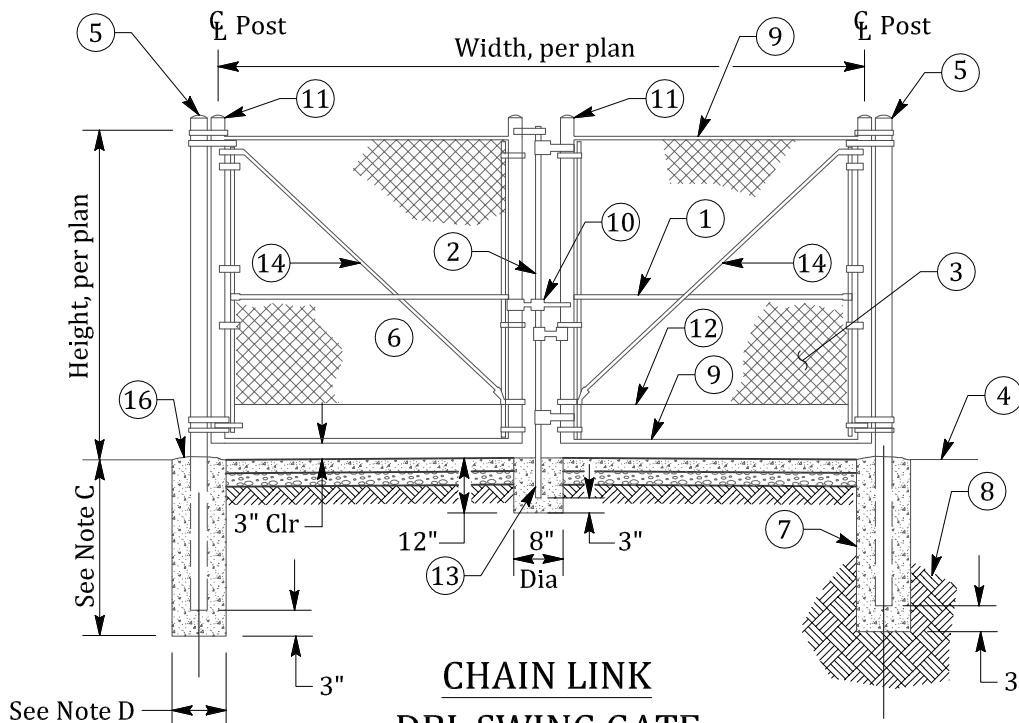

CHAIN LINK DBL SWING GATE

LEGEND:

- ① Midrail 1 5/8" diameter for Gates 6' high minimum
- ② Locking Mechanism
- ③ Chain Link wire Mesh and Posts, Galv. & Powder Coated: Black
- ④ Finish Grade, or Finish Surface
- ⑤ Terminal or Corner Post at Gate, 3" diameter
- ⑥ Truss Rod, at corners and ends
- ⑦ Post Concrete Footing, typical
- ⑧ Compacted subgrade to 95% Relative Compaction.
- ⑨ Gate Rail, 1 7/8" outside diameter
- ⑩ Gate Lock, NIC to be determined by owner.
- ⑪ Gate Frame vertical, 2 1/2" O.D. for 4' high fence, 3" O.D. for greater than 4' high fence.
- ⑫ Gate Bottom, per specifications.
- ⑬ Concrete footing w/sleeve to accept locking mechanism in closed position, typical of 2 (other location to be where gate is open, VIF)
- ⑭ Tension or Tensil, not compression.
- ⑮ Corner Post, 2 1/2" diameter, for corner post see 5 .
- ⑯ Slope away from post.
- ⑰ Top & Bottom Rail, 1 5/8" diameter pipe.
- ⑱ Line Post, 2 1/4" diameter pipe.
- ⑲ Stretcher Bar, typical

NOT TO SCALE

APPROVED BY	DATE		FENCE CHAIN LINK	STD. PLAN NO.
 CITY ENGINEER	JUNE 2016			M-03

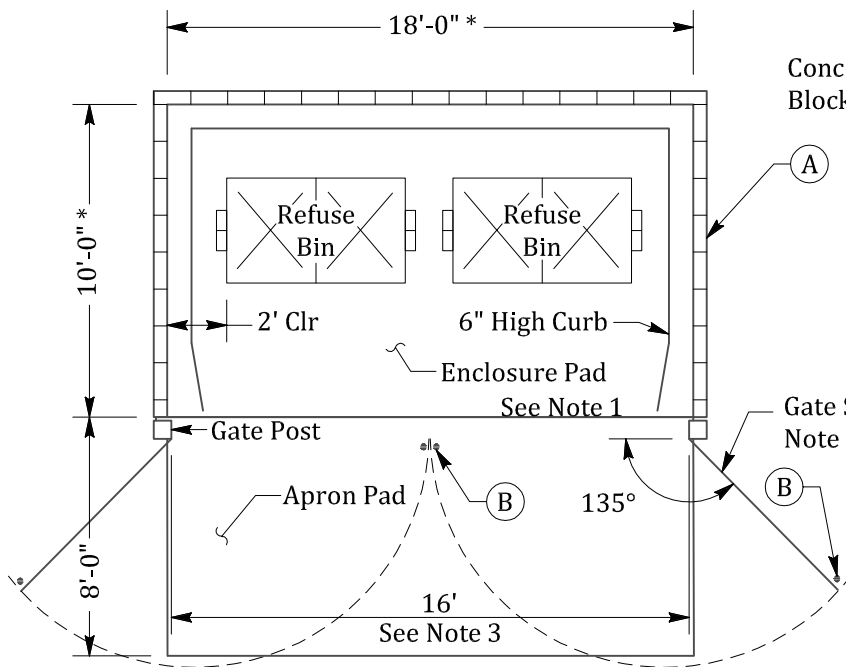

TOP VIEW

* Inside Dimension

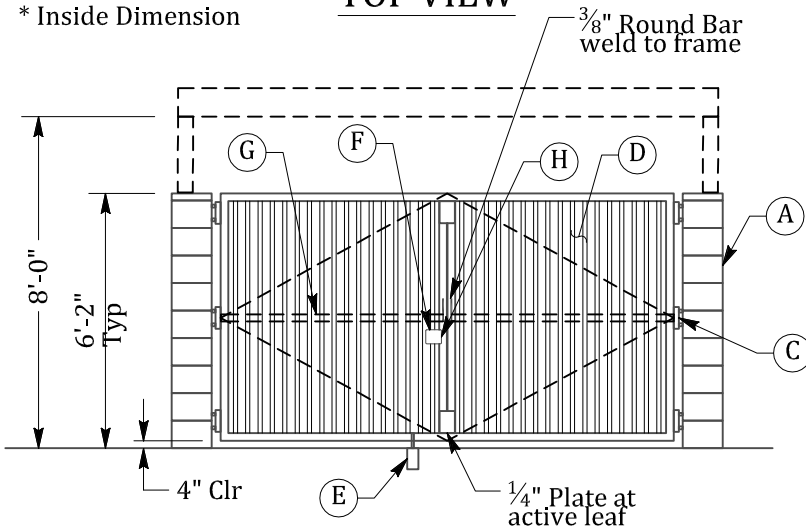

FRONT ELEVATION

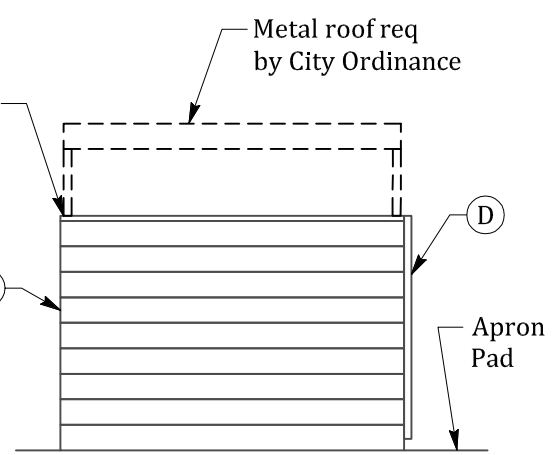

SIDE ELEVATION

LEGEND:

- (A) Concrete Block or Reinforced Masonry Block shall be split face or decorative or the masonry be painted or plastered to match the main building.
- (B) Receiving sleeve. Outside location 135° Min angle from closed gate position.
- (C) Stanley, or approved equal. Heavy duty surface mounted external hinges, weld to metal angle
- (D) ASC Pacific "HR-36" 18 GA G.I. Mtl Panels, or approved equal-Paint over shop prime.
- (E) Ideal 64-6813 or approved equal. Cane bolt & keeper interior.
- (F) King Arch. Metals 30-100 Weldable slide bolt latch or approved equal.
- (G) 1-1/2" Square Steel Tube weld to frame at interior, Typical.
- (H) 4" Sq. x 1/4" Plate Butt Weld w/rounded corners for bolt latch.

NOTES:

1. Pad shall be Engineered to withstand 20,000 lbs of direct force from a single truck axle.
2. A minimum of 32' Vert. and 50' Horiz. clearance over the entire approach to and from the enclosure shall be provided.
3. Gates shall be solid metal with cane bolts sleeves in the open and closed position. Each gate, with a minimum total span width of 16' shall swing open a Min of 135° from closed position. Hung gates have a 4" Clearance off the finished pad or apron and surrounding curb.
4. The trash enclosure pad shall be designed to drain to a sewer connection as approved by the City of Oakley. A water connection may be required by the Contra Costa County Health Department.
5. The enclosure exterior shall comply with standard conditions of approval for commercial and industrial projects. No enclosure shall be installed behind parking spaces.
6. ONLY solid waste containers and recycle containers are allowed inside the enclosure. Grease storage bins, soiled rag storage, etc. shall never be stored in the enclosure.
7. Roof and gates shall be powder coated and match in color.

NOT TO SCALE

APPROVED BY	DATE		SOLID WASTE TRASH ENCLOSURE	STD. PLAN NO.
 CITY ENGINEER	JUNE 2016			M-04